

Perforation pattern: Globe G1 (Ø6mm hole cc 15mm)
 Perforation procentage: 10,2 %
 Edge type: Contur D
 Grid: S24
 Module: 600 x 600 x 12,5mm
 Visible measure (primary): 600 x 600mm
 External measure (secondary): 600 x 600mm
 A measure: 37,5mm
 Perforation picture: 525 x 525mm (36 x 36 holes)

Project: Contur D, S24, Module 600x600, G1	MDM no.: 24799
Subject:	Scale:
KNAUF DANOLINE	Date: 2018-06-04
	Rev.:
	Sign.: NPJ
	Project no.:
Knauf Danoline A/S Kløvermarksvej 6, DK-9500 Hobro T: +45 9657 3000 F: +45 9657 3001 www.knaufdanoline.com - info@knaufdanoline.com	File:

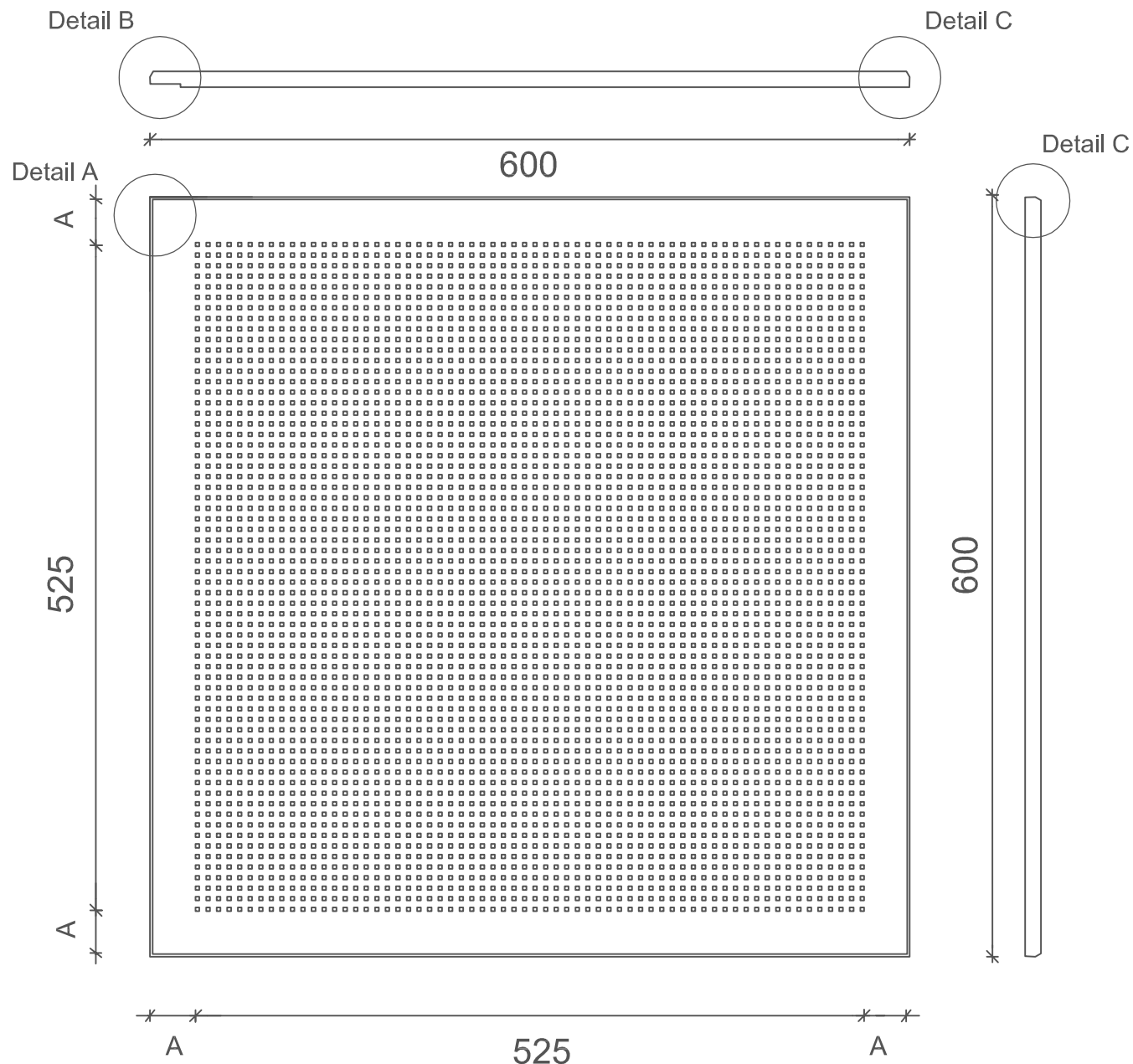

Detail A

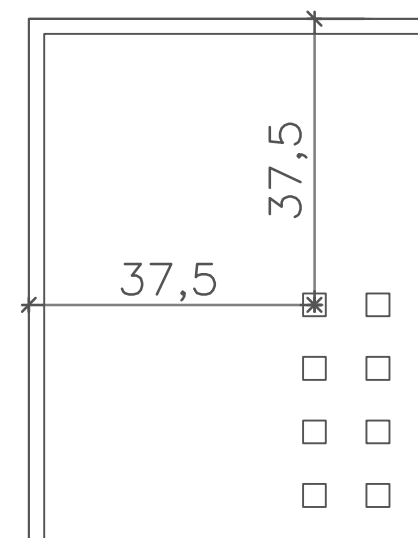

Detail B

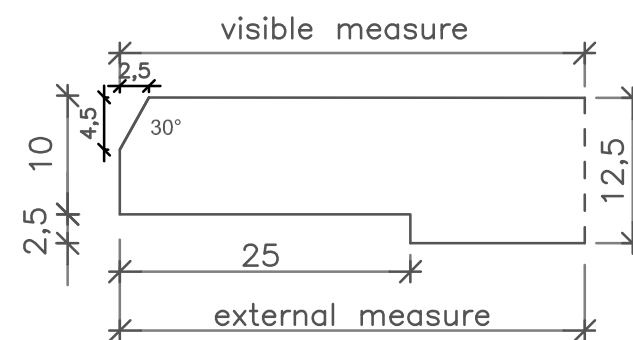

Detail C

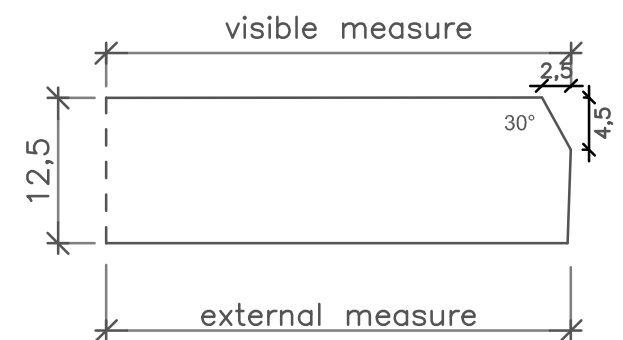

Perforation pattern: Micro M1 (3x3mm holes cc 8,3mm)
 Perforation procentage: 10,2 %
 Edge type: Contur D
 Grid: S24
 Module: 600 x 600 x 12,5mm
 Visible measure (primary): 600 x 600mm
 External measure (secondary): 600 x 600mm
 A measure: 37,5mm
 Perforation picture: 525 x 525mm (64 x 64 holes)

Project: Contur D, S24, Module 600x600, M1

Subject:

MDM no.:

54460

Scale:

Date: 2018-06-04

Rev.:

Sign.: NPJ

Project no.:

File:

KNAUF DANOLINE

Knauf Danoline A/S Kløvermarksvej 6, DK-9500 Hobro
 T: +45 9657 3000 F: +45 9657 3001
 www.knaufdanoline.com - Info@knaufdanoline.com

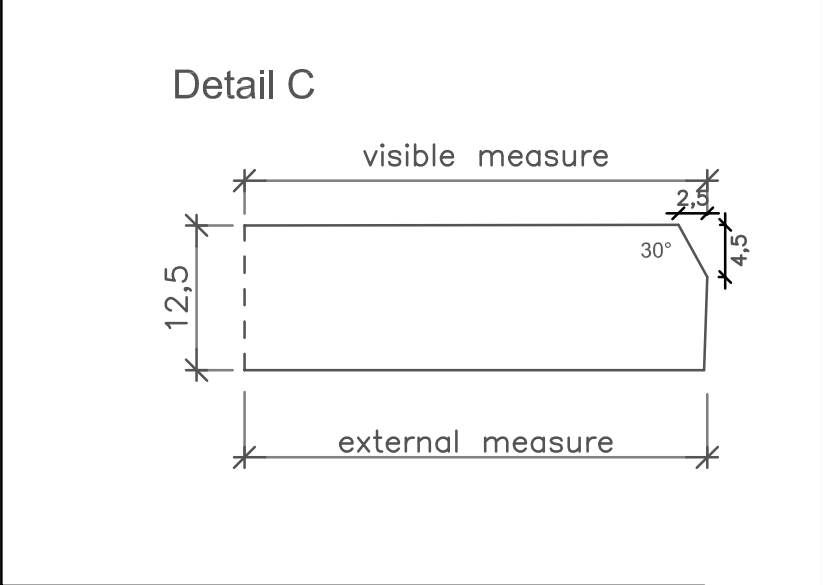
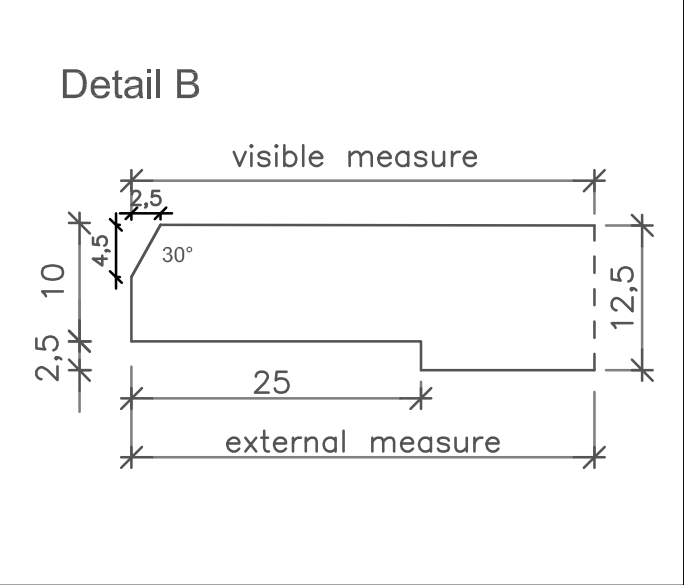
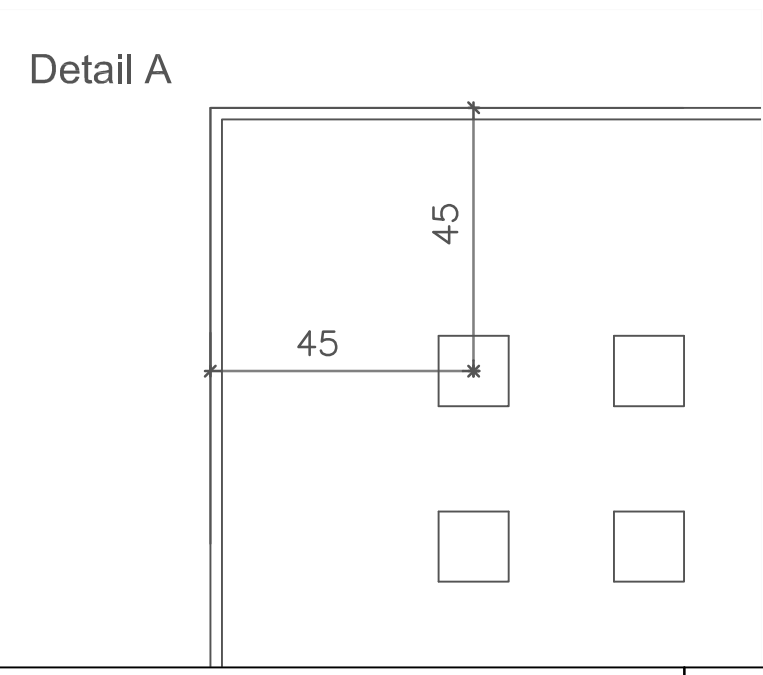
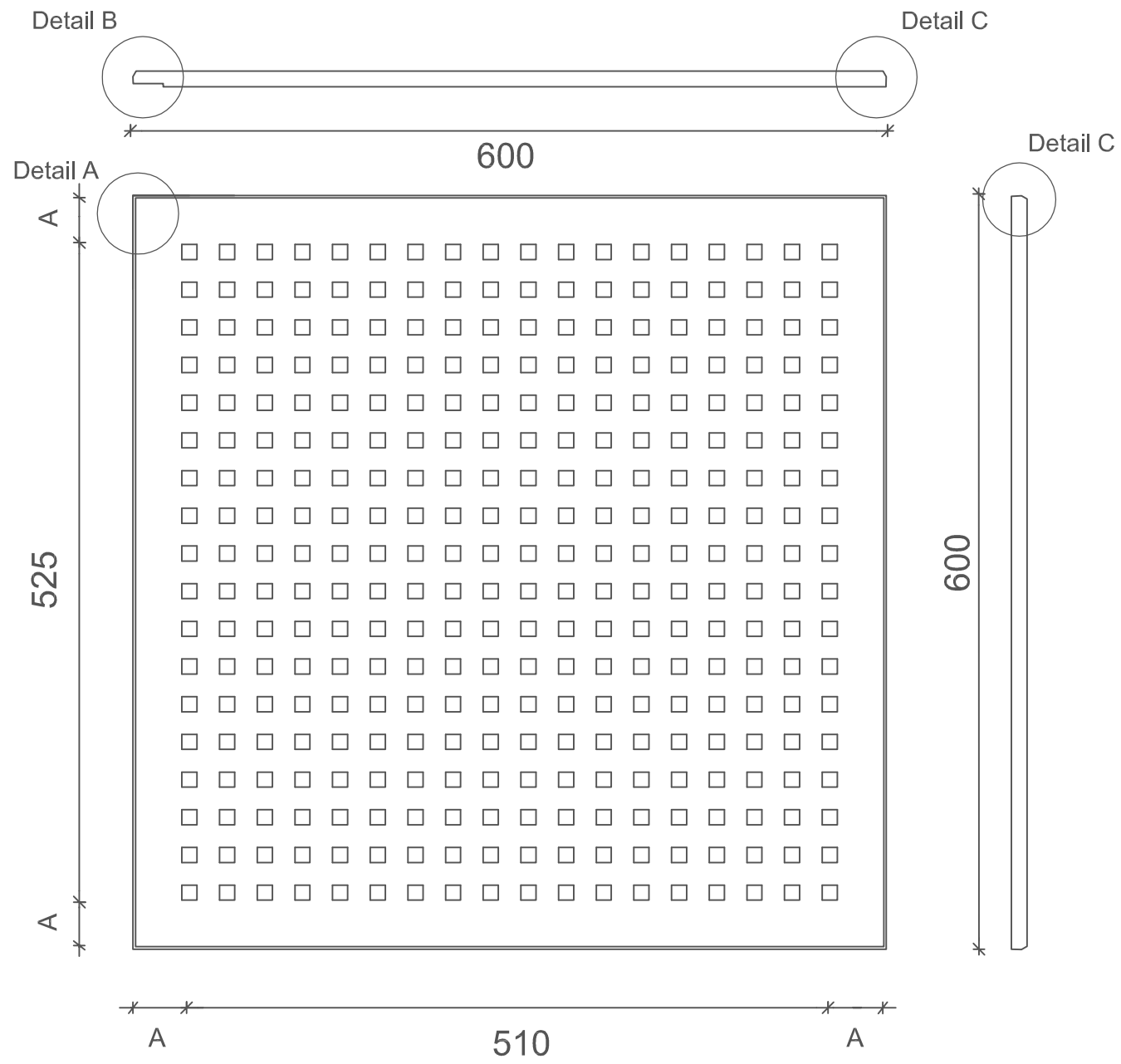

Perforation pattern: Quadril Q1 (12x12mm holes cc 30mm)
 Perforation procentage: 13 %
 Edge type: Contur D
 Grid: S24
 Module: 600 x 600 x 12,5mm
 Visible measure (primary): 600 x 600mm
 External measure (secondary): 600 x 600mm
 A measure: 45mm
 Perforation picture: 510 x 510mm (18 x 18 holes)

Project: Contur D, S24, Module 600x600, Q1	MDM no.: 24804
Subject:	Scale:
	Date: 2018-06-04
	Rev.:
	Sign.: NPJ
	Project no.:
Knauf Danoline A/S Kløvermarksvej 6, DK-9500 Hobro T: +45 9657 3000 F: +45 9657 3001 www.knaufdanoline.com - info@knaufdanoline.com	File: