

KNAUF

November 2025

Knauf Drywall Systems Performance Guide

*To support both EN (European)
and BS (British Standards)
compliance projects*

Creation Date: 03/11/2025
Revision Reference: 01
Revision Date: 03/11/2025



Build on us.

Content

BUILD ON US

03

Building a safer future	04
Data and system performance warranty	05
Supporting you throughout the project	06
Specification tools	07
A little more about us	08

KNAUF DRYWALL SYSTEMS

10

System Finder: EN or BS Compliance Systems	11
Knauf Drywall Systems	12
Table Guide	14
EN Compliance Specification Tables	15
BS Compliance Specification Tables	36
Specialist Knauf Encasement Systems	57
Deflection Heads	67

BUILD ON US.

As a global leader in construction materials, Knauf delivers high-performing systems to help build the spaces where we live, learn and care. With robust data, industry-leading technical support, and hands-on guidance, we help reduce risk, ensuring safe, compliant, and efficient builds.



Building a safer future

Following the Grenfell tragedy, the Building Safety Act (2022) introduced new regulations mandating stricter practices for all Higher-Risk Buildings, enhanced the obligations of duty holders and put a focus on competence within the industry. This represented the biggest regulatory and reformatory change to impact the construction sector in [nearly 40 years](#).

These regulations aim to enhance safety and accountability throughout the construction process, the essence of which was establishing what became known as the 'Golden Thread', whereby all designs, products and systems are tracked through the entire build process of a project, from specification through to build. Any changes made to the specification would need to be passed back up the chain of command to be approved and signed off by the original specifier and regulator.

At Knauf, we're committed to building a safer future and are strong advocates for the Golden Thread, a digital record that ensures transparency and accountability throughout a building's lifecycle. You can either specify our systems through [NBS](#) or our own [Systemfinder](#) specification tools - by using either of these you can ensure compliance with Golden Thread. Our team are also on-hand to provide guidance along the way.

It is important to note that the specific requirements and implementation of these regulations may vary across different parts of the UK and Ireland, reflecting regional governance and building control frameworks. We are well-placed to support projects across the UK and Ireland, offering expertise and tailored solutions to ensure compliance with all relevant regulations, inclusive of regional variations.

How the Golden Thread runs through construction Gateway

This innovative approach also introduces a three-stage gateway process designed to elevate fire safety standards.

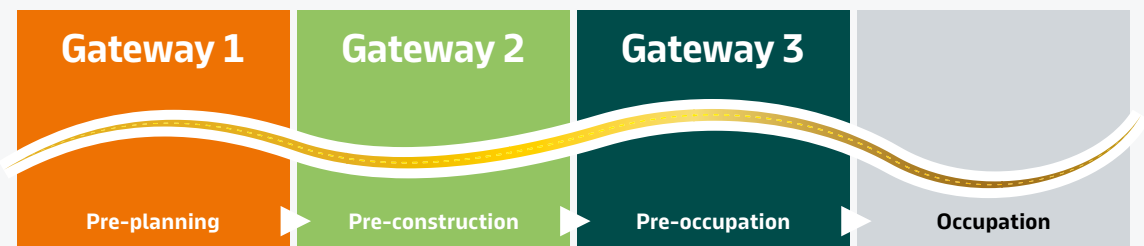

Pre-planning

This initial stage focuses on providing a fire statement for the planning phase. This statement outlines key considerations such as fire service access and water supply for firefighting purposes.

Pre-construction

This stage is about ensuring that the design of the building can demonstrate conformance to and compliance with the relevant building regulation requirements. All design changes at this stage are deemed either 'Recordable Changes', 'Notifiable Changes' or 'Major Changes'.

Pre-occupation

This final stage ensures that as-built data is readily available before the building is occupied. Furthermore, all the new buildings will require a Building Assurance Certificate issued by the Building Safety Regulator (BSR) before they can be occupied.



Data and system performance warranty

Our dedication to rigorously testing complete systems to the relevant standards guarantees confidence in their safety and performance. This commitment is reinforced by our 100% Knauf System Performance Warranty, providing you with peace of mind.

In summary, all our products and systems are robustly tested by accredited third-parties, to provide customers with comfort when using them in their design.

Find out more about our **100% Knauf System Performance Warranty**



100%
KNAUF SYSTEM

Performance Tested
and Approved

Supporting you throughout the project

Our project support is designed to support you, the design team, throughout every stage of your project, from conceptual design to onsite detailing. We start by delving deep into the architectural brief, aiming to fully understand your vision and requirements. With our extensive experience and access to leading solutions that ensure regulatory compliance we are confident in being able to support your project through every stage.

From the initial project brief, we aim to identify any challenges that could arise, ensuring compliance with relevant regulations and proactively addressing challenges. Our guidance extends beyond the initial design phase; we provide you with a comprehensive project pack that includes detailed specifications providing solutions specifically tailored for our systems. This approach not only aids in seamless project execution but also ensures that all aspects of the project align with regulatory requirements, facilitating clear pricing once contractors are involved and reducing the risk of non-compliance during construction.

Our commitment doesn't end there. We continue to offer support on site with visits and our on site tool box talks that help to ensure the finer details are understood. Our Project Technical Managers will support the on site team and contribute to aid input on design challenges as they occur. Our team thrives on introducing fresh perspectives and innovative ideas for surrounding detailing, ensuring your project benefits from the best possible solutions.

We possess a wealth of experience and knowledge that we actively share within our team. This collective experience is invaluable to architects and project design teams, making our partnership a clear advantage. With our support, you're not just getting a service provider; you're gaining a dedicated collaborator committed to helping your project succeed at every level. Choosing us means securing a reliable and competent partner in your projects today and tomorrow.

Your Project, Our Priority: Contact our dedicated support teams

Project Specification
Interior solutions expertise →

Exterior Project
Exterior solutions expertise →

Project Technical
Project compliance on-track →

Ceilings and Floorings
Dedicated expertise →





**DATA YOU CAN TRUST ON
THE PLATFORM YOU KNOW**

[View Knauf on NBS](#) →

KNAUF

SYSTEMFINDER

Your tool for efficient Knauf
systems search

[Try Systemfinder](#) →

Specification tools

At Knauf, we are committed to providing seamless support to architects and specifiers, ensuring that specifying our systems is as straightforward as possible. To that end, we offer two robust specification tools designed to cater to your varying needs.

Firstly, our key systems for High-Rise Multi Occupancy projects are integrated into NBS, streamlining the specification process for users of this platform. Within NBS, you will find not only our comprehensive range of systems but also all the necessary technical data sheets, BIM data and supporting documentation. This integration is designed to make specifying our systems straightforward and efficient, saving you valuable time and effort.

For those who prefer an alternative to NBS, we offer our own specification tool, Systemfinder. This versatile tool is available as a BIM plugin or a web app version, available from our website, providing flexibility to suit your workflow. Through Systemfinder, you can create detailed K10 specifications and easily request all the relevant product and performance data. Whether using our BIM plugin for enhanced integration with your digital models or the web app for quick access, Systemfinder ensures you have all the information you need at your fingertips.

These tools reflect our dedication to offering comprehensive support, equipping you with everything required to specify our systems with confidence and ease, regardless of your preferred method.

A little more about us

The Knauf story began with founders Karl and Alfons Knauf, whose vision set us on the path to where we are today, growing into a global industry leader, spanning 90 countries, multiple brands and more than 41,500 global employees.

Through our people and state-of-the-art plants, we produce high-performing solutions ranging from drywall systems, plasters and insulating materials all the way to external thermal insulation composite systems. Whatever your challenge, we are there with you each step of the way to help you to constantly improve how you build.

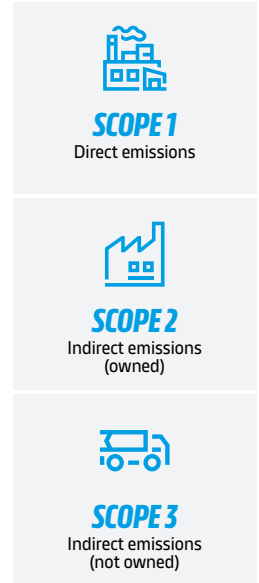
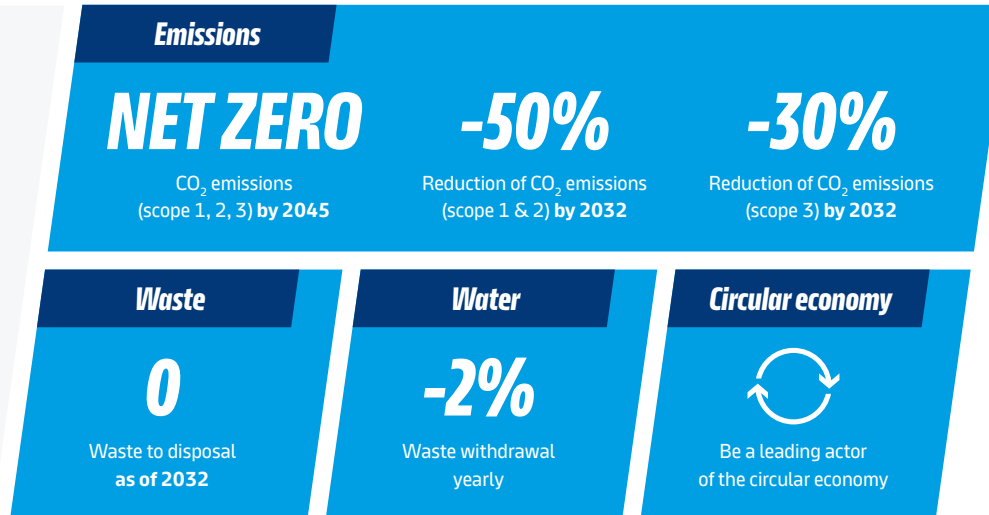

Emissions

The Knauf Group has made a commitment to reducing our emissions in Scope 1 & 2 by 50% by 2032 (coinciding with 100 years of the Knauf Group) and reducing Scope 3 emissions by 30% by 2032 with 2021 as the baseline year. We are reducing our direct and indirect emissions by:

- Investigating the use of renewable energy
- Innovating our production processes
- Working in partnership with our suppliers on emission reduction, such as with our logistics partners

By reducing the emissions in the products and services we provide you, we can help towards meeting your Scope 3 targets.

Waste

Our target on waste reduction is an ambitious goal of zero waste to disposal, which includes both landfill and incineration, by 2032.

- We are working to the waste hierarchy in our factories
- We work with a social enterprise to give alternative end of life options to products
- We offer a Plasterboard Takeback service for our customers
- We offer a bespoke plasterboard service tailored to your project, to help you to design out waste
- We use recycled content in our plasterboard production*

Water

Water scarcity is an increasing global problem due to climate change, with 2.3 billion people living in water-stressed countries according to the United Nations.**

We use water in the manufacturing of our plasterboard, and our goal is to reduce our water withdrawals by 2% annually.

- We are investing in our production processes to reduce water demand
- We continually optimise our recipes to reduce water demand

* 12.64%, 2024 average by mass for all UK produced plasterboards, recycled gypsum & paper ** Water Scarcity | UN-Water (unwater.org)

BREEAM credit reference and Knauf solutions

We can help towards achieving BREEAM on projects, with a range of products, systems and services which can help achieve credits.

- Indoor Air Quality – Some of our products have certified low emissions.
- Acoustic performance – Our acoustic ceilings and some partition systems can offer an enhanced acoustic performance.
- Environmental Product Declarations – Most of our products have externally verified Environmental Product Declarations (EPDs).
- Responsible sourcing – Our UK plasterboard production sites have held BES 6001 'Excellent' certification for over 10 consecutive years, highlighting our continued efforts in responsible sourcing.
- Severe Duty Rating – Some of our systems are rated 'Severe Duty' as per BS 5234:2 for use in corridor walls.

Take Back Scheme

The Knauf Plasterboard Take Back Scheme helps contractors reduce their waste to disposal while tracking emissions to help you achieve your goals and reduce your environmental impact.

In partnership with Encore Environment, a B-corp social enterprise, we can work with you to provide a total waste management service, from takeback on site, to BREEAM compliant reporting as standard, working to the waste hierarchy and minimising waste to landfill. Waste and emission reports are sent, and Knauf can work with you to design out waste from the outset while continuously monitoring and improving.

Knauf's Plasterboard Take Back Scheme's added initiatives such as Project Divert helps responsible main contractors win tenders through demonstrating increased social value.

Project Divert can stop waste going to landfill, reduce emissions, and save up to 30% on waste costs, while achieving social value. Following the waste hierarchy, reusable materials may be diverted to local community groups in need, with options from cost and carbon calculated to allow informed decisions to be made.

Waste Wise Kids also offers resources to use in schools, to educate children on recycling. Partner packs are available for your teams to use with local primary schools as part of the additional service, which contributes to your social value.



To find out more and register your high-rise residential site, visit our **Plasterboard Take Back Scheme**



KNAUF DRYWALL SYSTEMS

Design solutions guide

- System Finder:
EN or BS Compliance Systems
- Knauf Drywall Systems
- Table Guide
- EN Compliance Specification Tables
- BS Compliance Specifications Tables
- Specialist Knauf Encasement Systems
- Deflection Heads



System Finder: EN (European Standard) or BS (British Standard) compliance

Fire Testing Methodology: BS EN 1363-1 and BS 476-20

- Knauf drywall systems* that are required to achieve a fire resistance performance are tested in accordance with BS EN 1363-1 and BS EN 1364-1. These are the up to date and most rigorous test methodology standards to follow.
- Determining the maximum height of a drywall systems as per the BS EN 1363-1 fire test methodology, is restricted by the test furnace height, predominate test furnace heights are typically 3 metres.
- To understand the true maximum height of non-loadbearing drywall systems whilst under fire test conditions, known as 'fire state height' there are three recognised approaches:
 1. Test to furnace heights.
 2. Extended Field of Application as outlined in BS EN 15254-3 (it is important to note this standard is specific to only single metal frame, symmetrical drywall systems only).
 3. Use of Direct Field of Application as outlined in BS EN 1364-1. Adoption of such standards can support construction projects where EN compliance is required.
- BS 476-20 is an alternative and current fire testing standard. With its associated testing standard, example BS 476:22, the maximum height of drywall systems also restricted by the test furnace height, predominate test furnace heights are typically 3 metres.

- To understand the true maximum height of drywall systems when following requirements to BS 476-20 it is possible to increase maximum heights based on 'cold state'. The determination the maximum height for drywall systems the mechanical stiffness of the systems follow: $L/240 @ 200$ Pascals (where L = spanning height of the system).
- The limiting level of mid-height lateral deflection of $L/240$ is considered as the serviceability limit state and is suitable for most painted or plastered finishes. The uniformly applied pressure of 200 Pascals (0.2kN/m^2), is considered as a reasonable maximum, with sufficient safety margin, for typical internal applications whilst under fire test conditions, known as 'fire state height'.

Regulatory Requirement

- Specific to Approved Document B (England) there is requirement to use European testing and classification standards. For non-loadbearing drywall systems* testing to BS EN 1363-1, BS EN 1364-1 and classifying systems to BS EN 13501-2 is required, which means that the 'fire state' height must be considered. All tests are required to be classified in accordance with BS EN 13501-2. It is also important to note, Approved Document B (England) also currently allows requirements to BS 476 series. BS 476 series will be removed in 2029. Adoption of such standards can support construction projects where BS compliance is required. For other nationals, please consult relevant approved documents, technical guidance, and handbooks.

Knauf Approach & Recommendations

- Knauf advise and advocate testing to support EN compliance projects, utilising, BS EN 1363-1, BS EN 1364-1 and fire classification to BS EN 13501-2, where non-loadbearing partitions, linings and shaftwall systems are required. The extension of maximum heights of non-loadbearing drywall systems are supported by either BS EN 15254-3 or BS EN 1364-1. Alternatively fire resistance test to the required height.
- Projects that wish to use the BS 476 series must gain agreement between the Client, Accountable Persons, Duty Holders, and Local Building Control that the cold state height is an acceptable methodology.



Dedicated support

For further information and understanding of Knauf systems to support either EN or BS Compliance projects, please contact our Technical Services:

Email: technical-uk@knauf.com
Tel: 0800 521050 (option 2).

* Performer (Partitions), Performer (Partitions with Resilient Bar), Isolator (Twin Frame), Shaftwall, Smokeshaft, and Independent 'I' Stud Lining



CCPI
Assessed Product
Information for Knauf
Performer, Isolator and
Shaftwall systems

Knauf Drywall Systems

Knauf Performer Partition Systems

The Knauf Performer system is our most versatile and commonly used partition system. It is constructed using a single row of Knauf metal studs ('C', 'I', 'MW') with Knauf plasterboards to both sides in order to meet fire, acoustic, moisture and impact requirements. The Performer system is lightweight, simple to construct and should be used in conjunction with Knauf's finishing solutions range.

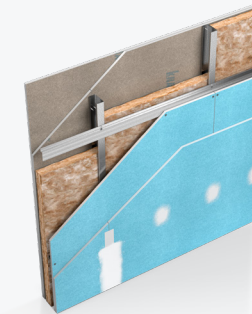

Knauf Performer Partition with Knauf Resilient Bar

Knauf Resilient Bar can be added to one side of certain Knauf Performer systems. This additional component improves the acoustic sound reduction performance of the system in order to meet higher acoustic requirements.

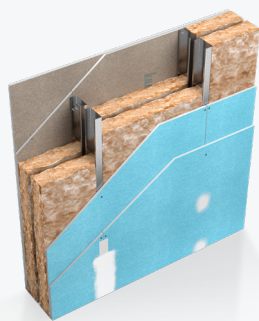

Knauf Isolator (Twin Frame) Partition and Knauf Isolator (Twin Frame) Partition - Hybrid

The Knauf Isolator system is typically used to divide habitable dwellings. The twin stud build up, combined with Knauf's high performance plasterboards, maximises acoustic performance in order to comply with building regulations, technical handbooks and guidances for sound insulation.

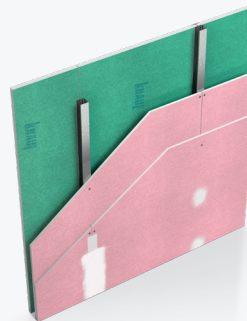

Knauf Shaftwall

Knauf Shaftwall is our innovative system to form enclosures around service and lift shafts while working from one side. The unique Knauf 'C-T' Stud makes this possible with a minimum of components. The system can provide a high level of fire resistance performance to meet the requirements of your project.

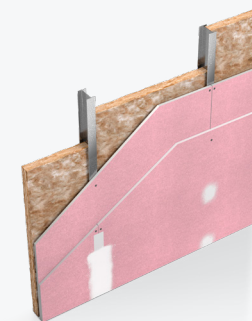

Knauf 'I' Stud Linings

Knauf Independent 'I' Stud is a fully independent wall lining system that can be used in all building types to upgrade the acoustic, fire and thermal performance of an existing masonry wall and to deal with any irregularities. Due to the system using an Knauf 'I' Stud, there is no requirement for the lining system to be fixed back into the structure behind.

Knauf Drywall Systems

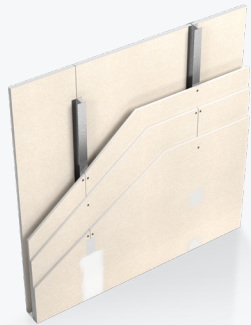

Knauf Smokeshaft

Knauf Smokeshaft is a system to be used when an A1 fire classification board (in accordance with BS EN 13501-1) is required to line a shaft.

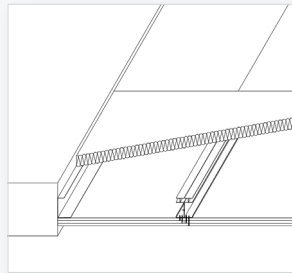

Knauf Horizontal Shaftwall - Ceiling System

Knauf Horizontal Shaftwall - Ceiling System is our innovative, non-loadbearing independent ceiling system (membrane) providing fire resistance from below and or from above. The unique arrangement allows the system to be built from one side.

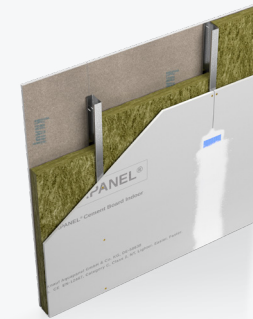

Knauf AQUAPANEL® Cement Board Indoor Board / Interior System

Knauf AQUAPANEL® Cement Board Indoor is exceptionally tough and durable, providing a solid tile backing substrate for wet indoor areas such as swimming pools, leisure centres, bathrooms and kitchens. The board is used in conjunction with specialist screws and finishing products to provide a full Knauf solution for humid and wet conditions.

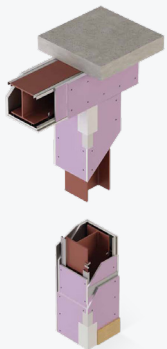

Knauf Framed Encasement System - Fire Panel

Knauf Framed Encasement System is a specialist fire protection encasement system designed to protect loadbearing universal beams and or columns. The use of Knauf Fire Panel plasterboard and specialist encasement Knauf components provide a simple and easy to install system.



Knauf Frameless Encasement System - Fireboard

Knauf Frameless Encasement System is another specialist fire protection encasement system designed to protect loadbearing universal beams and or columns. The use of Knauf Fireboard can be fixed together using staples without any Knauf metal components.

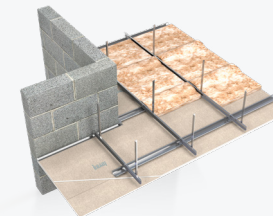

Knauf Metal Furring (MF) Suspended Ceiling System

The Knauf Metal Furring (MF) Suspended Ceiling system is versatile and easy to install. Deep voids are easily created to hide services and the ceiling can be used to provide fire protection to the soffit above. The Knauf MF Suspended Ceiling system is very familiar to contractors who will easily be able to form openings, bulkheads and coffers.

Table Guide

Specifications to support EN and BS compliance schemes

Section contents page

Specification identifier

The system code is a unique code that allows for easy reference if enquiring about a system.

EN-PC-50-055-6-1-15-WB-0

EN	This is the standard in which this is accepted
PC	System name (Performer) and stud type (C)
50	Stud depth 50 (mm)
055	Stud gauge 0.55 (mm)
6	Stud centres, 6= 600, 4= 400 and 3=300 (mm)
1	Layers of plasterboard on either side
15	Thickness of each individual board
WB	Plasterboard type (Wallboard)
0	Thickness in mm of insulation in cavity

The number of layers Knauf plasterboard fixed to either side of Knauf metal stud frame

Knauf plasterboard/ board type

System width (in mm) which excludes finishes

Acoustic Sound Insulation of system in measured in dB(Rw)

Relates to specific deflection head construction detail

Knauf Stud depth and gauge (mm)	Knauf Plasterboard layers to each side of Knauf Stud (no)	Thickness of Knauf Plasterboard (mm)	Knauf Plasterboard	Knauf Insulation Acoustic Roll - Cavity Insulation (mm)	System width (mm) excluding finishes	System code & Maximum height ¹ (mm) @ 600mm centres	System code & Maximum height ¹ (mm) @ 400mm centres	System code & Maximum height ¹ (mm) @ 300mm centres	Fire resistance period ² (minutes)	Acoustic Sound Insulation ³ (dB Rw)	Deflection allowance (mm)	Deflection head arrangement			
50'C Stud (0.55)	1	15	Wallboard	Non Insulated	82	EN-PC-50-055-6-1-15-WB-0	3100	EN-PC-50-055-4-1-15-WB-0	3300	EN-PC-50-055-3-1-15-WB-0	3500	30	42	-25	Figure X

Knauf metal component information providing size and gauge

Thickness of Knauf plasterboard/ board

Thickness of insulation used within Knauf metal stud frame. Refer to tables for information of Knauf Insulation type

Partition height (in mm)

Classified fire resistance performance, both fire integrity and fire insulation of system measured in minutes

Direction and amount of deflection accommodated at head of system

NB: Additional pre-fixes are added for some system codes to summarise width of walls and fire performance of fire performance only.
 Examples below:
 (250/120) = 250mm width wall with 120 mins fire resistance
 (60) = 60 fire mins resistance

EN COMPLIANCE SPECIFICATION TABLES

Our systems

- **Knauf Performer Partition Systems**
 - Knauf Wallboard Solutions
 - Knauf Moisture Panel Solutions
 - Knauf Fire Panel Solutions
 - Knauf Soundshield Plus Solutions
 - Knauf Performance Plus Solutions
- **Knauf Performer – 'MW' Acoustic Studs**
- **Knauf Performer – 'I' Stud Solution**
- **Knauf Performer – Resilient Bar**
- **Knauf AQUAPANEL® Interior System**
- **Knauf Isolator (Twin Frame) Partitions**
- **Knauf Isolator (Twin Frame) Partitions - Hybrid**
- **Knauf Shaftwall**
- **Knauf 'I' Stud Linings: Fire Resistance Performance Systems**
- **Knauf 'I' Stud Linings: Non-Resistance Performance Systems**
- **Knauf Smokeshaft**
- **Knauf Horizontal Shaftwall – Ceiling System**
- **Knauf Metal Furring (MF) Suspended Ceiling Systems**

Knauf Performer - Wallboard (EN Compliance)



Got a question? Email our Technical Service on technical-uk@knauf.com or call 0800 521050 (option 2)

50mm Stud Solutions

Knauf Stud depth and gauge (mm)	Knauf Plasterboard layers to each side of Knauf Stud (no)	Thickness of Knauf Plasterboard (mm)	Knauf Plasterboard	Knauf Insulation Acoustic Roll - Cavity Insulation (mm)	System width (mm) excluding finishes	System code & Maximum height ¹ (mm) @ 600mm centres	System code & Maximum height ¹ (mm) @ 400mm centres	System code & Maximum height ¹ (mm) @ 300mm centres	Fire resistance period ² (minutes)	Acoustic Sound Insulation ³ (dB Rw)	Deflection allowance (mm)	Deflection head arrangement			
50'C Stud (0.55)	1	12.5	Wallboard	Non Insulated	77	EN-PC-50-055-6-1-12.5-WB-0	3000	EN-PC-50-055-4-1-12.5-WB-0	3200	EN-PC-50-055-3-1-12.5-WB-0	3400	NA	34	-25	Figure 1
	1	12.5	Wallboard	25	77	EN-PC-50-055-6-1-12.5-WB-25	3000	EN-PC-50-055-4-1-12.5-WB-25	3200	EN-PC-50-055-3-1-12.5-WB-25	3400	30	42	-25	Figure 3
	1	15	Wallboard	Non Insulated	82	EN-PC-50-055-6-1-15-WB-0	3100	EN-PC-50-055-4-1-15-WB-0	3300	EN-PC-50-055-3-1-15-WB-0	3500	30	36	-25	Figure 1
	1	15	Wallboard	25	82	EN-PC-50-055-6-1-15-WB-25	3100	EN-PC-50-055-4-1-15-WB-25	3300	EN-PC-50-055-3-1-15-WB-25	3500	Not Tested	42	-25	Figure 3
	2	12.5	Wallboard	Non Insulated	102	EN-PC-50-055-6-2-12.5-WB-0	3700	EN-PC-50-055-4-2-12.5-WB-0	3800	EN-PC-50-055-3-2-12.5-WB-0	4000	60	42	-25	Figure 2
	2	12.5	Wallboard	25	102	EN-PC-50-055-6-2-12.5-WB-25	3700	EN-PC-50-055-4-2-12.5-WB-25	3800	EN-PC-50-055-3-2-12.5-WB-25	4000	60	49	-25	Figure 4
	2	15	Wallboard	Non Insulated	112	EN-PC-50-055-6-2-15-WB-0	3900	EN-PC-50-055-4-2-15-WB-0	4000	EN-PC-50-055-3-2-15-WB-0	4200	60	45	-25	Figure 2
	2	15	Wallboard	25	112	EN-PC-50-055-6-2-15-WB-25	3900	EN-PC-50-055-4-2-15-WB-25	4000	EN-PC-50-055-3-2-15-WB-25	4200	Not Tested	51	-25	Figure 4

70mm Stud Solutions

Knauf Stud depth and gauge (mm)	Knauf Plasterboard layers to each side of Knauf Stud (no)	Thickness of Knauf Plasterboard (mm)	Knauf Plasterboard	Knauf Insulation Acoustic Roll - Cavity Insulation (mm)	System width (mm) excluding finishes	System code & Maximum height ¹ (mm) @ 600mm centres	System code & Maximum height ¹ (mm) @ 400mm centres	System code & Maximum height ¹ (mm) @ 300mm centres	Fire resistance period ² (minutes)	Acoustic Sound Insulation ³ (dB Rw)	Deflection allowance (mm)	Deflection head arrangement			
70'C Stud (0.55)	1	12.5	Wallboard	Non Insulated	97	EN-PC-70-055-6-1-12.5-WB-0	3600	EN-PC-70-055-4-1-12.5-WB-0	3900	EN-PC-70-055-3-1-12.5-WB-0	4200	NA	35	-25	Figure 1
	1	12.5	Wallboard	Non Insulated	97	EN-PC-70-055-6-1-12.5-WB-0	3600	EN-PC-70-055-4-1-12.5-WB-0	3900	EN-PC-70-055-3-1-12.5-WB-0	4200	NA	35	-50	Figure 5
	1	12.5	Wallboard	25	97	EN-PC-70-055-6-1-12.5-WB-25	3600	EN-PC-70-055-4-1-12.5-WB-25	3900	EN-PC-70-055-3-1-12.5-WB-25	4200	30	42	-25	Figure 3
	1	12.5	Wallboard	25	97	EN-PC-70-055-6-1-12.5-WB-25	3600	EN-PC-70-055-4-1-12.5-WB-25	3900	EN-PC-70-055-3-1-12.5-WB-25	4000	30	42	-50	Figure 7
	1	15	Wallboard	Non Insulated	102	EN-PC-70-055-6-1-15-WB-0	4000	EN-PC-70-055-4-1-15-WB-0	4300	EN-PC-70-055-3-1-15-WB-0	4500	30	37	-25	Figure 1
	1	15	Wallboard	Non Insulated	102	EN-PC-70-055-6-1-15-WB-0	4000	EN-PC-70-055-4-1-15-WB-0	4300	EN-PC-70-055-3-1-15-WB-0	4500	30	37	-50	Figure 5
	1	15	Wallboard	25	102	EN-PC-70-055-6-1-15-WB-25	4000	EN-PC-70-055-4-1-15-WB-25	4300	EN-PC-70-055-3-1-15-WB-25	4500	30	43	-25	Figure 3
	1	15	Wallboard	25	102	EN-PC-70-055-6-1-15-WB-25	4000	EN-PC-70-055-4-1-15-WB-25	4000	EN-PC-70-055-3-1-15-WB-25	4000	30	43	-50	Figure 7
	2	12.5	Wallboard	Non Insulated	122	EN-PC-70-055-6-2-12.5-WB-0	4500	EN-PC-70-055-4-2-12.5-WB-0	4700	EN-PC-70-055-3-2-12.5-WB-0	4900	60	43	-25	Figure 2
	2	12.5	Wallboard	Non Insulated	122	EN-PC-70-055-6-2-12.5-WB-0	4500	EN-PC-70-055-4-2-12.5-WB-0	4700	EN-PC-70-055-3-2-12.5-WB-0	4900	60	43	-50	Figure 6
	2	12.5	Wallboard	25	122	EN-PC-70-055-6-2-12.5-WB-25	4000	EN-PC-70-055-4-2-12.5-WB-25	4000	EN-PC-70-055-3-2-12.5-WB-25	4000	60	52	-25	Figure 4
	2	12.5	Wallboard	25	122	EN-PC-70-055-6-2-12.5-WB-25	4000	EN-PC-70-055-4-2-12.5-WB-25	4000	EN-PC-70-055-3-2-12.5-WB-25	4000	60	52	-50	Figure 8
	2	15	Wallboard	Non Insulated	132	EN-PC-70-055-6-2-15-WB-0	4800	EN-PC-70-055-4-2-15-WB-0	5000	EN-PC-70-055-3-2-15-WB-0	5000	60	46	-25	Figure 2
	2	15	Wallboard	Non Insulated	132	EN-PC-70-055-6-2-15-WB-0	4000	EN-PC-70-055-4-2-15-WB-0	4000	EN-PC-70-055-3-2-15-WB-0	4000	60	46	-50	Figure 6
	2	15	Wallboard	25	132	EN-PC-70-055-6-2-15-WB-25	4800	EN-PC-70-055-4-2-15-WB-25	5000	EN-PC-70-055-3-2-15-WB-25	5000	60	54	-25	Figure 4
	2	15	Wallboard	25	132	EN-PC-70-055-6-2-15-WB-25	4800	EN-PC-70-055-4-2-15-WB-25	5000	EN-PC-70-055-3-2-15-WB-25	5000	60	54	-50	Figure 8

1. **Maximum height for EN Compliance Systems:** The stated maximum height figure is the lower value between maximum cold state height, calculated to limiting deflection of L/240 @ 200 Pascals and the fire state height, as outlined in accordance with BS EN 1364-1 and BS EN 15254-3.
 2. **Fire resistance period:** Tested in accordance with BS EN 1364-1. Fire resistance period is inclusive of fire integrity and fire insulation (EI). Fire resistance performance must be reviewed against Knauf specifications and standard details.
 3. **Acoustic sound insulation:** Tested or assessed in accordance with BS EN ISO 10140-1 and BS EN 10140-2. Important - Acoustic Sound Insulation Performance based on Knauf studs at 600mm centres and non-deflection arrangement. Systems that are fire resistance and / or offering acoustic sound performance must have all outer joints taped and filled in accordance with Knauf recommendations. Systems are tested as imperforate.

EN Compliance Specifications

Knauf Performer - Wallboard (EN Compliance)



Got a question? Email our Technical Service on technical-uk@knauf.com or call 0800 521050 (option 2)

92mm Stud Solutions

Knauf Stud depth and gauge (mm)	Knauf Plasterboard layers to each side of Knauf Stud (no)	Thickness of Knauf Plasterboard (mm)	Knauf Plasterboard	Knauf Insulation Acoustic Roll - Cavity Insulation (mm)	System width (mm) excluding finishes	System code & Maximum height ¹ (mm) @ 600mm centres	System code & Maximum height ¹ (mm) @ 400mm centres	System code & Maximum height ¹ (mm) @ 300mm centres	Fire resistance period ² (minutes)	Acoustic Sound Insulation ³ (dB Rw)	Deflection allowance (mm)	Deflection head arrangement	
92 'C' Stud (0.70)	1	12.5	Wallboard	Non Insulated	119	EN-PC-92-070-6-1-12.5-WB-0	4900	EN-PC-92-070-4-1-12.5-WB-0	5600	NA	35	-25	Figure 1
	1	12.5	Wallboard	Non Insulated	119	EN-PC-92-070-6-1-12.5-WB-0	4900	EN-PC-92-070-4-1-12.5-WB-0	5600	NA	35	-50	Figure 5
	1	12.5	Wallboard	25	119	EN-PC-92-070-6-1-12.5-WB-25	4900	EN-PC-92-070-4-1-12.5-WB-25	5000	30	42	-25	Figure 3
	1	12.5	Wallboard	25	119	EN-PC-92-070-6-1-12.5-WB-25	4000	EN-PC-92-070-4-1-12.5-WB-25	4000	30	42	-50	Figure 7
	1	15	Wallboard	Non Insulated	124	EN-PC-92-070-6-1-15-WB-0	5000	EN-PC-92-070-4-1-15-WB-0	5000	30	37	-25	Figure 1
	1	15	Wallboard	Non Insulated	124	EN-PC-92-070-6-1-15-WB-0	5000	EN-PC-92-070-4-1-15-WB-0	5000	30	37	-50	Figure 5
	1	15	Wallboard	25	124	EN-PC-92-070-6-1-15-WB-25	5000	EN-PC-92-070-4-1-15-WB-25	5000	30	43	-25	Figure 3
	1	15	Wallboard	25	124	EN-PC-92-070-6-1-15-WB-25	4000	EN-PC-92-070-4-1-15-WB-25	4000	30	43	-50	Figure 7
	2	12.5	Wallboard	Non Insulated	144	EN-PC-92-070-6-2-12.5-WB-0	5000	EN-PC-92-070-4-2-12.5-WB-0	5000	60	43	-25	Figure 2
	2	12.5	Wallboard	Non Insulated	144	EN-PC-92-070-6-2-12.5-WB-0	5000	EN-PC-92-070-4-2-12.5-WB-0	5000	60	43	-50	Figure 6
	2	12.5	Wallboard	25	144	EN-PC-92-070-6-2-12.5-WB-25	4000	EN-PC-92-070-4-2-12.5-WB-25	4000	60	52	-25	Figure 4
	2	12.5	Wallboard	25	144	EN-PC-92-070-6-2-12.5-WB-25	4000	EN-PC-92-070-4-2-12.5-WB-25	4000	60	52	-50	Figure 8
	2	15	Wallboard	Non Insulated	154	EN-PC-92-070-6-2-15-WB-0	5000	EN-PC-92-070-4-2-15-WB-0	5000	60	46	-25	Figure 2
	2	15	Wallboard	Non Insulated	154	EN-PC-92-070-6-2-15-WB-0	4000	EN-PC-92-070-4-2-15-WB-0	4000	60	46	-50	Figure 6
	2	15	Wallboard	25	154	EN-PC-92-070-6-2-15-WB-25	5000	EN-PC-92-070-4-2-15-WB-25	5000	60	54	-25	Figure 4
	2	15	Wallboard	25	154	EN-PC-92-070-6-2-15-WB-25	5000	EN-PC-92-070-4-2-15-WB-25	5000	60	54	-50	Figure 8

146mm Stud Solutions

Knauf Stud depth and gauge (mm)	Knauf Plasterboard layers to each side of Knauf Stud (no)	Thickness of Knauf Plasterboard (mm)	Knauf Plasterboard	Knauf Insulation Acoustic Roll - Cavity Insulation (mm)	System width (mm) excluding finishes	System code & Maximum height ¹ (mm) @ 600mm centres	System code & Maximum height ¹ (mm) @ 400mm centres	System code & Maximum height ¹ (mm) @ 300mm centres	Fire resistance period ² (minutes)	Acoustic Sound Insulation ³ (dB Rw)	Deflection allowance (mm)	Deflection head arrangement	
146 'C' Stud (0.55)	1	12.5	Wallboard	Non Insulated	173	EN-PC-146-055-6-1-12.5-WB-0	5800	EN-PC-146-055-4-1-12.5-WB-0	7000	NA	35	-25	Figure 1
	1	12.5	Wallboard	Non Insulated	173	EN-PC-146-055-6-1-12.5-WB-0	5800	EN-PC-146-055-4-1-12.5-WB-0	7000	NA	35	-50	Figure 5
	1	12.5	Wallboard	25	173	EN-PC-146-055-6-1-12.5-WB-25	5000	EN-PC-146-055-4-1-12.5-WB-25	5000	30	42	-25	Figure 3
	1	12.5	Wallboard	25	173	EN-PC-146-055-6-1-12.5-WB-25	4000	EN-PC-146-055-4-1-12.5-WB-25	4000	30	42	-50	Figure 7
	1	15	Wallboard	Non Insulated	178	EN-PC-146-055-6-1-15-WB-0	5000	EN-PC-146-055-4-1-15-WB-0	5000	30	37	-25	Figure 1
	1	15	Wallboard	Non Insulated	178	EN-PC-146-055-6-1-15-WB-0	5000	EN-PC-146-055-4-1-15-WB-0	5000	30	37	-50	Figure 5
	1	15	Wallboard	25	178	EN-PC-146-055-6-1-15-WB-25	5000	EN-PC-146-055-4-1-15-WB-25	5000	30	43	-25	Figure 3
	1	15	Wallboard	25	178	EN-PC-146-055-6-1-15-WB-25	4000	EN-PC-146-055-4-1-15-WB-25	4000	30	43	-50	Figure 7
	2	12.5	Wallboard	Non Insulated	198	EN-PC-146-055-6-2-12.5-WB-0	5000	EN-PC-146-055-4-2-12.5-WB-0	5000	60	49	-25	Figure 2
	2	12.5	Wallboard	Non Insulated	198	EN-PC-146-055-6-2-12.5-WB-0	5000	EN-PC-146-055-4-2-12.5-WB-0	5000	60	49	-50	Figure 6
	2	12.5	Wallboard	25	198	EN-PC-146-055-6-2-12.5-WB-25	4000	EN-PC-146-055-4-2-12.5-WB-25	4000	60	53	-25	Figure 4
	2	12.5	Wallboard	25	198	EN-PC-146-055-6-2-12.5-WB-25	4000	EN-PC-146-055-4-2-12.5-WB-25	4000	60	53	-50	Figure 8
	2	15	Wallboard	Non Insulated	208	EN-PC-146-055-6-2-15-WB-0	5000	EN-PC-146-055-4-2-15-WB-0	5000	60	50	-25	Figure 2
	2	15	Wallboard	Non Insulated	208	EN-PC-146-055-6-2-15-WB-0	4000	EN-PC-146-055-4-2-15-WB-0	4000	60	50	-50	Figure 6
	2	15	Wallboard	25	208	EN-PC-146-055-6-2-15-WB-25	5000	EN-PC-146-055-4-2-15-WB-25	5000	60	54	-25	Figure 4
	2	15	Wallboard	25	208	EN-PC-146-055-6-2-15-WB-25	5000	EN-PC-146-055-4-2-15-WB-25	5000	60	54	-50	Figure 8

1. **Maximum height for EN Compliance Systems:** The stated maximum height figure is the lower value between maximum cold state height, calculated to limiting deflection of L/240 @ 200 Pascals and the fire state height, as outlined in accordance with BS EN 1364-1 and BS EN 15254-3.
 2. **Fire resistance period:** Tested in accordance with BS EN 1364-1. Fire resistance period is inclusive of fire integrity and fire insulation (EI). Fire resistance performance must be reviewed against Knauf specifications and standard details.
 3. **Acoustic sound insulation:** Tested or assessed in accordance with BS EN ISO 10140-1 and BS EN 10140-2. Important - Acoustic Sound Insulation Performance based on Knauf studs at 600mm centres and non-deflection arrangement. Systems that are fire resistance and / or offering acoustic sound performance must have all outer joints taped and filled in accordance with Knauf recommendations. Systems are tested as imperforate.

EN Compliance Specifications

Knauf Performer - Moisture Panel (EN Compliance)



Got a question? Email our Technical Service on technical-uk@knauf.com or call 0800 521050 (option 2)

50mm Stud Solutions

Knauf Stud depth and gauge (mm)	Knauf Plasterboard layers to each side of Knauf Stud (no)	Thickness of Knauf Plasterboard (mm)	Knauf Plasterboard	Knauf Insulation Acoustic Roll - Cavity Insulation (mm)	System width (mm) excluding finishes	System code & Maximum height ¹ (mm) @ 600mm centres	System code & Maximum height ¹ (mm) @ 400mm centres	System code & Maximum height ¹ (mm) @ 300mm centres	Fire resistance period ² (minutes)	Acoustic Sound Insulation ³ (dB Rw)	Deflection allowance (mm)	Deflection head arrangement			
50 'C' Stud (0.55)	1	12.5	Moisture Panel	Non Insulated	77	EN-PC-50-055-6-1-12.5-MP-0	3000	EN-PC-50-055-4-1-12.5-MP-0	3200	EN-PC-50-055-3-1-12.5-MP-0	3400	NA	34	-25	Figure 1
	1	12.5	Moisture Panel	25	77	EN-PC-50-055-6-1-12.5-MP-25	3000	EN-PC-50-055-4-1-12.5-MP-25	3200	EN-PC-50-055-3-1-12.5-MP-25	3400	30	42	-25	Figure 3
	1	15	Moisture Panel	Non Insulated	82	EN-PC-50-055-6-1-15-MP-0	3100	EN-PC-50-055-4-1-15-MP-0	3300	EN-PC-50-055-3-1-15-MP-0	3500	30	36	-25	Figure 1
	1	15	Moisture Panel	25	82	EN-PC-50-055-6-1-15-MP-25	3100	EN-PC-50-055-4-1-15-MP-25	3300	EN-PC-50-055-3-1-15-MP-25	3500	Not Tested	42	-25	Figure 3
	2	12.5	Moisture Panel	Non Insulated	102	EN-PC-50-055-6-2-12.5-MP-0	3700	EN-PC-50-055-4-2-12.5-MP-0	3800	EN-PC-50-055-3-2-12.5-MP-0	4000	60	42	-25	Figure 2
	2	12.5	Moisture Panel	25	102	EN-PC-50-055-6-2-12.5-MP-25	3700	EN-PC-50-055-4-2-12.5-MP-25	3800	EN-PC-50-055-3-2-12.5-MP-25	4000	Not Tested	49	-25	Figure 4
	2	15	Moisture Panel	Non Insulated	112	EN-PC-50-055-6-2-15-MP-0	3900	EN-PC-50-055-4-2-15-MP-0	4000	EN-PC-50-055-3-2-15-MP-0	4200	60	45	-25	Figure 2
	2	15	Moisture Panel	25	112	EN-PC-50-055-6-2-15-MP-25	3900	EN-PC-50-055-4-2-15-MP-25	4000	EN-PC-50-055-3-2-15-MP-25	4200	Not Tested	51	-25	Figure 4

70mm Stud Solutions

Knauf Stud depth and gauge (mm)	Knauf Plasterboard layers to each side of Knauf Stud (no)	Thickness of Knauf Plasterboard (mm)	Knauf Plasterboard	Knauf Insulation Acoustic Roll - Cavity Insulation (mm)	System width (mm) excluding finishes	System code & Maximum height ¹ (mm) @ 600mm centres	System code & Maximum height ¹ (mm) @ 400mm centres	System code & Maximum height ¹ (mm) @ 300mm centres	Fire resistance period ² (minutes)	Acoustic Sound Insulation ³ (dB Rw)	Deflection allowance (mm)	Deflection head arrangement			
70 'C' Stud (0.55)	1	12.5	Moisture Panel	Non Insulated	97	EN-PC-70-055-6-1-12.5-MP-0	3600	EN-PC-70-055-4-1-12.5-MP-0	3900	EN-PC-70-055-3-1-12.5-MP-0	4200	NA	35	-25	Figure 1
	1	12.5	Moisture Panel	Non Insulated	97	EN-PC-70-055-6-1-12.5-MP-0	3600	EN-PC-70-055-4-1-12.5-MP-0	3900	EN-PC-70-055-3-1-12.5-MP-0	4200	NA	35	-50	Figure 5
	1	12.5	Moisture Panel	25	97	EN-PC-70-055-6-1-12.5-MP-25	3600	EN-PC-70-055-4-1-12.5-MP-25	3900	EN-PC-70-055-3-1-12.5-MP-25	4200	30	42	-25	Figure 3
	1	12.5	Moisture Panel	25	97	EN-PC-70-055-6-1-12.5-MP-25	3600	EN-PC-70-055-4-1-12.5-MP-25	3900	EN-PC-70-055-3-1-12.5-MP-25	4000	30	42	-50	Figure 7
	1	15	Moisture Panel	Non Insulated	102	EN-PC-70-055-6-1-15-MP-0	4000	EN-PC-70-055-4-1-15-MP-0	4300	EN-PC-70-055-3-1-15-MP-0	4500	30	37	-25	Figure 1
	1	15	Moisture Panel	Non Insulated	102	EN-PC-70-055-6-1-15-MP-0	4000	EN-PC-70-055-4-1-15-MP-0	4300	EN-PC-70-055-3-1-15-MP-0	4500	30	37	-50	Figure 5
	1	15	Moisture Panel	25	102	EN-PC-70-055-6-1-15-MP-25	4000	EN-PC-70-055-4-1-15-MP-25	4300	EN-PC-70-055-3-1-15-MP-25	4500	30	43	-25	Figure 3
	1	15	Moisture Panel	25	102	EN-PC-70-055-6-1-15-MP-25	4000	EN-PC-70-055-4-1-15-MP-25	4000	EN-PC-70-055-3-1-15-MP-25	4000	30	43	-50	Figure 7
	2	12.5	Moisture Panel	Non Insulated	122	EN-PC-70-055-6-2-12.5-MP-0	4500	EN-PC-70-055-4-2-12.5-MP-0	4700	EN-PC-70-055-3-2-12.5-MP-0	4900	60	43	-25	Figure 2
	2	12.5	Moisture Panel	Non Insulated	122	EN-PC-70-055-6-2-12.5-MP-0	4500	EN-PC-70-055-4-2-12.5-MP-0	4700	EN-PC-70-055-3-2-12.5-MP-0	4900	60	43	-50	Figure 6
	2	12.5	Moisture Panel	25	122	EN-PC-70-055-6-2-12.5-MP-25	4500	EN-PC-70-055-4-2-12.5-MP-25	4700	EN-PC-70-055-3-2-12.5-MP-25	4900	Not Tested	52	-25	Figure 4
	2	12.5	Moisture Panel	25	122	EN-PC-70-055-6-2-12.5-MP-25	4500	EN-PC-70-055-4-2-12.5-MP-25	4700	EN-PC-70-055-3-2-12.5-MP-25	4900	Not Tested	52	-50	Figure 8
	2	15	Moisture Panel	Non Insulated	132	EN-PC-70-055-6-2-15-MP-0	4800	EN-PC-70-055-4-2-15-MP-0	5000	EN-PC-70-055-3-2-15-MP-0	5000	30*	46	-25	Figure 2
	2	15	Moisture Panel	Non Insulated	132	EN-PC-70-055-6-2-15-MP-0	4800	EN-PC-70-055-4-2-15-MP-0	5000	EN-PC-70-055-3-2-15-MP-0	5000	30*	46	-50	Figure 6
	2	15	Moisture Panel	25	132	EN-PC-70-055-6-2-15-MP-25	4800	EN-PC-70-055-4-2-15-MP-25	5000	EN-PC-70-055-3-2-15-MP-25	5000	30*	54	-25	Figure 4
	2	15	Moisture Panel	25	132	EN-PC-70-055-6-2-15-MP-25	4800	EN-PC-70-055-4-2-15-MP-25	5000	EN-PC-70-055-3-2-15-MP-25	5000	30*	54	-50	Figure 8

*System performance based on single layer system

1. Maximum height for EN Compliance Systems: The stated maximum height figure is the lower value between maximum cold state height, calculated to limiting deflection of L/240 @ 200 Pascals and the fire state height, as outlined in accordance with BS EN 1364-1 and BS EN 15254-3.
2. Fire resistance period: Tested in accordance with BS EN 1364-1. Fire resistance period is inclusive of fire integrity and fire insulation (EI). Fire resistance performance must be reviewed against Knauf specifications and standard details.
3. Acoustic sound insulation: Tested or assessed in accordance with BS EN ISO 10140-1 and BS EN 10140-2. Important - Acoustic Sound Insulation Performance based on Knauf studs at 600mm centres and non-deflection arrangement. Systems that are fire resistance and / or offering acoustic sound performance must have all outer joints taped and filled in accordance with Knauf recommendations. Systems are tested as imperforate.

EN Compliance Specifications

Knauf Performer - Moisture Panel (EN Compliance)



Got a question? Email our Technical Service on technical-uk@knauf.com or call 0800 521050 (option 2)

92mm Stud Solutions

Knauf Stud depth and gauge (mm)	Knauf Plasterboard layers to each side of Knauf Stud (no)	Thickness of Knauf Plasterboard (mm)	Knauf Plasterboard	Knauf Insulation Acoustic Roll - Cavity Insulation (mm)	System width (mm) excluding finishes	System code & Maximum height ¹ (mm) @ 600mm centres	System code & Maximum height ¹ (mm) @ 400mm centres	System code & Maximum height ¹ (mm) @ 300mm centres	Fire resistance period ² (minutes)	Acoustic Sound Insulation ³ (dB Rw)	Deflection allowance (mm)	Deflection head arrangement			
92'C Stud (0.70)	1	12.5	Moisture Panel	Non Insulated	119	EN-PC-92-070-6-1-12.5-MP-0	4900	EN-PC-92-070-4-1-12.5-MP-0	5300	EN-PC-92-070-3-1-12.5-MP-0	5600	NA	35	-25	Figure 1
	1	12.5	Moisture Panel	Non Insulated	119	EN-PC-92-070-6-1-12.5-MP-0	4900	EN-PC-92-070-4-1-12.5-MP-0	5300	EN-PC-92-070-3-1-12.5-MP-0	5600	NA	35	-50	Figure 5
	1	12.5	Moisture Panel	25	119	EN-PC-92-070-6-1-12.5-MP-25	4900	EN-PC-92-070-4-1-12.5-MP-25	5000	EN-PC-92-070-3-1-12.5-MP-25	5000	30	42	-25	Figure 3
	1	12.5	Moisture Panel	25	119	EN-PC-92-070-6-1-12.5-MP-25	4000	EN-PC-92-070-4-1-12.5-MP-25	4000	EN-PC-92-070-3-1-12.5-MP-25	4000	30	42	-50	Figure 7
	1	15	Moisture Panel	Non Insulated	124	EN-PC-92-070-6-1-15-MP-0	5000	EN-PC-92-070-4-1-15-MP-0	5000	EN-PC-92-070-3-1-15-MP-0	5000	30	37	-25	Figure 1
	1	15	Moisture Panel	Non Insulated	124	EN-PC-92-070-6-1-15-MP-0	5000	EN-PC-92-070-4-1-15-MP-0	5000	EN-PC-92-070-3-1-15-MP-0	5000	30	37	-50	Figure 5
	1	15	Moisture Panel	25	124	EN-PC-92-070-6-1-15-MP-25	5000	EN-PC-92-070-4-1-15-MP-25	5000	EN-PC-92-070-3-1-15-MP-25	5000	30	43	-25	Figure 3
	1	15	Moisture Panel	25	124	EN-PC-92-070-6-1-15-MP-25	4000	EN-PC-92-070-4-1-15-MP-25	4000	EN-PC-92-070-3-1-15-MP-25	4000	30	43	-50	Figure 7
	2	12.5	Moisture Panel	Non Insulated	144	EN-PC-92-070-6-2-12.5-MP-0	5000	EN-PC-92-070-4-2-12.5-MP-0	5000	EN-PC-92-070-3-2-12.5-MP-0	5000	60	43	-25	Figure 2
	2	12.5	Moisture Panel	Non Insulated	144	EN-PC-92-070-6-2-12.5-MP-0	5000	EN-PC-92-070-4-2-12.5-MP-0	5000	EN-PC-92-070-3-2-12.5-MP-0	5000	60	43	-50	Figure 6
	2	12.5	Moisture Panel	25	144	EN-PC-92-070-6-2-12.5-MP-25	5700	EN-PC-92-070-4-2-12.5-MP-25	6100	EN-PC-92-070-3-2-12.5-MP-25	6300	Not Tested	52	-25	Figure 4
	2	12.5	Moisture Panel	25	144	EN-PC-92-070-6-2-12.5-MP-25	5700	EN-PC-92-070-4-2-12.5-MP-25	6100	EN-PC-92-070-3-2-12.5-MP-25	6300	Not Tested	52	-50	Figure 8
	2	15	Moisture Panel	Non Insulated	154	EN-PC-92-070-6-2-15-MP-0	5000	EN-PC-92-070-4-2-15-MP-0	5000	EN-PC-92-070-3-2-15-MP-0	5000	30*	46	-25	Figure 2
	2	15	Moisture Panel	Non Insulated	154	EN-PC-92-070-6-2-15-MP-0	5000	EN-PC-92-070-4-2-15-MP-0	5000	EN-PC-92-070-3-2-15-MP-0	5000	30*	46	-50	Figure 6
	2	15	Moisture Panel	25	154	EN-PC-92-070-6-2-15-MP-25	5000	EN-PC-92-070-4-2-15-MP-25	5000	EN-PC-92-070-3-2-15-MP-25	5000	30*	54	-25	Figure 4
	2	15	Moisture Panel	25	154	EN-PC-92-070-6-2-15-MP-25	5000	EN-PC-92-070-4-2-15-MP-25	5000	EN-PC-92-070-3-2-15-MP-25	5000	30*	54	-50	Figure 8

146mm Stud Solutions

Knauf Stud depth and gauge (mm)	Knauf Plasterboard layers to each side of Knauf Stud (no)	Thickness of Knauf Plasterboard (mm)	Knauf Plasterboard	Knauf Insulation Acoustic Roll - Cavity Insulation (mm)	System width (mm) excluding finishes	System code & Maximum height ¹ (mm) @ 600mm centres	System code & Maximum height ¹ (mm) @ 400mm centres	System code & Maximum height ¹ (mm) @ 300mm centres	Fire resistance period ² (minutes)	Acoustic Sound Insulation ³ (dB Rw)	Deflection allowance (mm)	Deflection head arrangement			
146'C Stud (0.55)	1	12.5	Moisture Panel	Non Insulated	173	EN-PC-146-055-6-1-12.5-MP-0	5800	EN-PC-146-055-4-1-12.5-MP-0	6400	EN-PC-146-055-3-1-12.5-MP-0	7000	NA	35	-25	Figure 1
	1	12.5	Moisture Panel	Non Insulated	173	EN-PC-146-055-6-1-12.5-MP-0	5800	EN-PC-146-055-4-1-12.5-MP-0	6400	EN-PC-146-055-3-1-12.5-MP-0	7000	NA	35	-50	Figure 5
	1	12.5	Moisture Panel	25	173	EN-PC-146-055-6-1-12.5-MP-25	5000	EN-PC-146-055-4-1-12.5-MP-25	5000	EN-PC-146-055-3-1-12.5-MP-25	5000	30	42	-25	Figure 3
	1	12.5	Moisture Panel	25	173	EN-PC-146-055-6-1-12.5-MP-25	4000	EN-PC-146-055-4-1-12.5-MP-25	4000	EN-PC-146-055-3-1-12.5-MP-25	4000	30	42	-50	Figure 7
	1	15	Moisture Panel	Non Insulated	178	EN-PC-146-055-6-1-15-MP-0	5000	EN-PC-146-055-4-1-15-MP-0	5000	EN-PC-146-055-3-1-15-MP-0	5000	30	37	-25	Figure 1
	1	15	Moisture Panel	Non Insulated	178	EN-PC-146-055-6-1-15-MP-0	5000	EN-PC-146-055-4-1-15-MP-0	5000	EN-PC-146-055-3-1-15-MP-0	5000	30	37	-50	Figure 5
	1	15	Moisture Panel	25	178	EN-PC-146-055-6-1-15-MP-25	5000	EN-PC-146-055-4-1-15-MP-25	5000	EN-PC-146-055-3-1-15-MP-25	5000	30	43	-25	Figure 3
	1	15	Moisture Panel	25	178	EN-PC-146-055-6-1-15-MP-25	4000	EN-PC-146-055-4-1-15-MP-25	4000	EN-PC-146-055-3-1-15-MP-25	4000	30	43	-50	Figure 7
	2	12.5	Moisture Panel	Non Insulated	198	EN-PC-146-055-6-2-12.5-MP-0	5000	EN-PC-146-055-4-2-12.5-MP-0	5000	EN-PC-146-055-3-2-12.5-MP-0	5000	60	49	-25	Figure 2
	2	12.5	Moisture Panel	Non Insulated	198	EN-PC-146-055-6-2-12.5-MP-0	5000	EN-PC-146-055-4-2-12.5-MP-0	5000	EN-PC-146-055-3-2-12.5-MP-0	5000	60	49	-50	Figure 6
	2	12.5	Moisture Panel	25	198	EN-PC-146-055-6-2-12.5-MP-25	7100	EN-PC-146-055-4-2-12.5-MP-25	7500	EN-PC-146-055-3-2-12.5-MP-25	7900	Not Tested	53	-25	Figure 4
	2	12.5	Moisture Panel	25	198	EN-PC-146-055-6-2-12.5-MP-25	7100	EN-PC-146-055-4-2-12.5-MP-25	7500	EN-PC-146-055-3-2-12.5-MP-25	7900	Not Tested	53	-50	Figure 8
	2	15	Moisture Panel	Non Insulated	208	EN-PC-146-055-6-2-15-MP-0	5000	EN-PC-146-055-4-2-15-MP-0	5000	EN-PC-146-055-3-2-15-MP-0	5000	30*	50	-25	Figure 2
	2	15	Moisture Panel	Non Insulated	208	EN-PC-146-055-6-2-15-MP-0	5000	EN-PC-146-055-4-2-15-MP-0	5000	EN-PC-146-055-3-2-15-MP-0	5000	30*	50	-50	Figure 6
	2	15	Moisture Panel	25	208	EN-PC-146-055-6-2-15-MP-25	5000	EN-PC-146-055-4-2-15-MP-25	5000	EN-PC-146-055-3-2-15-MP-25	5000	30*	54	-25	Figure 4
	2	15	Moisture Panel	25	208	EN-PC-146-055-6-2-15-MP-25	5000	EN-PC-146-055-4-2-15-MP-25	5000	EN-PC-146-055-3-2-15-MP-25	5000	30*	54	-50	Figure 8

*System performance based on single layer system

1. Maximum height for EN Compliance Systems: The stated maximum height figure is the lower value between maximum cold state height, calculated to limiting deflection of L/240 @ 200 Pascals and the fire state height, as outlined in accordance with BS EN 1364-1 and BS EN 15254-3.
2. Fire resistance period: Tested in accordance with BS EN 1364-1. Fire resistance period is inclusive of fire integrity and fire insulation (EI). Fire resistance performance must be reviewed against Knauf specifications and standard details.
3. Acoustic sound insulation: Tested or assessed in accordance with BS EN ISO 10140-1 and BS EN 10140-2. Important - Acoustic Sound Insulation Performance based on Knauf studs at 600mm centres and non-deflection arrangement. Systems that are fire resistance and / or offering acoustic sound performance must have all outer joints taped and filled in accordance with Knauf recommendations. Systems are tested as imperforate.

EN Compliance Specifications

Knauf Performer - Fire Panel (EN Compliance)



Got a question? Email our Technical Service on technical-uk@knauf.com or call 0800 521050 (option 2)

50mm Stud Solutions

Knauf Stud depth and gauge (mm)	Knauf Plasterboard layers to each side of Knauf Stud (no)	Thickness of Knauf Plasterboard (mm)	Knauf Plasterboard	Knauf Insulation Acoustic Roll - Cavity Insulation (mm)	System width (mm) excluding finishes	System code & Maximum height ¹ (mm) @ 600mm centres	System code & Maximum height ¹ (mm) @ 400mm centres	System code & Maximum height ¹ (mm) @ 300mm centres	Fire resistance period ² (minutes)	Acoustic Sound Insulation ³ (dB Rw)	Deflection allowance (mm)	Deflection head arrangement			
50'C Stud (0.55)	1	12.5	Fire Panel	Non Insulated	77	EN-PC-50-055-6-1-12.5-FP-0	3000	EN-PC-50-055-4-1-12.5-FP-0	3200	EN-PC-50-055-3-1-12.5-FP-0	3400	30	34	-25	Figure 1
	1	12.5	Fire Panel	25	77	EN-PC-50-055-6-1-12.5-FP-25	3000	EN-PC-50-055-4-1-12.5-FP-25	3200	EN-PC-50-055-3-1-12.5-FP-25	3400	30	42	-25	Figure 3
	1	15	Fire Panel	Non Insulated	82	EN-PC-50-055-6-1-15-FP-0	3100	EN-PC-50-055-4-1-15-FP-0	3300	EN-PC-50-055-3-1-15-FP-0	3500	30	36	-25	Figure 1
	1	15	Fire Panel	25	82	EN-PC-50-055-6-1-15-FP-25	3100	EN-PC-50-055-4-1-15-FP-25	3300	EN-PC-50-055-3-1-15-FP-25	3500	Not Tested	42	-25	Figure 3
	2	12.5	Fire Panel	Non Insulated	102	EN-PC-50-055-6-2-12.5-FP-0	3700	EN-PC-50-055-4-2-12.5-FP-0	3800	EN-PC-50-055-3-2-12.5-FP-0	4000	120	42	-25	Figure 13
	2	12.5	Fire Panel	25	102	EN-PC-50-055-6-2-12.5-FP-25	3700	EN-PC-50-055-4-2-12.5-FP-25	3800	EN-PC-50-055-3-2-12.5-FP-25	4000	Not Tested	49	-25	Figure 14
	2	15	Fire Panel	Non Insulated	112	EN-PC-50-055-6-2-15-FP-0	3900	EN-PC-50-055-4-2-15-FP-0	4000	EN-PC-50-055-3-2-15-FP-0	4200	120	45	-25	Figure 13
	2	15	Fire Panel	25	112	EN-PC-50-055-6-2-15-FP-25	3900	EN-PC-50-055-4-2-15-FP-25	4000	EN-PC-50-055-3-2-15-FP-25	4200	Not Tested	51	-25	Figure 14

70mm Stud Solutions

Knauf Stud depth and gauge (mm)	Knauf Plasterboard layers to each side of Knauf Stud (no)	Thickness of Knauf Plasterboard (mm)	Knauf Plasterboard	Knauf Insulation Acoustic Roll - Cavity Insulation (mm)	System width (mm) excluding finishes	System code & Maximum height ¹ (mm) @ 600mm centres	System code & Maximum height ¹ (mm) @ 400mm centres	System code & Maximum height ¹ (mm) @ 300mm centres	Fire resistance period ² (minutes)	Acoustic Sound Insulation ³ (dB Rw)	Deflection allowance (mm)	Deflection head arrangement			
70'C Stud (0.55)	1	12.5	Fire Panel	Non Insulated	97	EN-PC-70-055-6-1-12.5-FP-0	3600	EN-PC-70-055-4-1-12.5-FP-0	3900	EN-PC-70-055-3-1-12.5-FP-0	4200	30	35	-25	Figure 1
	1	12.5	Fire Panel	Non Insulated	97	EN-PC-70-055-6-1-12.5-FP-0	3600	EN-PC-70-055-4-1-12.5-FP-0	3900	EN-PC-70-055-3-1-12.5-FP-0	4000	30	35	-50	Figure 5
	1	12.5	Fire Panel	25	97	EN-PC-70-055-6-1-12.5-FP-25	3600	EN-PC-70-055-4-1-12.5-FP-25	3900	EN-PC-70-055-3-1-12.5-FP-25	4200	30	42	-25	Figure 3
	1	12.5	Fire Panel	25	97	EN-PC-70-055-6-1-12.5-FP-25	3600	EN-PC-70-055-4-1-12.5-FP-25	3900	EN-PC-70-055-3-1-12.5-FP-25	4000	30	42	-50	Figure 7
	1	15	Fire Panel	Non Insulated	102	EN-PC-70-055-6-1-15-FP-0	3000	EN-PC-70-055-4-1-15-FP-0	3000	EN-PC-70-055-3-1-15-FP-0	3000	60	37	-25	Figure 9
	1	15	Fire Panel	Non Insulated	102	EN-PC-70-055-6-1-15-FP-0	3000	EN-PC-70-055-4-1-15-FP-0	3000	EN-PC-70-055-3-1-15-FP-0	3000	60	37	-50	Figure 10
	1	15	Fire Panel	25	102	EN-PC-70-055-6-1-15-FP-25	4000	EN-PC-70-055-4-1-15-FP-25	4300	EN-PC-70-055-3-1-15-FP-25	4500	Not Tested	43	-25	Figure 3
	1	15	Fire Panel	25	102	EN-PC-70-055-6-1-15-FP-25	4000	EN-PC-70-055-4-1-15-FP-25	4300	EN-PC-70-055-3-1-15-FP-25	4500	Not Tested	43	-50	Figure 7
	2	12.5	Fire Panel	Non Insulated	122	EN-PC-70-055-6-2-12.5-FP-0	4500	EN-PC-70-055-4-2-12.5-FP-0	4700	EN-PC-70-055-3-2-12.5-FP-0	4900	120	43	-25	Figure 13
	2	12.5	Fire Panel	Non Insulated	122	EN-PC-70-055-6-2-12.5-FP-0	4500	EN-PC-70-055-4-2-12.5-FP-0	4700	EN-PC-70-055-3-2-12.5-FP-0	4900	120	43	-50	Figure 15
	2	12.5	Fire Panel	25	122	EN-PC-70-055-6-2-12.5-FP-25	4000	EN-PC-70-055-4-2-12.5-FP-25	4000	EN-PC-70-055-3-2-12.5-FP-25	4000	120	52	-25	Figure 14
	2	12.5	Fire Panel	25	122	EN-PC-70-055-6-2-12.5-FP-25	4000	EN-PC-70-055-4-2-12.5-FP-25	4000	EN-PC-70-055-3-2-12.5-FP-25	4000	120	52	-50	Figure 16
	2	15	Fire Panel	Non Insulated	132	EN-PC-70-055-6-2-15-FP-0	4800	EN-PC-70-055-4-2-15-FP-0	5000	EN-PC-70-055-3-2-15-FP-0	5000	120	46	-25	Figure 13
	2	15	Fire Panel	Non Insulated	132	EN-PC-70-055-6-2-15-FP-0	4800	EN-PC-70-055-4-2-15-FP-0	5000	EN-PC-70-055-3-2-15-FP-0	5000	120	46	-50	Figure 15
	2	15	Fire Panel	25	132	EN-PC-70-055-6-2-15-FP-25	4800	EN-PC-70-055-4-2-15-FP-25	5000	EN-PC-70-055-3-2-15-FP-25	5200	Not Tested	54	-25	Figure 14
	2	15	Fire Panel	25	132	EN-PC-70-055-6-2-15-FP-25	4800	EN-PC-70-055-4-2-15-FP-25	5000	EN-PC-70-055-3-2-15-FP-25	5200	Not Tested	54	-50	Figure 16

1. **Maximum height for EN Compliance Systems:** The stated maximum height figure is the lower value between maximum cold state height, calculated to limiting deflection of L/240 @ 200 Pascals and the fire state height, as outlined in accordance with BS EN 1364-1 and BS EN 15254-3.
 2. **Fire resistance period:** Tested in accordance with BS EN 1364-1. Fire resistance period is inclusive of fire integrity and fire insulation (EI). Fire resistance performance must be reviewed against Knauf specifications and standard details.
 3. **Acoustic sound insulation:** Tested or assessed in accordance with BS EN ISO 10140-1 and BS EN 10140-2. Important - Acoustic Sound Insulation Performance based on Knauf studs at 600mm centres and non-deflection arrangement. Systems that are fire resistance and / or offering acoustic sound performance must have all outer joints taped and filled in accordance with Knauf recommendations. Systems are tested as imperforate.

EN Compliance Specifications

Knauf Performer - Fire Panel (EN Compliance)



Got a question? Email our Technical Service on technical-uk@knauf.com or call 0800 521050 (option 2)

92mm Stud Solutions

Knauf Stud depth and gauge (mm)	Knauf Plasterboard layers to each side of Knauf Stud (no)	Thickness of Knauf Plasterboard (mm)	Knauf Plasterboard	Knauf Insulation Acoustic Roll - Cavity Insulation (mm)	System width (mm) excluding finishes	System code & Maximum height ¹ (mm) @ 600mm centres	System code & Maximum height ¹ (mm) @ 400mm centres	System code & Maximum height ¹ (mm) @ 300mm centres	Fire resistance period ² (minutes)	Acoustic Sound Insulation ³ (dB Rw)	Deflection allowance (mm)	Deflection head arrangement			
92'C Stud (0.70)	1	12.5	Fire Panel	Non Insulated	119	EN-PC-92-070-6-1-12.5-FP-0	4900	EN-PC-92-070-4-1-12.5-FP-0	5000	EN-PC-92-070-3-1-12.5-FP-0	5000	30	35	-25	Figure 1
	1	12.5	Fire Panel	Non Insulated	119	EN-PC-92-070-6-1-12.5-FP-0	4000	EN-PC-92-070-4-1-12.5-FP-0	4000	EN-PC-92-070-3-1-12.5-FP-0	4000	30	35	-50	Figure 5
	1	12.5	Fire Panel	25	119	EN-PC-92-070-6-1-12.5-FP-25	4900	EN-PC-92-070-4-1-12.5-FP-25	5000	EN-PC-92-070-3-1-12.5-FP-25	5000	30	42	-25	Figure 3
	1	12.5	Fire Panel	25	119	EN-PC-92-070-6-1-12.5-FP-25	4000	EN-PC-92-070-4-1-12.5-FP-25	4000	EN-PC-92-070-3-1-12.5-FP-25	4000	30	42	-50	Figure 7
	1	15	Fire Panel	Non Insulated	124	EN-PC-92-070-6-1-15-FP-0	3000	EN-PC-92-070-4-1-15-FP-0	3000	EN-PC-92-070-3-1-15-FP-0	3000	60	37	-25	Figure 9
	1	15	Fire Panel	Non Insulated	124	EN-PC-92-070-6-1-15-FP-0	3000	EN-PC-92-070-4-1-15-FP-0	3000	EN-PC-92-070-3-1-15-FP-0	3000	60	37	-50	Figure 10
	1	15	Fire Panel	25	124	EN-PC-92-070-6-1-15-FP-25	5100	EN-PC-92-070-4-1-15-FP-25	5400	EN-PC-92-070-3-1-15-FP-25	5800	Not Tested	43	-25	Figure 3
	1	15	Fire Panel	25	124	EN-PC-92-070-6-1-15-FP-25	5100	EN-PC-92-070-4-1-15-FP-25	5400	EN-PC-92-070-3-1-15-FP-25	5800	Not Tested	43	-50	Figure 7
	2	12.5	Fire Panel	Non Insulated	144	EN-PC-92-070-6-2-12.5-FP-0	5000	EN-PC-92-070-4-2-12.5-FP-0	5000	EN-PC-92-070-3-2-12.5-FP-0	5000	120	43	-25	Figure 13
	2	12.5	Fire Panel	Non Insulated	144	EN-PC-92-070-6-2-12.5-FP-0	5000	EN-PC-92-070-4-2-12.5-FP-0	5000	EN-PC-92-070-3-2-12.5-FP-0	5000	120	43	-50	Figure 15
	2	12.5	Fire Panel	25	144	EN-PC-92-070-6-2-12.5-FP-25	4000	EN-PC-92-070-4-2-12.5-FP-25	4000	EN-PC-92-070-3-2-12.5-FP-25	4000	120	52	-25	Figure 14
	2	12.5	Fire Panel	25	144	EN-PC-92-070-6-2-12.5-FP-25	4000	EN-PC-92-070-4-2-12.5-FP-25	4000	EN-PC-92-070-3-2-12.5-FP-25	4000	120	52	-50	Figure 16
	2	15	Fire Panel	Non Insulated	154	EN-PC-92-070-6-2-15-FP-0	5000	EN-PC-92-070-4-2-15-FP-0	5000	EN-PC-92-070-3-2-15-FP-0	5000	120	46	-25	Figure 13
	2	15	Fire Panel	Non Insulated	154	EN-PC-92-070-6-2-15-FP-0	5000	EN-PC-92-070-4-2-15-FP-0	5000	EN-PC-92-070-3-2-15-FP-0	5000	120	46	-50	Figure 15
	2	15	Fire Panel	25	154	EN-PC-92-070-6-2-15-FP-25	6000	EN-PC-92-070-4-2-15-FP-25	6300	EN-PC-92-070-3-2-15-FP-25	6600	Not Tested	54	-25	Figure 14
	2	15	Fire Panel	25	154	EN-PC-92-070-6-2-15-FP-25	6000	EN-PC-92-070-4-2-15-FP-25	6300	EN-PC-92-070-3-2-15-FP-25	6600	Not Tested	54	-50	Figure 16

146mm Stud Solutions

Knauf Stud depth and gauge (mm)	Knauf Plasterboard layers to each side of Knauf Stud (no)	Thickness of Knauf Plasterboard (mm)	Knauf Plasterboard	Knauf Insulation Acoustic Roll - Cavity Insulation (mm)	System width (mm) excluding finishes	System code & Maximum height ¹ (mm) @ 600mm centres	System code & Maximum height ¹ (mm) @ 400mm centres	System code & Maximum height ¹ (mm) @ 300mm centres	Fire resistance period ² (minutes)	Acoustic Sound Insulation ³ (dB Rw)	Deflection allowance (mm)	Deflection head arrangement			
146'C Stud (0.55)	1	12.5	Fire Panel	Non Insulated	173	EN-PC-146-055-6-1-12.5-FP-0	5000	EN-PC-146-055-4-1-12.5-FP-0	5000	EN-PC-146-055-3-1-12.5-FP-0	5000	30	35	-25	Figure 1
	1	12.5	Fire Panel	Non Insulated	173	EN-PC-146-055-6-1-12.5-FP-0	4000	EN-PC-146-055-4-1-12.5-FP-0	4000	EN-PC-146-055-3-1-12.5-FP-0	4000	30	35	-50	Figure 5
	1	12.5	Fire Panel	25	173	EN-PC-146-055-6-1-12.5-FP-25	5000	EN-PC-146-055-4-1-12.5-FP-25	5000	EN-PC-146-055-3-1-12.5-FP-25	5000	30	42	-25	Figure 3
	1	12.5	Fire Panel	25	173	EN-PC-146-055-6-1-12.5-FP-25	4000	EN-PC-146-055-4-1-12.5-FP-25	4000	EN-PC-146-055-3-1-12.5-FP-25	4000	30	42	-50	Figure 7
	1	15	Fire Panel	Non Insulated	178	EN-PC-146-055-6-1-15-FP-0	3000	EN-PC-146-055-4-1-15-FP-0	3000	EN-PC-146-055-3-1-15-FP-0	3000	60	37	-25	Figure 9
	1	15	Fire Panel	Non Insulated	178	EN-PC-146-055-6-1-15-FP-0	3000	EN-PC-146-055-4-1-15-FP-0	3000	EN-PC-146-055-3-1-15-FP-0	3000	60	37	-50	Figure 10
	1	15	Fire Panel	25	178	EN-PC-146-055-6-1-15-FP-25	6100	EN-PC-146-055-4-1-15-FP-25	6700	EN-PC-146-055-3-1-15-FP-25	7200	Not Tested	43	-25	Figure 3
	1	15	Fire Panel	25	178	EN-PC-146-055-6-1-15-FP-25	6100	EN-PC-146-055-4-1-15-FP-25	6700	EN-PC-146-055-3-1-15-FP-25	7200	Not Tested	43	-50	Figure 7
	2	12.5	Fire Panel	Non Insulated	198	EN-PC-146-055-6-2-12.5-FP-0	5000	EN-PC-146-055-4-2-12.5-FP-0	5000	EN-PC-146-055-3-2-12.5-FP-0	5000	120	49	-25	Figure 13
	2	12.5	Fire Panel	Non Insulated	198	EN-PC-146-055-6-2-12.5-FP-0	5000	EN-PC-146-055-4-2-12.5-FP-0	5000	EN-PC-146-055-3-2-12.5-FP-0	5000	120	49	-50	Figure 15
	2	12.5	Fire Panel	25	198	EN-PC-146-055-6-2-12.5-FP-25	4000	EN-PC-146-055-4-2-12.5-FP-25	4000	EN-PC-146-055-3-2-12.5-FP-25	4000	120	53	-25	Figure 14
	2	12.5	Fire Panel	25	198	EN-PC-146-055-6-2-12.5-FP-25	4000	EN-PC-146-055-4-2-12.5-FP-25	4000	EN-PC-146-055-3-2-12.5-FP-25	4000	120	53	-50	Figure 16
	2	15	Fire Panel	Non Insulated	208	EN-PC-146-055-6-2-15-FP-0	5000	EN-PC-146-055-4-2-15-FP-0	5000	EN-PC-146-055-3-2-15-FP-0	5000	120	50	-25	Figure 13
	2	15	Fire Panel	Non Insulated	208	EN-PC-146-055-6-2-15-FP-0	5000	EN-PC-146-055-4-2-15-FP-0	5000	EN-PC-146-055-3-2-15-FP-0	5000	120	50	-50	Figure 15
	2	15	Fire Panel	25	208	EN-PC-146-055-6-2-15-FP-25	7500	EN-PC-146-055-4-2-15-FP-25	7900	EN-PC-146-055-3-2-15-FP-25	8300	Not Tested	54	-25	Figure 14
	2	15	Fire Panel	25	208	EN-PC-146-055-6-2-15-FP-25	7500	EN-PC-146-055-4-2-15-FP-25	7900	EN-PC-146-055-3-2-15-FP-25	8300	Not Tested	54	-50	Figure 16

1. Maximum height for EN Compliance Systems: The stated maximum height figure is the lower value between maximum cold state height, calculated to limiting deflection of L/240 @ 200 Pascals and the fire state height, as outlined in accordance with BS EN 1364-1 and BS EN 15254-3.
2. Fire resistance period: Tested in accordance with BS EN 1364-1. Fire resistance period is inclusive of fire integrity and fire insulation (EI). Fire resistance performance must be reviewed against Knauf specifications and standard details.
3. Acoustic sound insulation: Tested or assessed in accordance with BS EN ISO 10140-1 and BS EN 10140-2. Important - Acoustic Sound Insulation Performance based on Knauf studs at 600mm centres and non-deflection arrangement. Systems that are fire resistance and / or offering acoustic sound performance must have all outer joints taped and filled in accordance with Knauf recommendations. Systems are tested as imperforate.

EN Compliance Specifications

Knauf Performer - Soundshield Plus (EN Compliance)



Got a question? Email our Technical Service on technical-uk@knauf.com or call 0800 521050 (option 2)

50mm Stud Solutions

Knauf Stud depth and gauge (mm)	Knauf Plasterboard layers to each side of Knauf Stud (no)	Thickness of Knauf Plasterboard (mm)	Knauf Plasterboard	Knauf Insulation Acoustic Roll - Cavity Insulation (mm)	System width (mm) excluding finishes	System code & Maximum height ¹ (mm) @ 600mm centres	System code & Maximum height ¹ (mm) @ 400mm centres	System code & Maximum height ¹ (mm) @ 300mm centres	Fire resistance period ² (minutes)	Acoustic Sound Insulation ³ (dB Rw)	Deflection allowance (mm)	Deflection head arrangement			
50'C Stud (0.55)	1	12.5	Soundshield Plus	Non Insulated	77	EN-PC-50-055-6-1-12.5-SSP-0	3000	EN-PC-50-055-4-1-12.5-SSP-0	3200	EN-PC-50-055-3-1-12.5-SSP-0	3400	30	38	-25	Figure 1
	1	12.5	Soundshield Plus	25	77	EN-PC-50-055-6-1-12.5-SSP-25	3000	EN-PC-50-055-4-1-12.5-SSP-25	3200	EN-PC-50-055-3-1-12.5-SSP-25	3400	30	44	-25	Figure 3
	1	15	Soundshield Plus	Non Insulated	82	EN-PC-50-055-6-1-15-SSP-0	3100	EN-PC-50-055-4-1-15-SSP-0	3300	EN-PC-50-055-3-1-15-SSP-0	3500	30	37	-25	Figure 1
	1	15	Soundshield Plus	25	82	EN-PC-50-055-6-1-15-SSP-25	3100	EN-PC-50-055-4-1-15-SSP-25	3300	EN-PC-50-055-3-1-15-SSP-25	3500	60	42	-25	Figure 11
	2	12.5	Soundshield Plus	Non Insulated	102	EN-PC-50-055-6-2-12.5-SSP-0	3700	EN-PC-50-055-4-2-12.5-SSP-0	3800	EN-PC-50-055-3-2-12.5-SSP-0	4000	60	46	-25	Figure 2
	2	12.5	Soundshield Plus	25	102	EN-PC-50-055-6-2-12.5-SSP-25	3700	EN-PC-50-055-4-2-12.5-SSP-25	3800	EN-PC-50-055-3-2-12.5-SSP-25	4000	60	53	-25	Figure 4
	2	15	Soundshield Plus	Non Insulated	112	EN-PC-50-055-6-2-15-SSP-0	3900	EN-PC-50-055-4-2-15-SSP-0	4000	EN-PC-50-055-3-2-15-SSP-0	4200	120	45	-25	Figure 13
	2	15	Soundshield Plus	25	112	EN-PC-50-055-6-2-15-SSP-25	3900	EN-PC-50-055-4-2-15-SSP-25	4000	EN-PC-50-055-3-2-15-SSP-25	4200	120	52	-25	Figure 14

70mm Stud Solutions

Knauf Stud depth and gauge (mm)	Knauf Plasterboard layers to each side of Knauf Stud (no)	Thickness of Knauf Plasterboard (mm)	Knauf Plasterboard	Knauf Insulation Acoustic Roll - Cavity Insulation (mm)	System width (mm) excluding finishes	System code & Maximum height ¹ (mm) @ 600mm centres	System code & Maximum height ¹ (mm) @ 400mm centres	System code & Maximum height ¹ (mm) @ 300mm centres	Fire resistance period ² (minutes)	Acoustic Sound Insulation ³ (dB Rw)	Deflection allowance (mm)	Deflection head arrangement			
70'C Stud (0.55)	1	12.5	Soundshield Plus	Non Insulated	97	EN-PC-70-055-6-1-12.5-SSP-0	3600	EN-PC-70-055-4-1-12.5-SSP-0	3900	EN-PC-70-055-3-1-12.5-SSP-0	4200	30	38	-25	Figure 1
	1	12.5	Soundshield Plus	Non Insulated	97	EN-PC-70-055-6-1-12.5-SSP-0	3600	EN-PC-70-055-4-1-12.5-SSP-0	3900	EN-PC-70-055-3-1-12.5-SSP-0	4000	30	38	-50	Figure 5
	1	12.5	Soundshield Plus	25	97	EN-PC-70-055-6-1-12.5-SSP-25	3600	EN-PC-70-055-4-1-12.5-SSP-25	3900	EN-PC-70-055-3-1-12.5-SSP-25	4200	30	45	-25	Figure 3
	1	12.5	Soundshield Plus	25	97	EN-PC-70-055-6-1-12.5-SSP-25	3600	EN-PC-70-055-4-1-12.5-SSP-25	3900	EN-PC-70-055-3-1-12.5-SSP-25	4000	30	45	-50	Figure 7
	1	15	Soundshield Plus	Non Insulated	102	EN-PC-70-055-6-1-15-SSP-0	4000	EN-PC-70-055-4-1-15-SSP-0	4300	EN-PC-70-055-3-1-15-SSP-0	4500	30	40	-25	Figure 1
	1	15	Soundshield Plus	Non Insulated	102	EN-PC-70-055-6-1-15-SSP-0	4000	EN-PC-70-055-4-1-15-SSP-0	4300	EN-PC-70-055-3-1-15-SSP-0	4500	30	40	-50	Figure 5
	1	15	Soundshield Plus	25	102	EN-PC-70-055-6-1-15-SSP-25	4000	EN-PC-70-055-4-1-15-SSP-25	4300	EN-PC-70-055-3-1-15-SSP-25	4500	60	47	-25	Figure 11
	1	15	Soundshield Plus	25	102	EN-PC-70-055-6-1-15-SSP-25	4000	EN-PC-70-055-4-1-15-SSP-25	4000	EN-PC-70-055-3-1-15-SSP-25	4000	60	47	-50	Figure 12
	2	12.5	Soundshield Plus	Non Insulated	122	EN-PC-70-055-6-2-12.5-SSP-0	4500	EN-PC-70-055-4-2-12.5-SSP-0	4700	EN-PC-70-055-3-2-12.5-SSP-0	4900	60	48	-25	Figure 2
	2	12.5	Soundshield Plus	Non Insulated	122	EN-PC-70-055-6-2-12.5-SSP-0	4500	EN-PC-70-055-4-2-12.5-SSP-0	4700	EN-PC-70-055-3-2-12.5-SSP-0	4900	60	48	-50	Figure 6
	2	12.5	Soundshield Plus	25	122	EN-PC-70-055-6-2-12.5-SSP-25	4500	EN-PC-70-055-4-2-12.5-SSP-25	4700	EN-PC-70-055-3-2-12.5-SSP-25	4900	60	53	-25	Figure 4
	2	12.5	Soundshield Plus	25	122	EN-PC-70-055-6-2-12.5-SSP-25	4000	EN-PC-70-055-4-2-12.5-SSP-25	4000	EN-PC-70-055-3-2-12.5-SSP-25	4000	60	53	-50	Figure 8
	2	15	Soundshield Plus	Non Insulated	132	EN-PC-70-055-6-2-15-SSP-0	4800	EN-PC-70-055-4-2-15-SSP-0	5000	EN-PC-70-055-3-2-15-SSP-0	5000	120	49	-25	Figure 13
	2	15	Soundshield Plus	Non Insulated	132	EN-PC-70-055-6-2-15-SSP-0	4800	EN-PC-70-055-4-2-15-SSP-0	5000	EN-PC-70-055-3-2-15-SSP-0	5000	120	49	-50	Figure 15
	2	15	Soundshield Plus	25	132	EN-PC-70-055-6-2-15-SSP-25	4800	EN-PC-70-055-4-2-15-SSP-25	5000	EN-PC-70-055-3-2-15-SSP-25	5000	120	55	-25	Figure 14
	2	15	Soundshield Plus	25	132	EN-PC-70-055-6-2-15-SSP-25	4800	EN-PC-70-055-4-2-15-SSP-25	5000	EN-PC-70-055-3-2-15-SSP-25	5000	120	55	-50	Figure 16

1. Maximum height for EN Compliance Systems: The stated maximum height figure is the lower value between maximum cold state height, calculated to limiting deflection of L/240 @ 200 Pascals and the fire state height, as outlined in accordance with BS EN 1364-1 and BS EN 15254-3.
2. Fire resistance period: Tested in accordance with BS EN 1364-1. Fire resistance period is inclusive of fire integrity and fire insulation (EI). Fire resistance performance must be reviewed against Knauf specifications and standard details.
3. Acoustic sound insulation: Tested or assessed in accordance with BS EN ISO 10140-1 and BS EN 10140-2. Important - Acoustic Sound Insulation Performance based on Knauf studs at 600mm centres and non-deflection arrangement. Systems that are fire resistance and / or offering acoustic sound performance must have all outer joints taped and filled in accordance with Knauf recommendations. Systems are tested as imperforate.

EN Compliance Specifications

Knauf Performer - Soundshield Plus (EN Compliance)



Got a question? Email our Technical Service on technical-uk@knauf.com or call 0800 521050 (option 2)

92mm Stud Solutions

Knauf Stud depth and gauge (mm)	Knauf Plasterboard layers to each side of Knauf Stud (no)	Thickness of Knauf Plasterboard (mm)	Knauf Plasterboard	Knauf Insulation Acoustic Roll - Cavity Insulation (mm)	System width (mm) excluding finishes	System code & Maximum height ¹ (mm) @ 600mm centres	System code & Maximum height ¹ (mm) @ 400mm centres	System code & Maximum height ¹ (mm) @ 300mm centres	Fire resistance period ² (minutes)	Acoustic Sound Insulation ³ (dB Rw)	Deflection allowance (mm)	Deflection head arrangement			
92 'C' Stud (0.70)	1	12.5	Soundshield Plus	Non Insulated	119	EN-PC-92-070-6-1-12.5-SSP-0	4900	EN-PC-92-070-4-1-12.5-SSP-0	5000	EN-PC-92-070-3-1-12.5-SSP-0	5000	30	38	-25	Figure 1
	1	12.5	Soundshield Plus	Non Insulated	119	EN-PC-92-070-6-1-12.5-SSP-0	4000	EN-PC-92-070-4-1-12.5-SSP-0	4000	EN-PC-92-070-3-1-12.5-SSP-0	4000	30	38	-50	Figure 5
	1	12.5	Soundshield Plus	25	119	EN-PC-92-070-6-1-12.5-SSP-25	4900	EN-PC-92-070-4-1-12.5-SSP-25	5000	EN-PC-92-070-3-1-12.5-SSP-25	5000	30	45	-25	Figure 3
	1	12.5	Soundshield Plus	25	119	EN-PC-92-070-6-1-12.5-SSP-25	4000	EN-PC-92-070-4-1-12.5-SSP-25	4000	EN-PC-92-070-3-1-12.5-SSP-25	4000	30	45	-50	Figure 7
	1	15	Soundshield Plus	Non Insulated	124	EN-PC-92-070-6-1-15-SSP-0	5000	EN-PC-92-070-4-1-15-SSP-0	5000	EN-PC-92-070-3-1-15-SSP-0	5000	30	40	-25	Figure 1
	1	15	Soundshield Plus	Non Insulated	124	EN-PC-92-070-6-1-15-SSP-0	5000	EN-PC-92-070-4-1-15-SSP-0	5000	EN-PC-92-070-3-1-15-SSP-0	5000	30	40	-50	Figure 5
	1	15	Soundshield Plus	25	124	EN-PC-92-070-6-1-15-SSP-25	5000	EN-PC-92-070-4-1-15-SSP-25	5000	EN-PC-92-070-3-1-15-SSP-25	5000	60	47	-25	Figure 11
	1	15	Soundshield Plus	25	124	EN-PC-92-070-6-1-15-SSP-25	4000	EN-PC-92-070-4-1-15-SSP-25	4000	EN-PC-92-070-3-1-15-SSP-25	4000	60	47	-50	Figure 12
	2	12.5	Soundshield Plus	Non Insulated	144	EN-PC-92-070-6-2-12.5-SSP-0	5000	EN-PC-92-070-4-2-12.5-SSP-0	5000	EN-PC-92-070-3-2-12.5-SSP-0	5000	60	48	-25	Figure 2
	2	12.5	Soundshield Plus	Non Insulated	144	EN-PC-92-070-6-2-12.5-SSP-0	5000	EN-PC-92-070-4-2-12.5-SSP-0	5000	EN-PC-92-070-3-2-12.5-SSP-0	5000	60	48	-50	Figure 6
	2	12.5	Soundshield Plus	25	144	EN-PC-92-070-6-2-12.5-SSP-25	5000	EN-PC-92-070-4-2-12.5-SSP-25	5000	EN-PC-92-070-3-2-12.5-SSP-25	5000	60	53	-25	Figure 4
	2	12.5	Soundshield Plus	25	144	EN-PC-92-070-6-2-12.5-SSP-25	4000	EN-PC-92-070-4-2-12.5-SSP-25	4000	EN-PC-92-070-3-2-12.5-SSP-25	4000	60	53	-50	Figure 8
	2	15	Soundshield Plus	Non Insulated	154	EN-PC-92-070-6-2-15-SSP-0	5000	EN-PC-92-070-4-2-15-SSP-0	5000	EN-PC-92-070-3-2-15-SSP-0	5000	120	49	-25	Figure 13
	2	15	Soundshield Plus	Non Insulated	154	EN-PC-92-070-6-2-15-SSP-0	5000	EN-PC-92-070-4-2-15-SSP-0	5000	EN-PC-92-070-3-2-15-SSP-0	5000	120	49	-50	Figure 15
	2	15	Soundshield Plus	25	154	EN-PC-92-070-6-2-15-SSP-25	5000	EN-PC-92-070-4-2-15-SSP-25	5000	EN-PC-92-070-3-2-15-SSP-25	5000	120	55	-25	Figure 14
	2	15	Soundshield Plus	25	154	EN-PC-92-070-6-2-15-SSP-25	5000	EN-PC-92-070-4-2-15-SSP-25	5000	EN-PC-92-070-3-2-15-SSP-25	5000	120	55	-50	Figure 16

146mm Stud Solutions

Knauf Stud depth and gauge (mm)	Knauf Plasterboard layers to each side of Knauf Stud (no)	Thickness of Knauf Plasterboard (mm)	Knauf Plasterboard	Knauf Insulation Acoustic Roll - Cavity Insulation (mm)	System width (mm) excluding finishes	System code & Maximum height ¹ (mm) @ 600mm centres	System code & Maximum height ¹ (mm) @ 400mm centres	System code & Maximum height ¹ (mm) @ 300mm centres	Fire resistance period ² (minutes)	Acoustic Sound Insulation ³ (dB Rw)	Deflection allowance (mm)	Deflection head arrangement			
146 'C' Stud (0.55)	1	12.5	Soundshield Plus	Non Insulated	173	EN-PC-146-055-6-1-12.5-SSP-0	5000	EN-PC-146-055-4-1-12.5-SSP-0	5000	EN-PC-146-055-3-1-12.5-SSP-0	5000	30	38	-25	Figure 1
	1	12.5	Soundshield Plus	Non Insulated	173	EN-PC-146-055-6-1-12.5-SSP-0	4000	EN-PC-146-055-4-1-12.5-SSP-0	4000	EN-PC-146-055-3-1-12.5-SSP-0	4000	30	38	-50	Figure 5
	1	12.5	Soundshield Plus	25	173	EN-PC-146-055-6-1-12.5-SSP-25	5000	EN-PC-146-055-4-1-12.5-SSP-25	5000	EN-PC-146-055-3-1-12.5-SSP-25	5000	30	45	-25	Figure 3
	1	12.5	Soundshield Plus	25	173	EN-PC-146-055-6-1-12.5-SSP-25	4000	EN-PC-146-055-4-1-12.5-SSP-25	4000	EN-PC-146-055-3-1-12.5-SSP-25	4000	30	45	-50	Figure 7
	1	15	Soundshield Plus	Non Insulated	178	EN-PC-146-055-6-1-15-SSP-0	5000	EN-PC-146-055-4-1-15-SSP-0	5000	EN-PC-146-055-3-1-15-SSP-0	5000	30	44	-25	Figure 1
	1	15	Soundshield Plus	Non Insulated	178	EN-PC-146-055-6-1-15-SSP-0	5000	EN-PC-146-055-4-1-15-SSP-0	5000	EN-PC-146-055-3-1-15-SSP-0	5000	30	44	-50	Figure 5
	1	15	Soundshield Plus	25	178	EN-PC-146-055-6-1-15-SSP-25	5000	EN-PC-146-055-4-1-15-SSP-25	5000	EN-PC-146-055-3-1-15-SSP-25	5000	60	47	-25	Figure 11
	1	15	Soundshield Plus	25	178	EN-PC-146-055-6-1-15-SSP-25	4000	EN-PC-146-055-4-1-15-SSP-25	4000	EN-PC-146-055-3-1-15-SSP-25	4000	60	47	-50	Figure 12
	2	12.5	Soundshield Plus	Non Insulated	198	EN-PC-146-055-6-2-12.5-SSP-0	5000	EN-PC-146-055-4-2-12.5-SSP-0	5000	EN-PC-146-055-3-2-12.5-SSP-0	5000	60	49	-25	Figure 2
	2	12.5	Soundshield Plus	Non Insulated	198	EN-PC-146-055-6-2-12.5-SSP-0	5000	EN-PC-146-055-4-2-12.5-SSP-0	5000	EN-PC-146-055-3-2-12.5-SSP-0	5000	60	49	-50	Figure 6
	2	12.5	Soundshield Plus	25	198	EN-PC-146-055-6-2-12.5-SSP-25	5000	EN-PC-146-055-4-2-12.5-SSP-25	5000	EN-PC-146-055-3-2-12.5-SSP-25	5000	60	53	-25	Figure 4
	2	12.5	Soundshield Plus	25	198	EN-PC-146-055-6-2-12.5-SSP-25	4000	EN-PC-146-055-4-2-12.5-SSP-25	4000	EN-PC-146-055-3-2-12.5-SSP-25	4000	60	53	-50	Figure 8
	2	15	Soundshield Plus	Non Insulated	208	EN-PC-146-055-6-2-15-SSP-0	5000	EN-PC-146-055-4-2-15-SSP-0	5000	EN-PC-146-055-3-2-15-SSP-0	5000	120	52	-25	Figure 13
	2	15	Soundshield Plus	Non Insulated	208	EN-PC-146-055-6-2-15-SSP-0	5000	EN-PC-146-055-4-2-15-SSP-0	5000	EN-PC-146-055-3-2-15-SSP-0	5000	120	52	-50	Figure 15
	2	15	Soundshield Plus	25	208	EN-PC-146-055-6-2-15-SSP-25	5000	EN-PC-146-055-4-2-15-SSP-25	5000	EN-PC-146-055-3-2-15-SSP-25	5000	120	55	-25	Figure 14
	2	15	Soundshield Plus	25	208	EN-PC-146-055-6-2-15-SSP-25	5000	EN-PC-146-055-4-2-15-SSP-25	5000	EN-PC-146-055-3-2-15-SSP-25	5000	120	55	-50	Figure 16

1. **Maximum height for EN Compliance Systems:** The stated maximum height figure is the lower value between maximum cold state height, calculated to limiting deflection of L/240 @ 200 Pascals and the fire state height, as outlined in accordance with BS EN 1364-1 and BS EN 15254-3.
 2. **Fire resistance period:** Tested in accordance with BS EN 1364-1. Fire resistance period is inclusive of fire integrity and fire insulation (EI). Fire resistance performance must be reviewed against Knauf specifications and standard details.
 3. **Acoustic sound insulation:** Tested or assessed in accordance with BS EN ISO 10140-1 and BS EN 10140-2. Important - Acoustic Sound Insulation Performance based on Knauf studs at 600mm centres and non-deflection arrangement. Systems that are fire resistance and / or offering acoustic sound performance must have all outer joints taped and filled in accordance with Knauf recommendations. Systems are tested as imperforate.

EN Compliance Specifications

Knauf Performer - Performance Plus (EN Compliance)



Got a question? Email our Technical Service on technical-uk@knauf.com or call 0800 521050 (option 2)

50mm Stud Solutions

Knauf Stud depth and gauge (mm)	Knauf Plasterboard layers to each side of Knauf Stud (no)	Thickness of Knauf Plasterboard (mm)	Knauf Plasterboard	Knauf Insulation Acoustic Roll - Cavity Insulation (mm)	System width (mm) excluding finishes	System code & Maximum height ¹ (mm) @ 600mm centres	System code & Maximum height ¹ (mm) @ 400mm centres	System code & Maximum height ¹ (mm) @ 300mm centres	Fire resistance period ² (minutes)	Acoustic Sound Insulation ³ (dB Rw)	Deflection allowance (mm)	Deflection head arrangement			
50 'C' Stud (0.55)	1	12.5	Performance Plus	Non Insulated	77	EN-PC-50-055-6-1-12.5-PP-0	3000	EN-PC-50-055-4-1-12.5-PP-0	3200	EN-PC-50-055-3-1-12.5-PP-0	3400	30	38	-25	Figure 1
	1	12.5	Performance Plus	25	77	EN-PC-50-055-6-1-12.5-PP-25	3000	EN-PC-50-055-4-1-12.5-PP-25	3200	EN-PC-50-055-3-1-12.5-PP-25	3400	30	44	-25	Figure 3
	1	15	Performance Plus	Non Insulated	82	EN-PC-50-055-6-1-15-PP-0	3100	EN-PC-50-055-4-1-15-PP-0	3300	EN-PC-50-055-3-1-15-PP-0	3500	30	37	-25	Figure 1
	1	15	Performance Plus	25	82	EN-PC-50-055-6-1-15-PP-25	3100	EN-PC-50-055-4-1-15-PP-25	3300	EN-PC-50-055-3-1-15-PP-25	3500	Not Tested	42	-25	Figure 3
	2	12.5	Performance Plus	Non Insulated	102	EN-PC-50-055-6-2-12.5-PP-0	3700	EN-PC-50-055-4-2-12.5-PP-0	3800	EN-PC-50-055-3-2-12.5-PP-0	4000	120	46	-25	Figure 13
	2	12.5	Performance Plus	25	102	EN-PC-50-055-6-2-12.5-PP-25	3700	EN-PC-50-055-4-2-12.5-PP-25	3800	EN-PC-50-055-3-2-12.5-PP-25	4000	Not Tested	53	-25	Figure 14
	2	15	Performance Plus	Non Insulated	112	EN-PC-50-055-6-2-15-PP-0	3900	EN-PC-50-055-4-2-15-PP-0	4000	EN-PC-50-055-3-2-15-PP-0	4200	120	45	-25	Figure 13
	2	15	Performance Plus	25	112	EN-PC-50-055-6-2-15-PP-25	3900	EN-PC-50-055-4-2-15-PP-25	4000	EN-PC-50-055-3-2-15-PP-25	4200	Not Tested	52	-25	Figure 14

70mm Stud Solutions

Knauf Stud depth and gauge (mm)	Knauf Plasterboard layers to each side of Knauf Stud (no)	Thickness of Knauf Plasterboard (mm)	Knauf Plasterboard	Knauf Insulation Acoustic Roll - Cavity Insulation (mm)	System width (mm) excluding finishes	System code & Maximum height ¹ (mm) @ 600mm centres	System code & Maximum height ¹ (mm) @ 400mm centres	System code & Maximum height ¹ (mm) @ 300mm centres	Fire resistance period ² (minutes)	Acoustic Sound Insulation ³ (dB Rw)	Deflection allowance (mm)	Deflection head arrangement			
70 'C' Stud (0.55)	1	12.5	Performance Plus	Non Insulated	97	EN-PC-70-055-6-1-12.5-PP-0	3600	EN-PC-70-055-4-1-12.5-PP-0	3900	EN-PC-70-055-3-1-12.5-PP-0	4200	30	38	-25	Figure 1
	1	12.5	Performance Plus	Non Insulated	97	EN-PC-70-055-6-1-12.5-PP-0	3600	EN-PC-70-055-4-1-12.5-PP-0	3900	EN-PC-70-055-3-1-12.5-PP-0	4000	30	38	-50	Figure 5
	1	12.5	Performance Plus	25	97	EN-PC-70-055-6-1-12.5-PP-25	3600	EN-PC-70-055-4-1-12.5-PP-25	3900	EN-PC-70-055-3-1-12.5-PP-25	4200	30	45	-25	Figure 3
	1	12.5	Performance Plus	25	97	EN-PC-70-055-6-1-12.5-PP-25	3600	EN-PC-70-055-4-1-12.5-PP-25	3900	EN-PC-70-055-3-1-12.5-PP-25	4000	30	45	-50	Figure 7
	1	15	Performance Plus	Non Insulated	102	EN-PC-70-055-6-1-15-PP-0	4000	EN-PC-70-055-4-1-15-PP-0	4000	EN-PC-70-055-3-1-15-PP-0	4000	60	40	-25	Figure 9
	1	15	Performance Plus	Non Insulated	102	EN-PC-70-055-6-1-15-PP-0	4000	EN-PC-70-055-4-1-15-PP-0	4000	EN-PC-70-055-3-1-15-PP-0	4000	60	40	-50	Figure 10
	1	15	Performance Plus	25	102	EN-PC-70-055-6-1-15-PP-25	4000	EN-PC-70-055-4-1-15-PP-25	4300	EN-PC-70-055-3-1-15-PP-25	4500	60	45	-25	Figure 11
	1	15	Performance Plus	25	102	EN-PC-70-055-6-1-15-PP-25	4000	EN-PC-70-055-4-1-15-PP-25	4000	EN-PC-70-055-3-1-15-PP-25	4000	60	45	-50	Figure 12
	2	12.5	Performance Plus	Non Insulated	122	EN-PC-70-055-6-2-12.5-PP-0	4000	EN-PC-70-055-4-2-12.5-PP-0	4000	EN-PC-70-055-3-2-12.5-PP-0	4000	120	48	-25	Figure 13
	2	12.5	Performance Plus	Non Insulated	122	EN-PC-70-055-6-2-12.5-PP-0	4000	EN-PC-70-055-4-2-12.5-PP-0	4000	EN-PC-70-055-3-2-12.5-PP-0	4000	120	48	-50	Figure 15
	2	12.5	Performance Plus	25	122	EN-PC-70-055-6-2-12.5-PP-25	4000	EN-PC-70-055-4-2-12.5-PP-25	4000	EN-PC-70-055-3-2-12.5-PP-25	4000	120	53	-25	Figure 14
	2	12.5	Performance Plus	25	122	EN-PC-70-055-6-2-12.5-PP-25	4000	EN-PC-70-055-4-2-12.5-PP-25	4000	EN-PC-70-055-3-2-12.5-PP-25	4000	120	53	-50	Figure 16
	2	15	Performance Plus	Non Insulated	132	EN-PC-70-055-6-2-15-PP-0	4800	EN-PC-70-055-4-2-15-PP-0	5000	EN-PC-70-055-3-2-15-PP-0	5000	120	48	-25	Figure 13
	2	15	Performance Plus	Non Insulated	132	EN-PC-70-055-6-2-15-PP-0	4800	EN-PC-70-055-4-2-15-PP-0	5000	EN-PC-70-055-3-2-15-PP-0	5000	120	48	-50	Figure 15
	2	15	Performance Plus	25	132	EN-PC-70-055-6-2-15-PP-25	4800	EN-PC-70-055-4-2-15-PP-25	5000	EN-PC-70-055-3-2-15-PP-25	5000	60*	54	-25	Figure 14
	2	15	Performance Plus	25	132	EN-PC-70-055-6-2-15-PP-25	4000	EN-PC-70-055-4-2-15-PP-25	4000	EN-PC-70-055-3-2-15-PP-25	4000	60*	54	-50	Figure 16

*System performance based on single layer system

1. Maximum height for EN Compliance Systems: The stated maximum height figure is the lower value between maximum cold state height, calculated to limiting deflection of L/240 @ 200 Pascals and the fire state height, as outlined in accordance with BS EN 1364-1 and BS EN 15254-3.
2. Fire resistance period: Tested in accordance with BS EN 1364-1. Fire resistance period is inclusive of fire integrity and fire insulation (EI). Fire resistance performance must be reviewed against Knauf specifications and standard details.
3. Acoustic sound insulation: Tested or assessed in accordance with BS EN ISO 10140-1 and BS EN 10140-2. Important - Acoustic Sound Insulation Performance based on Knauf studs at 600mm centres and non-deflection arrangement. Systems that are fire resistance and / or offering acoustic sound performance must have all outer joints taped and filled in accordance with Knauf recommendations. Systems are tested as imperforate.

EN Compliance Specifications

Knauf Performer - Performance Plus (EN Compliance)



Got a question? Email our Technical Service on technical-uk@knauf.com or call 0800 521050 (option 2)

92mm Stud Solutions

Knauf Stud depth and gauge (mm)	Knauf Plasterboard layers to each side of Knauf Stud (no)	Thickness of Knauf Plasterboard (mm)	Knauf Plasterboard	Knauf Insulation Acoustic Roll - Cavity Insulation (mm)	System width (mm) excluding finishes	System code & Maximum height ¹ (mm) @ 600mm centres	System code & Maximum height ¹ (mm) @ 400mm centres	System code & Maximum height ¹ (mm) @ 300mm centres	Fire resistance period ² (minutes)	Acoustic Sound Insulation ³ (dB Rw)	Deflection allowance (mm)	Deflection head arrangement			
92'C Stud (0.70)	1	12.5	Performance Plus	Non Insulated	119	EN-PC-92-070-6-1-12.5-PP-0	4900	EN-PC-92-070-4-1-12.5-PP-0	5000	EN-PC-92-070-3-1-12.5-PP-0	5000	30	38	-25	Figure 1
	1	12.5	Performance Plus	Non Insulated	119	EN-PC-92-070-6-1-12.5-PP-0	4000	EN-PC-92-070-4-1-12.5-PP-0	4000	EN-PC-92-070-3-1-12.5-PP-0	4000	30	38	-50	Figure 5
	1	12.5	Performance Plus	25	119	EN-PC-92-070-6-1-12.5-PP-25	4900	EN-PC-92-070-4-1-12.5-PP-25	5000	EN-PC-92-070-3-1-12.5-PP-25	5000	30	45	-25	Figure 3
	1	12.5	Performance Plus	25	119	EN-PC-92-070-6-1-12.5-PP-25	4000	EN-PC-92-070-4-1-12.5-PP-25	4000	EN-PC-92-070-3-1-12.5-PP-25	4000	30	45	-50	Figure 7
	1	15	Performance Plus	Non Insulated	124	EN-PC-92-070-6-1-15-PP-0	4000	EN-PC-92-070-4-1-15-PP-0	4000	EN-PC-92-070-3-1-15-PP-0	4000	60	40	-25	Figure 9
	1	15	Performance Plus	Non Insulated	124	EN-PC-92-070-6-1-15-PP-0	4000	EN-PC-92-070-4-1-15-PP-0	4300	EN-PC-92-070-3-1-15-PP-0	4500	60	40	-50	Figure 10
	1	15	Performance Plus	25	124	EN-PC-92-070-6-1-15-PP-25	5000	EN-PC-92-070-4-1-15-PP-25	5000	EN-PC-92-070-3-1-15-PP-25	5000	60	47	-25	Figure 11
	1	15	Performance Plus	25	124	EN-PC-92-070-6-1-15-PP-25	4000	EN-PC-92-070-4-1-15-PP-25	4000	EN-PC-92-070-3-1-15-PP-25	4000	60	47	-50	Figure 12
	2	12.5	Performance Plus	Non Insulated	144	EN-PC-92-070-6-2-12.5-PP-0	4000	EN-PC-92-070-4-2-12.5-PP-0	4000	EN-PC-92-070-3-2-12.5-PP-0	4000	120	48	-25	Figure 13
	2	12.5	Performance Plus	Non Insulated	144	EN-PC-92-070-6-2-12.5-PP-0	4000	EN-PC-92-070-4-2-12.5-PP-0	4000	EN-PC-92-070-3-2-12.5-PP-0	4000	120	48	-50	Figure 15
	2	12.5	Performance Plus	25	144	EN-PC-92-070-6-2-12.5-PP-25	4000	EN-PC-92-070-4-2-12.5-PP-25	4000	EN-PC-92-070-3-2-12.5-PP-25	4000	120	53	-25	Figure 14
	2	12.5	Performance Plus	25	144	EN-PC-92-070-6-2-12.5-PP-25	4000	EN-PC-92-070-4-2-12.5-PP-25	4000	EN-PC-92-070-3-2-12.5-PP-25	4000	120	53	-50	Figure 16
	2	15	Performance Plus	Non Insulated	154	EN-PC-92-070-6-2-15-PP-0	5000	EN-PC-92-070-4-2-15-PP-0	5000	EN-PC-92-070-3-2-15-PP-0	5000	120	48	-25	Figure 13
	2	15	Performance Plus	Non Insulated	154	EN-PC-92-070-6-2-15-PP-0	5000	EN-PC-92-070-4-2-15-PP-0	5000	EN-PC-92-070-3-2-15-PP-0	5000	120	48	-50	Figure 15
	2	15	Performance Plus	25	154	EN-PC-92-070-6-2-15-PP-25	5000	EN-PC-92-070-4-2-15-PP-25	5000	EN-PC-92-070-3-2-15-PP-25	5000	60*	54	-25	Figure 14
	2	15	Performance Plus	25	154	EN-PC-92-070-6-2-15-PP-25	4000	EN-PC-92-070-4-2-15-PP-25	4000	EN-PC-92-070-3-2-15-PP-25	4000	60*	54	-50	Figure 16

146mm Stud Solutions

Knauf Stud depth and gauge (mm)	Knauf Plasterboard layers to each side of Knauf Stud (no)	Thickness of Knauf Plasterboard (mm)	Knauf Plasterboard	Knauf Insulation Acoustic Roll - Cavity Insulation (mm)	System width (mm) excluding finishes	System code & Maximum height ¹ (mm) @ 600mm centres	System code & Maximum height ¹ (mm) @ 400mm centres	System code & Maximum height ¹ (mm) @ 300mm centres	Fire resistance period ² (minutes)	Acoustic Sound Insulation ³ (dB Rw)	Deflection allowance (mm)	Deflection head arrangement			
146'C Stud (0.55)	1	12.5	Performance Plus	Non Insulated	173	EN-PC-146-055-6-1-12.5-PP-0	5000	EN-PC-146-055-4-1-12.5-PP-0	5000	EN-PC-146-055-3-1-12.5-PP-0	5000	30	38	-25	Figure 1
	1	12.5	Performance Plus	Non Insulated	173	EN-PC-146-055-6-1-12.5-PP-0	4000	EN-PC-146-055-4-1-12.5-PP-0	4000	EN-PC-146-055-3-1-12.5-PP-0	4000	30	38	-50	Figure 5
	1	12.5	Performance Plus	25	173	EN-PC-146-055-6-1-12.5-PP-25	5000	EN-PC-146-055-4-1-12.5-PP-25	5000	EN-PC-146-055-3-1-12.5-PP-25	5000	30	45	-25	Figure 3
	1	12.5	Performance Plus	25	173	EN-PC-146-055-6-1-12.5-PP-25	4000	EN-PC-146-055-4-1-12.5-PP-25	4000	EN-PC-146-055-3-1-12.5-PP-25	4000	30	45	-50	Figure 7
	1	15	Performance Plus	Non Insulated	178	EN-PC-146-055-6-1-15-PP-0	4000	EN-PC-146-055-4-1-15-PP-0	4000	EN-PC-146-055-3-1-15-PP-0	4000	60	44	-25	Figure 9
	1	15	Performance Plus	Non Insulated	178	EN-PC-146-055-6-1-15-PP-0	4000	EN-PC-146-055-4-1-15-PP-0	4300	EN-PC-146-055-3-1-15-PP-0	4500	60	44	-50	Figure 10
	1	15	Performance Plus	25	178	EN-PC-146-055-6-1-15-PP-25	5000	EN-PC-146-055-4-1-15-PP-25	5000	EN-PC-146-055-3-1-15-PP-25	5000	60	47	-25	Figure 11
	1	15	Performance Plus	25	178	EN-PC-146-055-6-1-15-PP-25	4000	EN-PC-146-055-4-1-15-PP-25	4000	EN-PC-146-055-3-1-15-PP-25	4000	60	47	-50	Figure 12
	2	12.5	Performance Plus	Non Insulated	198	EN-PC-146-055-6-2-12.5-PP-0	4000	EN-PC-146-055-4-2-12.5-PP-0	4000	EN-PC-146-055-3-2-12.5-PP-0	4000	120	48	-25	Figure 13
	2	12.5	Performance Plus	Non Insulated	198	EN-PC-146-055-6-2-12.5-PP-0	4000	EN-PC-146-055-4-2-12.5-PP-0	4000	EN-PC-146-055-3-2-12.5-PP-0	4000	120	48	-50	Figure 15
	2	12.5	Performance Plus	25	198	EN-PC-146-055-6-2-12.5-PP-25	4000	EN-PC-146-055-4-2-12.5-PP-25	4000	EN-PC-146-055-3-2-12.5-PP-25	4000	120	53	-25	Figure 14
	2	12.5	Performance Plus	25	198	EN-PC-146-055-6-2-12.5-PP-25	4000	EN-PC-146-055-4-2-12.5-PP-25	4000	EN-PC-146-055-3-2-12.5-PP-25	4000	120	53	-50	Figure 16
	2	15	Performance Plus	Non Insulated	208	EN-PC-146-055-6-2-15-PP-0	5000	EN-PC-146-055-4-2-15-PP-0	5000	EN-PC-146-055-3-2-15-PP-0	5000	120	52	-25	Figure 13
	2	15	Performance Plus	Non Insulated	208	EN-PC-146-055-6-2-15-PP-0	5000	EN-PC-146-055-4-2-15-PP-0	5000	EN-PC-146-055-3-2-15-PP-0	5000	120	52	-50	Figure 15
	2	15	Performance Plus	25	208	EN-PC-146-055-6-2-15-PP-25	5000	EN-PC-146-055-4-2-15-PP-25	5000	EN-PC-146-055-3-2-15-PP-25	5000	60	54	-25	Figure 14
	2	15	Performance Plus	25	208	EN-PC-146-055-6-2-15-PP-25	4000	EN-PC-146-055-4-2-15-PP-25	4000	EN-PC-146-055-3-2-15-PP-25	4000	60	54	-50	Figure 16

*System performance based on single layer system

1. Maximum height for EN Compliance Systems: The stated maximum height figure is the lower value between maximum cold state height, calculated to limiting deflection of L/240 @ 200 Pascals and the fire state height, as outlined in accordance with BS EN 1364-1 and BS EN 15254-3.
2. Fire resistance period: Tested in accordance with BS EN 1364-1. Fire resistance period is inclusive of fire integrity and fire insulation (EI). Fire resistance performance must be reviewed against Knauf specifications and standard details.
3. Acoustic sound insulation: Tested or assessed in accordance with BS EN ISO 10140-1 and BS EN 10140-2. Important - Acoustic Sound Insulation Performance based on Knauf studs at 600mm centres and non-deflection arrangement. Systems that are fire resistance and / or offering acoustic sound performance must have all outer joints taped and filled in accordance with Knauf recommendations. Systems are tested as imperforate.

EN Compliance Specifications

Knauf Performer - MW Acoustic Stud - Soundshield Plus (EN Compliance)



Got a question? Email our Technical Service on technical-uk@knauf.com or call 0800 521050 (option 2)

70mm Stud Solutions

Knauf Stud depth and gauge (mm)	Knauf Plasterboard layers to each side of Knauf Stud (no)	Thickness of Knauf Plasterboard (mm)	Knauf Plasterboard	Knauf Insulation Acoustic Roll - Cavity Insulation (mm)	System width (mm) excluding finishes	System code & Maximum height ¹ (mm) @ 600mm centres	System code & Maximum height ¹ (mm) @ 400mm centres	System code & Maximum height ¹ (mm) @ 300mm centres	Fire resistance period ² (minutes)	Acoustic Sound Insulation ³ (dB Rw)	Acoustic Sound Insulation ³ (Rw + Ctr) dB	Deflection allowance (mm)	Deflection head arrangement			
70 'MW' Acoustic Studs (0.55)	2	12.5	Soundshield Plus	50	122	EN-PMW-70-055-6-2-12.5-SSP-50	4500	EN-PMW-70-055-4-2-12.5-SSP-50	4700	EN-PMW-70-055-3-2-12.5-SSP-50	4900	60	57	50	-25	Figure 4
	2	12.5	Soundshield Plus	50	122	EN-PMW-70-055-6-2-12.5-SSP-50	4500	EN-PMW-70-055-4-2-12.5-SSP-50	4700	EN-PMW-70-055-3-2-12.5-SSP-50	4900	60	57	50	-50	Figure 8
	2	15	Soundshield Plus	50	132	EN-PMW-70-055-6-2-15-SSP-50*	4800	EN-PMW-70-055-4-2-15-SSP-50*	5000	EN-PMW-70-055-3-2-15-SSP-50*	5000	90	57	52	-25	Figure 4
	2	15	Soundshield Plus	50	132	EN-PMW-70-055-6-2-15-SSP-50*	4800	EN-PMW-70-055-4-2-15-SSP-50*	5000	EN-PMW-70-055-3-2-15-SSP-50*	5000	90	57	52	-50	Figure 8
	2	15	Soundshield Plus	50	132	EN-PMW-70-055-6-2-15-SSP-50**	4800	EN-PMW-70-055-4-2-15-SSP-50**	5000	EN-PMW-70-055-3-2-15-SSP-50**	5000	120	57	52	-25	Figure 14
	2	15	Soundshield Plus	50	132	EN-PMW-70-055-6-2-15-SSP-50**	4800	EN-PMW-70-055-4-2-15-SSP-50**	5000	EN-PMW-70-055-3-2-15-SSP-50**	5000	120	57	52	-50	Figure 16

* (90) ** (120)

92mm Stud Solutions

Knauf Stud depth and gauge (mm)	Knauf Plasterboard layers to each side of Knauf Stud (no)	Thickness of Knauf Plasterboard (mm)	Knauf Plasterboard	Knauf Insulation Acoustic Roll - Cavity Insulation (mm)	System width (mm) excluding finishes	System code & Maximum height ¹ (mm) @ 600mm centres	System code & Maximum height ¹ (mm) @ 400mm centres	System code & Maximum height ¹ (mm) @ 300mm centres	Fire resistance period ² (minutes)	Acoustic Sound Insulation ³ (dB Rw)	Acoustic Sound Insulation ³ (Rw + Ctr) dB	Deflection allowance (mm)	Deflection head arrangement			
92 'MW' Acoustic Studs (0.55)	2	12.5	Soundshield Plus	50	144	EN-PMW-92-055-6-2-12.5-SSP-50	5000	EN-PMW-92-055-4-2-12.5-SSP-50	5000	EN-PMW-92-055-3-2-12.5-SSP-50	5000	60	57	50	-25	Figure 4
	2	12.5	Soundshield Plus	50	144	EN-PMW-92-055-6-2-12.5-SSP-50	5000	EN-PMW-92-055-4-2-12.5-SSP-50	5000	EN-PMW-92-055-3-2-12.5-SSP-50	5000	60	57	50	-50	Figure 8
	2	15	Soundshield Plus	50	154	EN-PMW-92-055-6-2-15-SSP-50*	5000	EN-PMW-92-055-4-2-15-SSP-50*	5000	EN-PMW-92-055-3-2-15-SSP-50*	5000	90	57	52	-25	Figure 4
	2	15	Soundshield Plus	50	154	EN-PMW-92-055-6-2-15-SSP-50*	5000	EN-PMW-92-055-4-2-15-SSP-50*	5000	EN-PMW-92-055-3-2-15-SSP-50*	5000	90	57	52	-50	Figure 8
	2	15	Soundshield Plus	50	154	EN-PMW-92-055-6-2-15-SSP-50**	5000	EN-PMW-92-055-4-2-15-SSP-50**	5000	EN-PMW-92-055-3-2-15-SSP-50**	5000	120	57	52	-25	Figure 14
	2	15	Soundshield Plus	50	154	EN-PMW-92-055-6-2-15-SSP-50**	5000	EN-PMW-92-055-4-2-15-SSP-50**	5000	EN-PMW-92-055-3-2-15-SSP-50**	5000	120	57	52	-50	Figure 16

* (90) ** (120)

Knauf Performer - I Stud - Soundshield Plus (EN Compliance)

146mm Stud Solutions

Knauf Stud depth and gauge (mm)	Knauf Plasterboard layers to each side of Knauf Stud (no)	Thickness of Knauf Plasterboard (mm)	Knauf Plasterboard	Knauf Insulation Acoustic Roll - Cavity Insulation (mm)	System width (mm) excluding finishes	System code & Maximum height ¹ (mm) @ 600mm centres	System code & Maximum height ¹ (mm) @ 400mm centres	System code & Maximum height ¹ (mm) @ 300mm centres	Fire resistance period ² (minutes)	Acoustic Sound Insulation ³ (dB Rw)	Deflection allowance (mm)	Deflection head arrangement			
146 'I' Stud (0.90)	2	15	Soundshield Plus	50	208	EN-PI-146-090-6-2-15-SSP-50	7000	EN-PI-146-090-6-4-15-SSP-50	7000	EN-PI-146-090-6-3-15-SSP-50	7000	90	Estimated 53	-25	Figure 17
	2	15	Soundshield Plus	50	208	EN-PI-146-090-6-2-15-SSP-50	7000	EN-PI-146-090-6-4-15-SSP-50	7000	EN-PI-146-090-6-3-15-SSP-50	7000	90	Estimated 53	-50	Figure 18

1. Maximum height for EN Compliance Systems: The stated maximum height figure is the lower value between maximum cold state height, calculated to limiting deflection of L/240 @ 200 Pascals and the fire state height, as outlined in accordance with BS EN 1364-1 and BS EN 15254-3.
2. Fire resistance period: Tested in accordance with BS EN 1364-1. Fire resistance period is inclusive of fire integrity and fire insulation (EI). Fire resistance performance must be reviewed against Knauf specifications and standard details.
3. Acoustic sound insulation: Tested or assessed in accordance with BS EN ISO 10140-1 and BS EN 10140-2. Important - Acoustic Sound Insulation Performance based on Knauf studs at 600mm centres and non-deflection arrangement. Systems that are fire resistance and / or offering acoustic sound performance must have all outer joints taped and filled in accordance with Knauf recommendations. Systems are tested as imperforate.

Knauf Performer - Partition with Knauf Resilient Bar (EN Compliance)



Got a question? Email our Technical Service on technical-uk@knauf.com or call 0800 521050 (option 2)

70mm Stud Solutions

Knauf Stud depth and gauge (mm)	Knauf Plasterboard layers to each side of Knauf Stud (no)	Thickness of Knauf Plasterboard (mm)	Knauf Plasterboard	Knauf Resilient Bar	Knauf Insulation Acoustic Roll - Cavity Insulation (mm)	System width (mm) excluding finishes	Knauf Stud centres (mm)	System code & Maximum height ¹ (mm)	Fire resistance period ² (minutes)	Acoustic Sound Insulation ³ (dB Rw)	Acoustic Sound Insulation ³ (Rw + Ctr) dB	Deflection allowance (mm)	Deflection head arrangement	
70 'C' Stud (0.55)	2	15	Soundshield Plus	Fixed to one side spanning across Knauf Stud Studs at 600mm vertical centres	50	148	600	EN-PC-RB1-70-055-6-2-15-SSP-50(60)	3000	60	60	55	-25	Figure 19
	2	15	Soundshield Plus	Fixed to one side spanning across Knauf Stud Studs at 600mm vertical centres	50	148	600	EN-PC-RB1-70-055-6-2-15-SSP-50(60)	3000	60	60	55	-50	Figure 21
	2	15	Soundshield Plus	Fixed to one side spanning across Knauf Stud Studs at 600mm vertical centres	50	148	600	EN-PC-RB1-70-055-6-2-15-SSP-50(120)	3000	120	60	55	-25	Figure 20
	2	15	Soundshield Plus	Fixed to one side spanning across Knauf Stud Studs at 600mm vertical centres	50	148	600	EN-PC-RB1-70-055-6-2-15-SSP-50(120)	3000	120	60	55	-50	Figure 22

1. Maximum height for EN Compliance Systems: The stated maximum height figure is the lower value between maximum cold state height, calculated to limiting deflection of L/240 @ 200 Pascals and the fire state height, as outlined in accordance with BS EN 1364-1.

2. Fire resistance period: Tested in accordance with BS EN 1364-1. Fire resistance period is inclusive of fire integrity and fire insulation (EI). Fire resistance performance must be reviewed against Knauf specifications and standard details.

3. Acoustic sound insulation: Tested or assessed in accordance with BS EN ISO 10140-1 and BS EN 10140-2. Important - Acoustic Sound Insulation Performance based on Knauf studs at 600mm centres and non-deflection arrangement.

Systems that are fire resistance and / or offering acoustic sound performance must have all outer joints taped and filled in accordance with Knauf recommendations. Systems are tested as imperforate.

Knauf AQUAPANEL® Interior System (EN Compliance)

70mm Stud Solutions

Knauf Stud depth and gauge (mm)	Knauf Plasterboard layers to each side of Knauf Stud (no)	Thickness of Knauf Plasterboard (mm)	Knauf Cement Board	Knauf Insulation Acoustic Roll - Cavity Insulation (mm)	System width (mm) excluding finishes	Knauf Stud centres (mm)	System code & Maximum height ¹ (mm)	Fire resistance period ² (minutes)	Acoustic Sound Insulation ³ (dB Rw)	Deflection allowance (mm)	Deflection head arrangement
70 'C' Stud (0.55)	1	12.5	AQUAPANEL® Indoor	25	97	600	EN-PAC-70-060-6-1-12.5-AQP-25	3000	Not Tested	-25	Figure 23
						400	EN-PAC-70-060-6-1-12.5-AQP-25	3300			
						300	EN-PAC-70-060-3-1-12.5-AQP-25	3600			

1. Maximum height for EN Compliance Systems: The stated maximum height figure is the lower value between maximum cold state height, calculated to limiting deflection of L/500 @ 200 Pascals and the fire state height, as outlined in accordance with BS EN 1364-1 and BS EN 15254-3.

2. Fire resistance period: Tested in accordance with BS EN 1364-1. Fire resistance period is inclusive of fire integrity and fire insulation (EI). Fire resistance performance must be reviewed against Knauf specifications and standard details.

3. Acoustic sound insulation: Tested or assessed in accordance with BS EN ISO 10140-1 and BS EN 10140-2. Important - Acoustic Sound Insulation Performance based on Knauf studs at 600mm centres and non-deflection arrangement.

Systems that are fire resistance and / or offering acoustic sound performance must have all outer joints taped and filled in accordance with Knauf recommendations. Systems are tested as imperforate.

Knauf Isolator - Twin Frame Partitions (EN Compliance)



Got a question? Email our Technical Service on technical-uk@knauf.com or call 0800 521050 (option 2)

50/60/70mm Stud Solutions (-25mm Deflection Allowance)

Knauf Stud depth and gauge (mm)	Knauf Plasterboard layers to each side of Knauf Stud (no)	Thickness of Knauf Plasterboard (mm)	Knauf Plasterboard (Inner layer - both sides)	Knauf Plasterboard (Outer layer - both sides)	Bracing required*	Knauf Insulation Acoustic Roll - Cavity Insulation (mm)	System width (mm) excluding finishes	Knauf Stud centres (mm)	System code & Maximum height ¹ (mm)	Fire resistance period ² (minutes)	Acoustic Sound Insulation ³ (dB Rw)	Acoustic Sound Insulation ³ (Rw + Ctr) dB	Deflection allowance (mm)	Deflection head arrangement		
Double 50 'C' (0.55)	2	15	Soundshield Plus	Soundshield Plus	Yes	2 x 25	170	600	EN-ICB-50-055-6-2-15-SSP-2x25(170/90)	4000	90	58	51	-25	Figure 24	
								400	EN-ICB-50-055-4-2-15-SSP-2x25(170/90)	4000						
								300	EN-ICB-50-055-3-2-15-SSP-2x25(170/90)	4000						
Double 50 'I' (0.55)	2	15	Soundshield Plus	Soundshield Plus	No	1 x 50	200	600	EN-II-50-055-6-2-15-SSP-1x50(200/120)	2900	120	62	56	-25	Figure 28	
								400	EN-II-50-055-4-2-15-SSP-1x50(200/120)	3300						
								300	EN-II-50-055-3-2-15-SSP-1x50(200/120)	3600						
Double 60 'I' (0.55)	2	15	Soundshield Plus	Soundshield Plus	No	1 x 50	220	600	EN-II-60-055-6-2-15-SSP-1x50(220/120)	3300	120	62	56	-25	Figure 28	
								400	EN-II-60-055-4-2-15-SSP-1x50(220/120)	3700						
								300	EN-II-60-055-3-2-15-SSP-1x50(220/120)	4000						
Double 70 'C' (0.55)	2	15	Soundshield Plus	Soundshield Plus	No	2 x 25	229	600	EN-IC-70-055-6-2-15-SSP-2x25(229/60)	3000	60	65	60	-25	Figure 24	
								400	EN-IC-70-055-4-2-15-SSP-2x25(229/60)	3000						
								300	EN-IC-70-055-3-2-15-SSP-2x25(229/60)	3000						
	2	15	Soundshield Plus	Soundshield Plus	No	2 x 25	229	229	600	EN-IC-70-055-6-2-15-SSP-2x25(229/90)	3000	90	65	60	-25	Figure 24
									400	EN-IC-70-055-4-2-15-SSP-2x25(229/90)	3000					
									300	EN-IC-70-055-3-2-15-SSP-2x25(229/90)	3000					
	2	15	Soundshield Plus	Soundshield Plus	No	2 x 25	229	229	600	EN-IC-70-055-6-2-15-SSP-2x25(229/120)	3000	120**	65	60	-25	Figure 26
									400	EN-IC-70-055-4-2-15-SSP-2x25(229/120)	3000					
									300	EN-IC-70-055-3-2-15-SSP-2x25(229/120)	3000					
	2	15	Soundshield Plus	Soundshield Plus	Yes	2 x 25	214	214	600	EN-ICB-70-055-6-2-15-SSP-2x25(214/120)	6000	120	60	53	-25	Figure 26
									400	EN-ICB-70-055-4-2-15-SSP-2x25(214/120)	6000					
									300	EN-ICB-70-055-3-2-15-SSP-2x25(214/120)	6000					
Double 70 'I' (0.70)	2	15	Soundshield Plus	Soundshield Plus	No	1 x 100	250	600	EN-II-70-070-6-2-15-SSP-1x100(250/120)	4000	120	66	61	-25	Figure 30	
								400	EN-II-70-070-4-2-15-SSP-1x100(250/120)	4000						
								300	EN-II-70-070-3-2-15-SSP-1x100(250/120)	4000						

*Bracing of double studs using Knauf Flat Plate at 1500mm vertical centres

**System fire resistance tested with the inclusion of baffle boxes

1. **Maximum height for EN Compliance Systems:** The stated maximum height figure is the lower value between maximum cold state height, calculated to limiting deflection of L/240 @ 200 Pascals and the fire state height, as outlined in accordance with BS EN 1364-1.

2. **Fire resistance period:** Tested in accordance with BS EN 1364-1. Fire resistance period is inclusive of fire integrity and fire insulation (EI). Fire resistance performance must be reviewed against Knauf specifications and standard details.

3. **Acoustic sound insulation:** Tested or assessed in accordance with BS EN ISO 10140-1 and BS EN 10140-2. Important - Acoustic Sound Insulation Performance based on Knauf studs at 600mm centres and non-deflection arrangement. Systems that are fire resistance and / or offering acoustic sound performance must have all outer joints taped and filled in accordance with Knauf recommendations. Systems are tested as imperforate.

Knauf Isolator - Twin Frame Partitions (EN Compliance)



Got a question? Email our Technical Service on technical-uk@knauf.com or call 0800 521050 (option 2)

50/60/70mm Stud Solutions (-50mm Deflection Allowance)

Knauf Stud depth and gauge (mm)	Knauf Plasterboard layers to each side of Knauf Stud (no)	Thickness of Knauf Plasterboard (mm)	Knauf Plasterboard (Inner layer - both sides)	Knauf Plasterboard (Outer layer - both sides)	Bracing required*	Knauf Insulation Acoustic Roll - Cavity Insulation (mm)	System width (mm) excluding finishes	Knauf Stud centres (mm)	System code & Maximum height ¹ (mm)	Fire resistance period ² (minutes)	Acoustic Sound Insulation ³ (dB Rw)	Acoustic Sound Insulation ³ (Rw + Ctr) dB	Deflection allowance (mm)	Deflection head arrangement		
Double 50 'C' (0.55)	2	15	Soundshield Plus	Soundshield Plus	Yes	2 x 25	170	600	EN-ICB-50-055-6-2-15-SSP-2x25(170/90)	4000	90	58	51	-50	Figure 32	
								400	EN-ICB-50-055-4-2-15-SSP-2x25(170/90)	4000						
								300	EN-ICB-50-055-3-2-15-SSP-2x25(170/90)	4000						
Double 50 'I' (0.55)	2	15	Soundshield Plus	Soundshield Plus	No	1 x 50	200	600	EN-II-50-055-6-2-15-SSP-1x50(200/120)	2900	120	62	56	-50	Figure 36	
								400	EN-II-50-055-4-2-15-SSP-1x50(200/120)	3300						
								300	EN-II-50-055-3-2-15-SSP-1x50(200/120)	3600						
Double 60 'I' (0.55)	2	15	Soundshield Plus	Soundshield Plus	No	1 x 50	220	600	EN-II-60-055-6-2-15-SSP-1x50(220/120)	3300	120	62	56	-50	Figure 36	
								400	EN-II-60-055-4-2-15-SSP-1x50(220/120)	3700						
								300	EN-II-60-055-3-2-15-SSP-1x50(220/120)	4000						
Double 70 'C' (0.55)	2	15	Soundshield Plus	Soundshield Plus	No	2 x 25	229	600	EN-IC-70-055-6-2-15-SSP-2x25(229/60)	3000	60	65	60	-50	Figure 32	
								400	EN-IC-70-055-4-2-15-SSP-2x25(229/60)	3000						
								300	EN-IC-70-055-3-2-15-SSP-2x25(229/60)	3000						
	2	15	Soundshield Plus	Soundshield Plus	No	2 x 25	229	229	600	EN-IC-70-055-6-2-15-SSP-2x25(229/90)	3000	90	65	60	-50	Figure 32
									400	EN-IC-70-055-4-2-15-SSP-2x25(229/90)	3000					
									300	EN-IC-70-055-3-2-15-SSP-2x25(229/90)	3000					
	2	15	Soundshield Plus	Soundshield Plus	No	2 x 25	229	229	600	EN-IC-70-055-6-2-15-SSP-2x25(229/120)	3000	120**	65	60	-50	Figure 34
									400	EN-IC-70-055-4-2-15-SSP-2x25(229/120)	3000					
									300	EN-IC-70-055-3-2-15-SSP-2x25(229/120)	3000					
	2	15	Soundshield Plus	Soundshield Plus	Yes	2 x 25	214	214	600	EN-ICB-70-055-6-2-15-SSP-2x25(214/120)	6000	120	60	53	-50	Figure 34
									400	EN-ICB-70-055-4-2-15-SSP-2x25(214/120)	6000					
									300	EN-ICB-70-055-3-2-15-SSP-2x25(214/120)	6000					
Double 70 'I' (0.70)	2	15	Soundshield Plus	Soundshield Plus	No	1 x 100	250	600	EN-II-70-070-6-2-15-SSP-1x100(250/120)	4000	120	66	61	-50	Figure 38	
								400	EN-II-70-070-4-2-15-SSP-1x100(250/120)	4000						
								300	EN-II-70-070-3-2-15-SSP-1x100(250/120)	4000						

*Bracing of double studs using Knauf Flat Plate at 1500mm vertical centres

**System fire resistance tested with the inclusion of baffle boxes

1. **Maximum height for EN Compliance Systems:** The stated maximum height figure is the lower value between maximum cold state height, calculated to limiting deflection of L/240 @ 200 Pascals and the fire state height, as outlined in accordance with BS EN 1364-1.

2. **Fire resistance period:** Tested in accordance with BS EN 1364-1. Fire resistance period is inclusive of fire integrity and fire insulation (EI). Fire resistance performance must be reviewed against Knauf specifications and standard details.

3. **Acoustic sound insulation:** Tested or assessed in accordance with BS EN ISO 10140-1 and BS EN 10140-2. Important - Acoustic Sound Insulation Performance based on Knauf studs at 600mm centres and non-deflection arrangement. Systems that are fire resistance and / or offering acoustic sound performance must have all outer joints taped and filled in accordance with Knauf recommendations. Systems are tested as imperforate.

Knauf Isolator - Twin Frame Partitions - Hybrid (EN Compliance)



Got a question? Email our Technical Service on technical-uk@knauf.com or call 0800 521050 (option 2)

50/60/70mm Stud Solutions (-25mm Deflection Allowance)

Knauf Stud depth and gauge (mm)	Knauf Plasterboard layers to each side of Knauf Stud (no)	Thickness of Knauf Plasterboard (mm)	Knauf Plasterboard (Inner layer - both sides)	Knauf Plasterboard (Outer layer - both sides)	Bracing required*	Knauf Insulation Acoustic Roll - Cavity Insulation (mm)	System width (mm) excluding finishes	Knauf Stud centres (mm)	System code & Maximum height ¹ (mm)	Fire resistance period ² (minutes)	Acoustic Sound Insulation ³ (dB Rw)	Acoustic Sound Insulation ³ (Rw + Ctr) dB	Deflection allowance (mm)	Deflection head arrangement	
Double 50 'I' (0.55)	2	15	Soundshield Plus	Performance Plus	No	1 x 50	200	600	EN-II-50-055-6-1x15-SSP-1x15-PP-1x50(200/120)	2900	120	62	56	-25	Figure 29
								400	EN-II-50-055-4-1x15-SSP-1x15-PP-1x50(200/120)	3300					
								300	EN-II-50-055-3-1x15-SSP-1x15-PP-1x50(200/120)	3600					
Double 60 'I' (0.55)	2	15	Soundshield Plus	Performance Plus	No	1 x 50	220	600	EN-II-60-055-6-1x15-SSP-1x15-PP-1x50(220/120)	3300	120	62	56	-25	Figure 29
								400	EN-II-60-055-4-1x15-SSP-1x15-PP-1x50(220/120)	3700					
								300	EN-II-60-055-3-1x15-SSP-1x15-PP-1x50(220/120)	4000					
Double 70 'C' (0.55)	2	15	Soundshield Plus	Performance Plus	No	2 x 25	229	600	EN-IC-70-055-6-1x15-SSP-1x15-PP-2x25(229/60)	3000	60	65	60	-25	Figure 25
								400	EN-IC-70-055-4-1x15-SSP-1x15-PP-2x25(229/60)	3000					
								300	EN-IC-70-055-3-1x15-SSP-1x15-PP-2x25(229/60)	3000					
	2	15	Soundshield Plus	Performance Plus	No	2 x 25	229	600	EN-IC-70-055-6-1x15-SSP-1x15-PP-2x25(229/90)	3000	90	65	60	-25	Figure 25
								400	EN-IC-70-055-4-1x15-SSP-1x15-PP-2x25(229/90)	3000					
								300	EN-IC-70-055-3-1x15-SSP-1x15-PP-2x25(229/90)	3000					
	2	15	Soundshield Plus	Performance Plus	No	2 x 25	229	600	EN-IC-70-055-6-1x15-SSP-1x15-PP-2x25(229/120)	3000	120	65	60	-25	Figure 27
								400	EN-IC-70-055-4-1x15-SSP-1x15-PP-2x25(229/120)	3000					
								300	EN-IC-70-055-3-1x15-SSP-1x15-PP-2x25(229/120)	3000					
Double 70 'I' (0.70)	2	15	Soundshield Plus	Performance Plus	No	1 x 100	250	600	EN-II-70-070-6-1x15-SSP-1x15-PP-1x100(250/120)	4000	120	66	61	-25	Figure 31
								400	EN-II-70-070-4-1x15-SSP-1x15-PP-1x100(250/120)	4000					
								300	EN-II-70-070-3-1x15-SSP-1x15-PP-1x100(250/120)	4000					

*Bracing of double studs using Knauf Flat Plate at 1500mm vertical centres

1. **Maximum height for EN Compliance Systems:** The stated maximum height figure is the lower value between maximum cold state height, calculated to limiting deflection of L/240 @ 200 Pascals and the fire state height, as outlined in accordance with BS EN 1364-1.
 2. **Fire resistance period:** Tested in accordance with BS EN 1364-1. Fire resistance period is inclusive of fire integrity and fire insulation (EI). Fire resistance performance must be reviewed against Knauf specifications and standard details.
 3. **Acoustic sound insulation:** Tested or assessed in accordance with BS EN ISO 10140-1 and BS EN 10140-2. Important - Acoustic Sound Insulation Performance based on Knauf studs at 600mm centres and non-deflection arrangement. Systems that are fire resistance and / or offering acoustic sound performance must have all outer joints taped and filled in accordance with Knauf recommendations. Systems are tested as imperforate.

Knauf Isolator - Twin Frame Partitions - Hybrid (EN Compliance)



Got a question? Email our Technical Service on technical-uk@knauf.com or call 0800 521050 (option 2)

50/60/70mm Stud Solutions (-50mm Deflection Allowance)

Knauf Stud depth and gauge (mm)	Knauf Plasterboard layers to each side of Knauf Stud (no)	Thickness of Knauf Plasterboard (mm)	Knauf Plasterboard (Inner layer - both sides)	Knauf Plasterboard (Outer layer - both sides)	Bracing required*	Knauf Insulation Acoustic Roll - Cavity Insulation (mm)	System width (mm) excluding finishes	Knauf Stud centres (mm)	System code & Maximum height ¹ (mm)	Fire resistance period ² (minutes)	Acoustic Sound Insulation ³ (dB Rw)	Acoustic Sound Insulation ³ (Rw + Ctr) dB	Deflection allowance (mm)	Deflection head arrangement	
Double 50 'I' (0.55)	2	15	Soundshield Plus	Performance Plus	No	1 x 50	200	600	EN-II-50-055-6-1x15-SSP-1x15-PP-1x50(200/120)	2900	120	62	56	-50	Figure 37
								400	EN-II-50-055-4-1x15-SSP-1x15-PP-1x50(200/120)	3300					
								300	EN-II-50-055-3-1x15-SSP-1x15-PP-1x50(200/120)	3600					
Double 60 'I' (0.55)	2	15	Soundshield Plus	Performance Plus	No	1 x 50	220	600	EN-II-60-055-6-1x15-SSP-1x15-PP-1x50(220/120)	3300	120	62	56	-50	Figure 37
								400	EN-II-60-055-4-1x15-SSP-1x15-PP-1x50(220/120)	3700					
								300	EN-II-60-055-3-1x15-SSP-1x15-PP-1x50(220/120)	4000					
Double 70 'C' (0.55)	2	15	Soundshield Plus	Performance Plus	No	2 x 25	229	600	EN-IC-70-055-6-1x15-SSP-1x15-PP-2x25(229/60)	3000	60	65	60	-50	Figure 33
								400	EN-IC-70-055-4-1x15-SSP-1x15-PP-2x25(229/60)	3000					
								300	EN-IC-70-055-3-1x15-SSP-1x15-PP-2x25(229/60)	3000					
	2	15	Soundshield Plus	Performance Plus	No	2 x 25	229	600	EN-IC-70-055-6-1x15-SSP-1x15-PP-2x25(229/90)	3000	90	65	60	-50	Figure 33
								400	EN-IC-70-055-4-1x15-SSP-1x15-PP-2x25(229/90)	3000					
								300	EN-IC-70-055-3-1x15-SSP-1x15-PP-2x25(229/90)	3000					
	2	15	Soundshield Plus	Performance Plus	No	2 x 25	229	600	EN-IC-70-055-6-1x15-SSP-1x15-PP-2x25(229/120)	3000	120	65	60	-50	Figure 35
								400	EN-IC-70-055-4-1x15-SSP-1x15-PP-2x25(229/120)	3000					
								300	EN-IC-70-055-3-1x15-SSP-1x15-PP-2x25(229/120)	3000					
Double 70 'I' (0.70)	2	15	Soundshield Plus	Performance Plus	No	1 x 100	250	600	EN-II-70-070-6-1x15-SSP-1x15-PP-1x100(250/120)	4000	120	66	61	-50	Figure 39
								400	EN-II-70-070-4-1x15-SSP-1x15-PP-1x100(250/120)	4000					
								300	EN-II-70-070-3-1x15-SSP-1x15-PP-1x100(250/120)	4000					

*Bracing of double studs using Knauf Flat Plate at 1500mm vertical centres

1. **Maximum height for EN Compliance Systems:** The stated maximum height figure is the lower value between maximum cold state height, calculated to limiting deflection of L/240 @ 200 Pascals and the fire state height, as outlined in accordance with BS EN 1364-1.
 2. **Fire resistance period:** Tested in accordance with BS EN 1364-1. Fire resistance period is inclusive of fire integrity and fire insulation (EI). Fire resistance performance must be reviewed against Knauf specifications and standard details.
 3. **Acoustic sound insulation:** Tested or assessed in accordance with BS EN ISO 10140-1 and BS EN 10140-2. Important - Acoustic Sound Insulation Performance based on Knauf studs at 600mm centres and non-deflection arrangement. Systems that are fire resistance and / or offering acoustic sound performance must have all outer joints taped and filled in accordance with Knauf recommendations. Systems are tested as imperforate.

Knauf Shaftwall (EN Compliance)



Got a question? Email our Technical Service on technical-uk@knauf.com or call 0800 521050 (option 2)

60/92/146mm Stud Solutions

Knauf Stud depth and gauge (mm)	Knauf Plasterboards to lobby/room side	Integral Knauf Plasterboard to shaft side	Knauf Insulation Acoustic Roll - Cavity Insulation (mm)	System width (mm) excluding finishes	Knauf Stud centres (mm)	System code & Maximum height ¹ (mm)	Fire resistance period ² (minutes)	Acoustic Sound Insulation ³ (dB Rw)	Deflection allowance (mm)	Deflection head arrangement	
60 'CT' Stud (0.92)	2 x 12.5mm Knauf Fire Panel	19mm Coreboard	Non insulated	87	600	EN-SW-CT-60-092-6-2x12.5-FP-0	4000	60	Non Tested	-25	Figure 40
	2 x 12.5mm Knauf Fire Panel	19mm Coreboard	Non insulated	87	600	EN-SW-CT-60-092-6-2x12.5-FP-0	4000	60	Non Tested	-50	Figure 43
	2 x 15mm Knauf Fire Panel	19mm Coreboard	Non insulated	92	600	EN-SW-CT-60-092-6-2x15-FP-0	4000	90	Non Tested	-25	Figure 41
	2 x 15mm Knauf Fire Panel	19mm Coreboard	Non insulated	92	600	EN-SW-CT-60-092-6-2x15-FP-0	4000	90	Non Tested	-50	Figure 44
	3 x 15mm Knauf Fire Panel	19mm Coreboard	Non insulated	107	600	EN-SW-CT-60-092-6-3x15-FP-0	4000	120	Non Tested	-25	Figure 42
	3 x 15mm Knauf Fire Panel	19mm Coreboard	Non insulated	107	600	EN-SW-CT-60-092-6-3x15-FP-0	4000	120	Non Tested	-50	Figure 45
	3 x 15mm Knauf Fire Panel	19mm Coreboard	25	107	600	EN-SW-CT-60-092-6-3x15-FP-25	4000	120	50	-25	Figure 42
	3 x 15mm Knauf Fire Panel	19mm Coreboard	25	107	600	EN-SW-CT-60-092-6-3x15-FP-25	4000	120	50	-50	Figure 45
92 'CT' Stud (0.92)	2 x 12.5mm Knauf Fire Panel	19mm Coreboard	Non insulated	119	600	EN-SW-CT-92-092-6-2x12.5-FP-0	4000	60	Non Tested	-25	Figure 40
	2 x 12.5mm Knauf Fire Panel	19mm Coreboard	Non insulated	119	600	EN-SW-CT-92-092-6-2x12.5-FP-0	4000	60	Non Tested	-50	Figure 43
	2 x 15mm Knauf Fire Panel	19mm Coreboard	Non insulated	124	600	EN-SW-CT-92-092-6-2x15-FP-0	4000	90	Non Tested	-25	Figure 41
	2 x 15mm Knauf Fire Panel	19mm Coreboard	Non insulated	124	600	EN-SW-CT-92-092-6-2x15-FP-0	4000	90	Non Tested	-50	Figure 44
	3 x 15mm Knauf Fire Panel	19mm Coreboard	Non insulated	139	600	EN-SW-CT-92-092-6-3x15-FP-0	4000	120	Non Tested	-25	Figure 42
	3 x 15mm Knauf Fire Panel	19mm Coreboard	Non insulated	139	600	EN-SW-CT-92-092-6-3x15-FP-0	4000	120	Non Tested	-50	Figure 45
	3 x 15mm Knauf Fire Panel	19mm Coreboard	25	139	600	EN-SW-CT-92-092-6-3x15-FP-25	4000	120	50	-25	Figure 42
	3 x 15mm Knauf Fire Panel	19mm Coreboard	25	139	600	EN-SW-CT-92-092-6-3x15-FP-25	4000	120	50	-50	Figure 45
	3 x 15mm Knauf Fire Panel	19mm Coreboard	25	139	600	EN-SW-CT-92-092-6-3x15-FP-25(5m)	5000	90	50	-25	Figure 42
	3 x 15mm Knauf Fire Panel	19mm Coreboard	25	139	600	EN-SW-CT-92-092-6-3x15-FP-25(5m)	5000	90	50	-50	Figure 45
146 'CT' Stud (0.92)	2 x 12.5mm Knauf Fire Panel	19mm Coreboard	Non insulated	173	600	EN-SW-CT-146-092-6-2x12.5-FP-0	4000	60	Non Tested	-25	Figure 40
	2 x 12.5mm Knauf Fire Panel	19mm Coreboard	Non insulated	173	600	EN-SW-CT-146-092-6-2x12.5-FP-0	4000	60	Non Tested	-50	Figure 43
	2 x 15mm Knauf Fire Panel	19mm Coreboard	Non insulated	178	600	EN-SW-CT-146-092-6-2x15-FP-0	4000	90	Non Tested	-25	Figure 41
	2 x 15mm Knauf Fire Panel	19mm Coreboard	Non insulated	178	600	EN-SW-CT-146-092-6-2x15-FP-0	4000	90	Non Tested	-50	Figure 44
	3 x 15mm Knauf Fire Panel	19mm Coreboard	Non insulated	193	600	EN-SW-CT-146-092-6-3x15-FP-0	4000	120	Non Tested	-25	Figure 42
	3 x 15mm Knauf Fire Panel	19mm Coreboard	Non insulated	193	600	EN-SW-CT-146-092-6-3x15-FP-0	4000	120	Non Tested	-50	Figure 45
	3 x 15mm Knauf Fire Panel	19mm Coreboard	25	193	600	EN-SW-CT-146-092-6-3x15-FP-25	4000	120	50	-25	Figure 42
	3 x 15mm Knauf Fire Panel	19mm Coreboard	25	193	600	EN-SW-CT-146-092-6-3x15-FP-25	4000	120	50	-50	Figure 45
	3 x 15mm Knauf Fire Panel	19mm Coreboard	25	193	600	EN-SW-CT-146-092-6-3x15-FP-25(5m)	5000	90	50	-25	Figure 42
	3 x 15mm Knauf Fire Panel	19mm Coreboard	25	193	600	EN-SW-CT-146-092-6-3x15-FP-25(5m)	5000	90	50	-50	Figure 45

1. Maximum height for EN Compliance Systems: For all Knauf Shaftwall systems follows the requirements as outlined within BS EN 1364-1 and Direct Field of Application (DIAP). The stated maximum height figure is the lower value between the cold state height, calculated to limiting deflection of L/240 and the fire state height.

2. Fire resistance period: Tested in accordance with BS EN 1364-1. Fire resistance period is inclusive of fire integrity and fire insulation (EI). Fire resistance performance must be reviewed against Knauf specifications and standard details.

3. Acoustic sound insulation: Tested or assessed in accordance with BS EN ISO 10140-1 and BS EN 10140-2. Important - Acoustic Sound Insulation Performance based on Knauf studs at 600mm centres and non-deflection arrangement. Systems that are fire resistance and / or offering acoustic sound performance must have all outer joints taped and filled in accordance with Knauf recommendations. Systems are tested as imperforate.

Knauf 'I' Stud Linings - Fire Resistance Performance Systems (EN Compliance)



Got a question? Email our Technical Service on technical-uk@knauf.com or call 0800 521050 (option 2)

70/92mm Stud Solutions

Knauf Stud depth and gauge (mm)	Knauf plasterboards to room side	Knauf Insulation RocksilK RS60 - Cavity Insulation (mm)	System width (mm) excluding finishes	Knauf Stud centres (mm)	System code & Maximum height ¹ (mm)	Fire resistance period ² (minutes)	Acoustic Sound Insulation ³ (dB Rw)	Deflection allowance (mm)	Deflection head arrangement		
70 'I' Stud (0.70)	2 x 15mm Fire Panel	50	102	600	EN-ISL-I-70-070-6-2x15-FP-50	4000	Not Tested	-25	Figure 47		
				400	EN-ISL-I-70-070-4-2x15-FP-50	4000					
				300	EN-ISL-I-70-070-3-2x15-FP-50	4000					
	2 x 15mm Fire Panel	50	102	600	EN-ISL-I-70-070-6-2x15-FP-50	4000	60	Not Tested	-50	Figure 48	
					400	EN-ISL-I-70-070-4-2x15-FP-50					4000
					300	EN-ISL-I-70-070-4-2x15-FP-50					4000
92 'I' Stud (0.90)	2 x 15mm Fire Panel	50	124	600	EN-ISL-I-92-090-6-2x15-FP-50	5000	Not Tested	-25	Figure 47		
				400	EN-ISL-I-92-090-4-2x15-FP-50	5000					
				300	EN-ISL-I-92-090-3-2x15-FP-50	5000					
	2 x 15mm Fire Panel	50	124	600	EN-ISL-I-92-090-6-2x15-FP-50	5000	60	Not Tested	-50	Figure 48	
					400	EN-ISL-I-92-090-4-2x15-FP-50					5000
					300	EN-ISL-I-92-090-3-2x15-FP-50					5000

1. Maximum height for EN Compliance Systems: The stated maximum height figure is the lower value between maximum cold state height, calculated to limiting deflection of L/240 @ 200 Pascals and the fire state height, as outlined in accordance with BS EN 1364-1.

2. Fire resistance period: Tested in accordance with BS EN 1364-1. Fire resistance period is inclusive of fire integrity and fire insulation (EI). Fire resistance performance must be reviewed against Knauf specifications and standard details.

3. Acoustic sound insulation: Tested or assessed in accordance with BS EN ISO 10140-1 and BS EN 10140-2. Important - Acoustic Sound Insulation Performance based on Knauf studs at 600mm centres and non-deflection arrangement. Systems that are fire resistance and / or offering acoustic sound performance must have all outer joints taped and filled in accordance with Knauf recommendations. Systems are tested as imperforate.

Knauf 'I' Stud Linings - Non-Fire Resistance Performance Systems (EN Compliance)



Got a question? Email our Technical Service on technical-uk@knauf.com or call 0800 521050 (option 2)

50/60/70/92/146mm Stud Solutions

Knauf Stud depth and gauge (mm)	Knauf Plasterboard layers to room side	Thickness of Knauf Plasterboard (mm)	Knauf plasterboard to suit specification*	Overall lining width (excluding finishes)	Maximum height ¹ with stud centres 600mm	Maximum height ¹ with stud centres 400mm	Maximum height ¹ with stud centres 300mm
50 'I' Stud (0.55)	1	12.5	Knauf plasterboard to suit specification	64.5	2900	3300	3600
	2	12.5	Knauf plasterboard to suit specification	77	2900	3300	3600
	1	15	Knauf plasterboard to suit specification	67	2900	3300	3600
	2	15	Knauf plasterboard to suit specification	82	2900	3300	3600
60 'I' Stud (0.70)	1	12.5	Knauf plasterboard to suit specification	74.5	3600	4100	4500
	2	12.5	Knauf plasterboard to suit specification	87	3600	4100	4500
	1	15	Knauf plasterboard to suit specification	77	3600	4100	4500
	2	15	Knauf plasterboard to suit specification	92	3600	4100	4500
70 'I' Stud (0.70)	1	12.5	Knauf plasterboard to suit specification	84.5	4000	4600	5000
	2	12.5	Knauf plasterboard to suit specification	97	4000	4600	5000
	1	15	Knauf plasterboard to suit specification	87	4000	4600	5000
	2	15	Knauf plasterboard to suit specification	102	4000	4600	5000
92 'I' Stud (0.90)	1	12.5	Knauf plasterboard to suit specification	106.5	5300	6100	6700
	2	12.5	Knauf plasterboard to suit specification	119	5300	6100	6700
	1	15	Knauf plasterboard to suit specification	109	5300	6100	6700
	2	15	Knauf plasterboard to suit specification	124	5300	6100	6700
146 'I' Stud (0.90)	1	12.5	Knauf plasterboard to suit specification	158.5	7500	8600	9400
	2	12.5	Knauf plasterboard to suit specification	173	7500	8600	9400
	1	15	Knauf plasterboard to suit specification	163	7500	8600	9400
	2	15	Knauf plasterboard to suit specification	178	7500	8600	9400

*Various Knauf plasterboards can be used for such system arrangement

Knauf Smokeshaft (EN Compliance)



Got a question? Email our Technical Service on technical-uk@knauf.com or call 0800 521050 (option 2)

60mm Stud Solution

Knauf Stud depth and gauge (mm)	Knauf number of layers and board to lobby side	Integral Knauf board to shaft side	Knauf Insulation Acoustic Roll - Cavity Insulation (mm)	System width (mm) excluding finishes	Knauf Stud centres (mm)	System code & Maximum height ¹ (mm)	Fire resistance period ² (minutes)	Acoustic Sound Insulation (dB Rw)	Deflection allowance (mm)	Deflection head arrangement
60 'I' Stud (0.70)	3 x 15mm Fireboard	15mm Fireboard	Non Insulated	107	600	EN-SS-I-60-070-3x15-FB-0	4000 120	46	-25	Figure 46

1. Maximum height: The stated maximum height is the lower value between cold state height, calculated to a limiting deflection of L/240 @ 200 Pascals and the fire state, as outlined in accordance with BS EN 1364-1 and Direct Field of Application (DIAP).

2. Fire resistance period: Tested in accordance with BS EN 1364-1. Fire resistance period is inclusive of fire integrity and fire insulation (EI). Fire resistance performance must be reviewed against Knauf specifications and standard details.

3. Acoustic sound insulation: Tested or assessed in accordance with BS EN ISO 10140-1 and BS EN 10140-2. Important - Acoustic Sound Insulation Performance based on Knauf studs at 600mm centres and non-deflection arrangement. Systems that are fire resistance and/or offering acoustic sound performance must have all outer joints taped and filled in accordance with Knauf recommendations. Systems are tested as imperforate.

Note: System has not been tested in accordance with BS EN 1366-8:2024. If your project requires conformity to this standard, use an alternative approved construction type.

Knauf Horizontal Shaftwall - Ceiling System (EN Compliance)

Knauf Stud depth and gauge (mm)	Knauf plasterboards to underside of double Knauf 'CT' Studs	Thickness of Knauf Plasterboard (mm)	Knauf Plasterboard	Knauf Insulation RocksilK® RS60 layed above double Knauf 'CT' Studs	System width (mm) excluding finishes	Knauf double stud joist centres (mm)	Knauf double stud joist centres (mm) and maximum ceiling span	Fire resistance period ¹ (minutes)
Double 92 'CT' Stud (0.92)	3	12.5	Fire Panel	50	181.5	600	HSW-2xCT-92-092-6-3x12.5-FP-50	4000 60

1. System performance stated is based on directions from below to above and above to below accordance with BS EN 1364-2.

Fire resistance period: Tested in accordance with BS EN 1364-2. Fire resistance period is inclusive of both fire integrity and fire insulation. Fire resistance performance must be reviewed against Knauf specifications and standard details.

Note 1: System that require fire resistance and/or acoustic sound insulation performance must have all outer joints taped and filled in accordance with Knauf recommendations. Systems are tested as imperforate.

Note 2: For substrate fixings, approved fixings are required to meet performance constraint. Site design team to agree the suitability of design and method of installation suitability for the project.

Knauf Metal Furring (MF) Suspended Ceilings (EN Compliance)

Knauf Plasterboard	Fixing Method	Layers to underside of Knauf MF Ceiling Framework	Thickness (mm)	Knauf Insulation RocksilK RS45 (mm) within ceiling void	System Code	Fire Resistance Period ¹
Wallboard	Fixed to underside of Knauf MF Ceiling	1	12.5	0	MF-1-12.5-WB-0	Not tested
Wallboard	Fixed to underside of Knauf MF Ceiling	1	15	0	MF-1-15-WB-0	Not tested
Moisture Panel	Fixed to underside of Knauf MF Ceiling	1	12.5	0	MF-1-12.5-MP-0	Not tested
Moisture Panel	Fixed to underside of Knauf MF Ceiling	1	15	0	MF-1-15-MP-0	Not tested
Soundshield Plus	Fixed to underside of Knauf MF Ceiling	1	12.5	0	MF-1-12.5-SSP-0	Not tested
Soundshield Plus	Fixed to underside of Knauf MF Ceiling	1	15	0	MF-1-15-SSP-0	Not tested
Fire Panel	Fixed to underside of Knauf MF Ceiling	2	12.5	0	MF-2-12.5-FP-0	30
Fire Panel	Fixed to underside of Knauf MF Ceiling	2	15	30	MF-2-15-FP-30RS	60
Wallboard	Fixed to underside of Knauf MF Ceiling	2	12.5	30	MF-2-12.5-WB-30RS	30
Moisture Panel	Fixed to underside of Knauf MF Ceiling	2	12.5	30	MF-2-12.5-MP-30RS	30

1. Fire resistance period: Tested in accordance with BS EN 1364-2. Fire resistance period is inclusive of both fire integrity and fire insulation. Fire resistance performance must be reviewed against Knauf specifications and standard details. Systems that denote N/A indicate that system has not been fire resistance tested.

Note 1. System that require fire resistance and/or acoustic sound insulation performance must have all outer joints taped and filled in accordance with Knauf recommendations. Systems are tested as imperforate.

Note 2: For substrate fixings, approved fixings are required to meet performance constraint. Site design team to agree the suitability of design and method of installation suitability for the project.

BS COMPLIANCE SPECIFICATION TABLES

Our systems

- **Knauf Performer Partition Systems**
 - Knauf Wallboard Solutions
 - Knauf Moisture Panel Solutions
 - Knauf Fire Panel Solutions
 - Knauf Soundshield Plus Solutions
 - Knauf Performance Plus Solutions
- **Knauf Performer – 'MW' Acoustic Studs**
- **Knauf Performer – Resilient Bar**
- **Knauf AQUAPANEL® Interior System**
- **Knauf Isolator (Twin Frame) Partitions**
- **Knauf Isolator (Twin Frame) Partitions - Hybrid**
- **Knauf Shaftwall**
- **Knauf 'I' Stud Linings: Fire Resistance Performance Systems**
- **Knauf 'I' Stud Linings: Non-Resistance Performance Systems**
- **Knauf Smokeshaft**
- **Knauf Horizontal Shaftwall – Ceiling System**
- **Knauf Metal Furring (MF) Suspended Ceiling Systems**

Knauf Performer - Wallboard (BS Compliance)



Got a question? Email our Technical Service on technical-uk@knauf.com or call 0800 521050 (option 2)

50mm Stud Solutions

Knauf Stud depth and gauge (mm)	Knauf Plasterboard layers to each side of Knauf Stud (no)	Thickness of Knauf Plasterboard (mm)	Knauf Plasterboard	Knauf Insulation Acoustic Roll - Cavity Insulation (mm)	System width (mm) excluding finishes	System code & Maximum height ¹ (mm) @ 600mm centres	System code & Maximum height ¹ (mm) @ 400mm centres	System code & Maximum height ¹ (mm) @ 300mm centres	Fire resistance period ² (minutes)	Acoustic Sound Insulation ³ (dB Rw)	Deflection allowance (mm)	Deflection head arrangement			
50'C Stud (0.55)	1	12.5	Wallboard	Non Insulated	77	BS-PC-50-055-6-1-12.5-WB-0	3000	BS-PC-50-055-4-1-12.5-WB-0	3200	BS-PC-50-055-3-1-12.5-WB-0	3400	NA	34	-25	Figure 1
	1	12.5	Wallboard	25	77	BS-PC-50-055-6-1-12.5-WB-25	3000	BS-PC-50-055-4-1-12.5-WB-25	3200	BS-PC-50-055-3-1-12.5-WB-25	3400	30	42	-25	Figure 3
	1	15	Wallboard	Non Insulated	82	BS-PC-50-055-6-1-15-WB-0	3100	BS-PC-50-055-4-1-15-WB-0	3300	BS-PC-50-055-3-1-15-WB-0	3500	30	36	-25	Figure 1
	1	15	Wallboard	25	82	BS-PC-50-055-6-1-15-WB-25	3100	BS-PC-50-055-4-1-15-WB-25	3300	BS-PC-50-055-3-1-15-WB-25	3500	Not Tested	42	-25	Figure 3
	2	12.5	Wallboard	Non Insulated	102	BS-PC-50-055-6-2-12.5-WB-0	3700	BS-PC-50-055-4-2-12.5-WB-0	3800	BS-PC-50-055-3-2-12.5-WB-0	4000	60	42	-25	Figure 2
	2	12.5	Wallboard	25	102	BS-PC-50-055-6-2-12.5-WB-25	3700	BS-PC-50-055-4-2-12.5-WB-25	3800	BS-PC-50-055-3-2-12.5-WB-25	4000	60	49	-25	Figure 4
	2	15	Wallboard	Non Insulated	112	BS-PC-50-055-6-2-15-WB-0	3900	BS-PC-50-055-4-2-15-WB-0	4000	BS-PC-50-055-3-2-15-WB-0	4200	60	45	-25	Figure 2
	2	15	Wallboard	25	112	BS-PC-50-055-6-2-15-WB-25	3900	BS-PC-50-055-4-2-15-WB-25	4000	BS-PC-50-055-3-2-15-WB-25	4200	Not Tested	51	-25	Figure 4

70mm Stud Solutions

Knauf Stud depth and gauge (mm)	Knauf Plasterboard layers to each side of Knauf Stud (no)	Thickness of Knauf Plasterboard (mm)	Knauf Plasterboard	Knauf Insulation Acoustic Roll - Cavity Insulation (mm)	System width (mm) excluding finishes	System code & Maximum height ¹ (mm) @ 600mm centres	System code & Maximum height ¹ (mm) @ 400mm centres	System code & Maximum height ¹ (mm) @ 300mm centres	Fire resistance period ² (minutes)	Acoustic Sound Insulation ³ (dB Rw)	Deflection allowance (mm)	Deflection head arrangement			
70'C Stud (0.55)	1	12.5	Wallboard	Non Insulated	77	BS-PC-70-055-6-1-12.5-WB-0	3600	BS-PC-70-055-4-1-12.5-WB-0	3900	BS-PC-70-055-3-1-12.5-WB-0	4200	NA	35	-25	Figure 1
	1	12.5	Wallboard	Non Insulated	77	BS-PC-70-055-6-1-12.5-WB-0	3600	BS-PC-70-055-4-1-12.5-WB-0	3900	BS-PC-70-055-3-1-12.5-WB-0	4200	NA	35	-50	Figure 5
	1	12.5	Wallboard	25	77	BS-PC-70-055-6-1-12.5-WB-25	3600	BS-PC-70-055-4-1-12.5-WB-25	3900	BS-PC-70-055-3-1-12.5-WB-25	4200	30	42	-25	Figure 3
	1	12.5	Wallboard	25	77	BS-PC-70-055-6-1-12.5-WB-25	3600	BS-PC-70-055-4-1-12.5-WB-25	3900	BS-PC-70-055-3-1-12.5-WB-25	4200	30	42	-50	Figure 7
	1	15	Wallboard	Non Insulated	82	BS-PC-70-055-6-1-15-WB-0	4000	BS-PC-70-055-4-1-15-WB-0	4300	BS-PC-70-055-3-1-15-WB-0	4500	30	37	-25	Figure 1
	1	15	Wallboard	Non Insulated	82	BS-PC-70-055-6-1-15-WB-0	4000	BS-PC-70-055-4-1-15-WB-0	4300	BS-PC-70-055-3-1-15-WB-0	4500	30	27	-50	Figure 5
	1	15	Wallboard	25	82	BS-PC-70-055-6-1-15-WB-25	4000	BS-PC-70-055-4-1-15-WB-25	4300	BS-PC-70-055-3-1-15-WB-25	4500	30	43	-25	Figure 3
	1	15	Wallboard	25	82	BS-PC-70-055-6-1-15-WB-25	4000	BS-PC-70-055-4-1-15-WB-25	4300	BS-PC-70-055-3-1-15-WB-25	4500	30	43	-50	Figure 7
	2	12.5	Wallboard	Non Insulated	102	BS-PC-70-055-6-2-12.5-WB-0	4500	BS-PC-70-055-4-2-12.5-WB-0	4700	BS-PC-70-055-3-2-12.5-WB-0	4900	60	43	-25	Figure 2
	2	12.5	Wallboard	Non Insulated	102	BS-PC-70-055-6-2-12.5-WB-0	4500	BS-PC-70-055-4-2-12.5-WB-0	4700	BS-PC-70-055-3-2-12.5-WB-0	4900	60	43	-50	Figure 6
	2	12.5	Wallboard	25	102	BS-PC-70-055-6-2-12.5-WB-25	4500	BS-PC-70-055-4-2-12.5-WB-25	4700	BS-PC-70-055-3-2-12.5-WB-25	4900	60	52	-25	Figure 4
	2	12.5	Wallboard	25	102	BS-PC-70-055-6-2-12.5-WB-25	4500	BS-PC-70-055-4-2-12.5-WB-25	4700	BS-PC-70-055-3-2-12.5-WB-25	4900	60	52	-50	Figure 8
	2	15	Wallboard	Non Insulated	112	BS-PC-70-055-6-2-15-WB-0	4800	BS-PC-70-055-4-2-15-WB-0	5000	BS-PC-70-055-3-2-15-WB-0	5200	60	46	-25	Figure 2
	2	15	Wallboard	Non Insulated	112	BS-PC-70-055-6-2-15-WB-0	4800	BS-PC-70-055-4-2-15-WB-0	5000	BS-PC-70-055-3-2-15-WB-0	5200	60	46	-50	Figure 6
	2	15	Wallboard	25	112	BS-PC-70-055-6-2-15-WB-25	4800	BS-PC-70-055-4-2-15-WB-25	5000	BS-PC-70-055-3-2-15-WB-25	5200	60	54	-25	Figure 4
	2	15	Wallboard	25	112	BS-PC-70-055-6-2-15-WB-25	4800	BS-PC-70-055-4-2-15-WB-25	5000	BS-PC-70-055-3-2-15-WB-25	5200	60	54	-50	Figure 8

1. **Maximum height for BS Compliance Systems:** The stated maximum height figure is based on the maximum cold state height, calculated to limiting deflection of L/240 @ 200 Pascals.
 2. **Fire resistance period:** Tested in accordance with BS EN 1364-1. Fire resistance period is inclusive of fire integrity and fire insulation (EI). Fire resistance performance must be reviewed against Knauf specifications and standard details.
 3. **Acoustic sound insulation:** Tested or assessed in accordance with BS EN ISO 10140-1 and BS EN 10140-2. Important - Acoustic Sound Insulation Performance based on Knauf studs at 600mm centres and non-deflection arrangement. Systems that are fire resistance and / or offering acoustic sound performance must have all outer joints taped and filled in accordance with Knauf recommendations. Systems are tested as imperforate.

Knauf Performer - Wallboard (BS Compliance)



Got a question? Email our Technical Service on technical-uk@knauf.com or call 0800 521050 (option 2)

92mm Stud Solutions

Knauf Stud depth and gauge (mm)	Knauf Plasterboard layers to each side of Knauf Stud (no)	Thickness of Knauf Plasterboard (mm)	Knauf Plasterboard	Knauf Insulation Acoustic Roll - Cavity Insulation (mm)	System width (mm) excluding finishes	System code & Maximum height ¹ (mm) @ 600mm centres	System code & Maximum height ¹ (mm) @ 400mm centres	System code & Maximum height ¹ (mm) @ 300mm centres	Fire resistance period ² (minutes)	Acoustic Sound Insulation ³ (dB Rw)	Deflection allowance (mm)	Deflection head arrangement			
92'C Stud (0.70)	1	12.5	Wallboard	Non Insulated	119	BS-PC-92-070-6-1-12.5-WB-0	4900	BS-PC-92-070-4-1-12.5-WB-0	5300	BS-PC-92-070-3-1-12.5-WB-0	5600	NA	35	-25	Figure 1
	1	12.5	Wallboard	Non Insulated	119	BS-PC-92-070-6-1-12.5-WB-0	4900	BS-PC-92-070-4-1-12.5-WB-0	5300	BS-PC-92-070-3-1-12.5-WB-0	5600	NA	35	-50	Figure 5
	1	12.5	Wallboard	25	119	BS-PC-92-070-6-1-12.5-WB-25	4900	BS-PC-92-070-4-1-12.5-WB-25	5300	BS-PC-92-070-3-1-12.5-WB-25	5600	30	42	-25	Figure 3
	1	12.5	Wallboard	25	119	BS-PC-92-070-6-1-12.5-WB-25	4900	BS-PC-92-070-4-1-12.5-WB-25	5300	BS-PC-92-070-3-1-12.5-WB-25	5600	30	42	-50	Figure 7
	1	15	Wallboard	Non Insulated	124	BS-PC-92-070-6-1-15-WB-0	5100	BS-PC-92-070-4-1-15-WB-0	5400	BS-PC-92-070-3-1-15-WB-0	5800	30	37	-25	Figure 1
	1	15	Wallboard	Non Insulated	124	BS-PC-92-070-6-1-15-WB-0	5100	BS-PC-92-070-4-1-15-WB-0	5400	BS-PC-92-070-3-1-15-WB-0	5800	30	37	-50	Figure 5
	1	15	Wallboard	25	124	BS-PC-92-070-6-1-15-WB-25	5100	BS-PC-92-070-4-1-15-WB-25	5400	BS-PC-92-070-3-1-15-WB-25	5800	30	43	-25	Figure 3
	1	15	Wallboard	25	124	BS-PC-92-070-6-1-15-WB-25	5100	BS-PC-92-070-4-1-15-WB-25	5400	BS-PC-92-070-3-1-15-WB-25	5800	30	43	-50	Figure 7
	2	12.5	Wallboard	Non Insulated	144	BS-PC-92-070-6-2-12.5-WB-0	5700	BS-PC-92-070-4-2-12.5-WB-0	6100	BS-PC-92-070-3-2-12.5-WB-0	6300	60	43	-25	Figure 2
	2	12.5	Wallboard	Non Insulated	144	BS-PC-92-070-6-2-12.5-WB-0	5700	BS-PC-92-070-4-2-12.5-WB-0	6100	BS-PC-92-070-3-2-12.5-WB-0	6300	60	43	-50	Figure 6
	2	12.5	Wallboard	25	144	BS-PC-92-070-6-2-12.5-WB-25	5700	BS-PC-92-070-4-2-12.5-WB-25	6100	BS-PC-92-070-3-2-12.5-WB-25	6300	60	52	-25	Figure 4
	2	12.5	Wallboard	25	144	BS-PC-92-070-6-2-12.5-WB-25	5700	BS-PC-92-070-4-2-12.5-WB-25	6100	BS-PC-92-070-3-2-12.5-WB-25	6300	60	52	-50	Figure 8
	2	15	Wallboard	Non Insulated	154	BS-PC-92-070-6-2-15-WB-0	6000	BS-PC-92-070-4-2-15-WB-0	6300	BS-PC-92-070-3-2-15-WB-0	6600	60	46	-25	Figure 2
	2	15	Wallboard	Non Insulated	154	BS-PC-92-070-6-2-15-WB-0	6000	BS-PC-92-070-4-2-15-WB-0	6300	BS-PC-92-070-3-2-15-WB-0	6600	60	46	-50	Figure 6
	2	15	Wallboard	25	154	BS-PC-92-070-6-2-15-WB-25	6000	BS-PC-92-070-4-2-15-WB-25	6300	BS-PC-92-070-3-2-15-WB-25	6600	60	54	-25	Figure 4
	2	15	Wallboard	25	154	BS-PC-92-070-6-2-15-WB-25	6000	BS-PC-92-070-4-2-15-WB-25	6300	BS-PC-92-070-3-2-15-WB-25	6600	60	54	-50	Figure 8

146mm Stud Solutions

Knauf Stud depth and gauge (mm)	Knauf Plasterboard layers to each side of Knauf Stud (no)	Thickness of Knauf Plasterboard (mm)	Knauf Plasterboard	Knauf Insulation Acoustic Roll - Cavity Insulation (mm)	System width (mm) excluding finishes	System code & Maximum height ¹ (mm) @ 600mm centres	System code & Maximum height ¹ (mm) @ 400mm centres	System code & Maximum height ¹ (mm) @ 300mm centres	Fire resistance period ² (minutes)	Acoustic Sound Insulation ³ (dB Rw)	Deflection allowance (mm)	Deflection head arrangement			
146'C Stud (0.55)	1	12.5	Wallboard	Non Insulated	173	BS-PC-146-055-6-1-12.5-WB-0	5600	BS-PC-146-055-4-1-12.5-WB-0	6400	BS-PC-146-055-3-1-12.5-WB-0	7000	NA	35	-25	Figure 1
	1	12.5	Wallboard	Non Insulated	173	BS-PC-146-055-6-1-12.5-WB-0	5600	BS-PC-146-055-4-1-12.5-WB-0	6400	BS-PC-146-055-3-1-12.5-WB-0	7000	NA	35	-50	Figure 5
	1	12.5	Wallboard	25	173	BS-PC-146-055-6-1-12.5-WB-25	5600	BS-PC-146-055-4-1-12.5-WB-25	6400	BS-PC-146-055-3-1-12.5-WB-25	7000	30	42	-25	Figure 3
	1	12.5	Wallboard	25	173	BS-PC-146-055-6-1-12.5-WB-25	5600	BS-PC-146-055-4-1-12.5-WB-25	6400	BS-PC-146-055-3-1-12.5-WB-25	7000	30	42	-50	Figure 7
	1	15	Wallboard	Non Insulated	178	BS-PC-146-055-6-1-15-WB-0	5800	BS-PC-146-055-4-1-15-WB-0	6700	BS-PC-146-055-3-1-15-WB-0	7200	30	37	-25	Figure 1
	1	15	Wallboard	Non Insulated	178	BS-PC-146-055-6-1-15-WB-0	5800	BS-PC-146-055-4-1-15-WB-0	6700	BS-PC-146-055-3-1-15-WB-0	7200	30	37	-50	Figure 5
	1	15	Wallboard	25	178	BS-PC-146-055-6-1-15-WB-25	5800	BS-PC-146-055-4-1-15-WB-25	6700	BS-PC-146-055-3-1-15-WB-25	7200	30	43	-25	Figure 3
	1	15	Wallboard	25	178	BS-PC-146-055-6-1-15-WB-25	5800	BS-PC-146-055-4-1-15-WB-25	6700	BS-PC-146-055-3-1-15-WB-25	7200	30	43	-50	Figure 7
	2	12.5	Wallboard	Non Insulated	198	BS-PC-146-055-6-2-12.5-WB-0	6300	BS-PC-146-055-4-2-12.5-WB-0	7500	BS-PC-146-055-3-2-12.5-WB-0	7900	60	49	-25	Figure 2
	2	12.5	Wallboard	Non Insulated	198	BS-PC-146-055-6-2-12.5-WB-0	6300	BS-PC-146-055-4-2-12.5-WB-0	7500	BS-PC-146-055-3-2-12.5-WB-0	7900	60	49	-50	Figure 6
	2	12.5	Wallboard	25	198	BS-PC-146-055-6-2-12.5-WB-25	6300	BS-PC-146-055-4-2-12.5-WB-25	7500	BS-PC-146-055-3-2-12.5-WB-25	7900	60	53	-25	Figure 4
	2	12.5	Wallboard	25	198	BS-PC-146-055-6-2-12.5-WB-25	6300	BS-PC-146-055-4-2-12.5-WB-25	7500	BS-PC-146-055-3-2-12.5-WB-25	7900	60	53	-50	Figure 8
	2	15	Wallboard	Non Insulated	208	BS-PC-146-055-6-2-15-WB-0	6600	BS-PC-146-055-4-2-15-WB-0	7900	BS-PC-146-055-3-2-15-WB-0	8300	60	50	-25	Figure 2
	2	15	Wallboard	Non Insulated	208	BS-PC-146-055-6-2-15-WB-0	6600	BS-PC-146-055-4-2-15-WB-0	7900	BS-PC-146-055-3-2-15-WB-0	8300	60	50	-50	Figure 6
	2	15	Wallboard	25	208	BS-PC-146-055-6-2-15-WB-25	6600	BS-PC-146-055-4-2-15-WB-25	7900	BS-PC-146-055-3-2-15-WB-25	8300	60	54	-25	Figure 4
	2	15	Wallboard	25	208	BS-PC-146-055-6-2-15-WB-25	6600	BS-PC-146-055-4-2-15-WB-25	7900	BS-PC-146-055-3-2-15-WB-25	8300	60	54	-50	Figure 8

1. **Maximum height for BS Compliance Systems:** The stated maximum height figure is based on the maximum cold state height, calculated to limiting deflection of L/240 @ 200 Pascals.
 2. **Fire resistance period:** Tested in accordance with BS EN 1364-1. Fire resistance period is inclusive of fire integrity and fire insulation (EI). Fire resistance performance must be reviewed against Knauf specifications and standard details.
 3. **Acoustic sound insulation:** Tested or assessed in accordance with BS EN ISO 10140-1 and BS EN 10140-2. Important - Acoustic Sound Insulation Performance based on Knauf studs at 600mm centres and non-deflection arrangement. Systems that are fire resistance and / or offering acoustic sound performance must have all outer joints taped and filled in accordance with Knauf recommendations. Systems are tested as imperforate.

Knauf Performer - Moisture Panel (BS Compliance)



Got a question? Email our Technical Service on technical-uk@knauf.com or call 0800 521050 (option 2)

50mm Stud Solutions

Knauf Stud depth and gauge (mm)	Knauf Plasterboard layers to each side of Knauf Stud (no)	Thickness of Knauf Plasterboard (mm)	Knauf Plasterboard	Knauf Insulation Acoustic Roll - Cavity Insulation (mm)	System width (mm) excluding finishes	System code & Maximum height ¹ (mm) @ 600mm centres	System code & Maximum height ¹ (mm) @ 400mm centres	System code & Maximum height ¹ (mm) @ 300mm centres	Fire resistance period ² (minutes)	Acoustic Sound Insulation ³ (dB Rw)	Deflection allowance (mm)	Deflection head arrangement			
50'C Stud (0.55)	1	12.5	Moisture Panel	Non Insulated	77	BS-PC-50-055-6-1-12.5-MP-0	3000	BS-PC-50-055-4-1-12.5-MP-0	3200	BS-PC-50-055-3-1-12.5-MP-0	3400	NA	34	-25	Figure 1
	1	12.5	Moisture Panel	25	77	BS-PC-50-055-6-1-12.5-MP-25	3000	BS-PC-50-055-4-1-12.5-MP-25	3200	BS-PC-50-055-3-1-12.5-MP-25	3400	30	42	-25	Figure 3
	1	15	Moisture Panel	Non Insulated	82	BS-PC-50-055-6-1-15-MP-0	3100	BS-PC-50-055-4-1-15-MP-0	3300	BS-PC-50-055-3-1-15-MP-0	3500	30	36	-25	Figure 1
	1	15	Moisture Panel	25	82	BS-PC-50-055-6-1-15-MP-25	3100	BS-PC-50-055-4-1-15-MP-25	3300	BS-PC-50-055-3-1-15-MP-25	3500	Not Tested	42	-25	Figure 3
	2	12.5	Moisture Panel	Non Insulated	102	BS-PC-50-055-6-2-12.5-MP-0	3700	BS-PC-50-055-4-2-12.5-MP-0	3800	BS-PC-50-055-3-2-12.5-MP-0	4000	60	42	-25	Figure 2
	2	12.5	Moisture Panel	25	102	BS-PC-50-055-6-2-12.5-MP-25	3700	BS-PC-50-055-4-2-12.5-MP-25	3800	BS-PC-50-055-3-2-12.5-MP-25	4000	Not Tested	49	-25	Figure 4
	2	15	Moisture Panel	Non Insulated	112	BS-PC-50-055-6-2-15-MP-0	3900	BS-PC-50-055-4-2-15-MP-0	4000	BS-PC-50-055-3-2-15-MP-0	4200	60	45	-25	Figure 2
	2	15	Moisture Panel	25	112	BS-PC-50-055-6-2-15-MP-25	3900	BS-PC-50-055-4-2-15-MP-25	4000	BS-PC-50-055-3-2-15-MP-25	4200	Not Tested	51	-25	Figure 4

70mm Stud Solutions

Knauf Stud depth and gauge (mm)	Knauf Plasterboard layers to each side of Knauf Stud (no)	Thickness of Knauf Plasterboard (mm)	Knauf Plasterboard	Knauf Insulation Acoustic Roll - Cavity Insulation (mm)	System width (mm) excluding finishes	System code & Maximum height ¹ (mm) @ 600mm centres	System code & Maximum height ¹ (mm) @ 400mm centres	System code & Maximum height ¹ (mm) @ 300mm centres	Fire resistance period ² (minutes)	Acoustic Sound Insulation ³ (dB Rw)	Deflection allowance (mm)	Deflection head arrangement			
70'C Stud (0.55)	1	12.5	Moisture Panel	Non Insulated	97	BS-PC-70-055-6-1-12.5-MP-0	3600	BS-PC-70-055-4-1-12.5-MP-0	3900	BS-PC-70-055-3-1-12.5-MP-0	4200	NA	35	-25	Figure 1
	1	12.5	Moisture Panel	Non Insulated	97	BS-PC-70-055-6-1-12.5-MP-0	3600	BS-PC-70-055-4-1-12.5-MP-0	3900	BS-PC-70-055-3-1-12.5-MP-0	4200	NA	35	-50	Figure 5
	1	12.5	Moisture Panel	25	97	BS-PC-70-055-6-1-12.5-MP-25	3600	BS-PC-70-055-4-1-12.5-MP-25	3900	BS-PC-70-055-3-1-12.5-MP-25	4200	30	42	-25	Figure 3
	1	12.5	Moisture Panel	25	97	BS-PC-70-055-6-1-12.5-MP-25	3600	BS-PC-70-055-4-1-12.5-MP-25	3900	BS-PC-70-055-3-1-12.5-MP-25	4200	30	42	-50	Figure 7
	1	15	Moisture Panel	Non Insulated	102	BS-PC-70-055-6-1-15-MP-0	4000	BS-PC-70-055-4-1-15-MP-0	4300	BS-PC-70-055-3-1-15-MP-0	4500	30	37	-25	Figure 1
	1	15	Moisture Panel	Non Insulated	102	BS-PC-70-055-6-1-15-MP-0	4000	BS-PC-70-055-4-1-15-MP-0	4300	BS-PC-70-055-3-1-15-MP-0	4500	30	37	-50	Figure 5
	1	15	Moisture Panel	25	102	BS-PC-70-055-6-1-15-MP-25	4000	BS-PC-70-055-4-1-15-MP-25	4300	BS-PC-70-055-3-1-15-MP-25	4500	30	43	-25	Figure 3
	1	15	Moisture Panel	25	102	BS-PC-70-055-6-1-15-MP-25	4000	BS-PC-70-055-4-1-15-MP-25	4300	BS-PC-70-055-3-1-15-MP-25	4500	30	43	-50	Figure 7
	2	12.5	Moisture Panel	Non Insulated	122	BS-PC-70-055-6-2-12.5-MP-0	4500	BS-PC-70-055-4-2-12.5-MP-0	4700	BS-PC-70-055-3-2-12.5-MP-0	4900	60	43	-25	Figure 2
	2	12.5	Moisture Panel	Non Insulated	122	BS-PC-70-055-6-2-12.5-MP-0	4500	BS-PC-70-055-4-2-12.5-MP-0	4700	BS-PC-70-055-3-2-12.5-MP-0	4900	60	43	-50	Figure 6
	2	12.5	Moisture Panel	25	122	BS-PC-70-055-6-2-12.5-MP-25	4500	BS-PC-70-055-4-2-12.5-MP-25	4700	BS-PC-70-055-3-2-12.5-MP-25	4900	Not Tested	52	-25	Figure 4
	2	12.5	Moisture Panel	25	122	BS-PC-70-055-6-2-12.5-MP-25	4500	BS-PC-70-055-4-2-12.5-MP-25	4700	BS-PC-70-055-3-2-12.5-MP-25	4900	Not Tested	52	-50	Figure 8
	2	15	Moisture Panel	Non Insulated	132	BS-PC-70-055-6-2-15-MP-0	4800	BS-PC-70-055-4-2-15-MP-0	5000	BS-PC-70-055-3-2-15-MP-0	5200	30*	46	-25	Figure 2
	2	15	Moisture Panel	Non Insulated	132	BS-PC-70-055-6-2-15-MP-0	4800	BS-PC-70-055-4-2-15-MP-0	5000	BS-PC-70-055-3-2-15-MP-0	5200	30*	46	-50	Figure 6
	2	15	Moisture Panel	25	132	BS-PC-70-055-6-2-15-MP-25	4800	BS-PC-70-055-4-2-15-MP-25	5000	BS-PC-70-055-3-2-15-MP-25	5200	30*	54	-25	Figure 4
	2	15	Moisture Panel	25	132	BS-PC-70-055-6-2-15-MP-25	4800	BS-PC-70-055-4-2-15-MP-25	5000	BS-PC-70-055-3-2-15-MP-25	5200	30*	54	-50	Figure 8

*System performance based on single layer system

1. Maximum height for BS Compliance Systems: The stated maximum height figure is based on the maximum cold state height, calculated to limiting deflection of L/240 @ 200 Pascals.
2. Fire resistance period: Tested in accordance with BS EN 1364-1. Fire resistance period is inclusive of fire integrity and fire insulation (EI). Fire resistance performance must be reviewed against Knauf specifications and standard details.
3. Acoustic sound insulation: Tested or assessed in accordance with BS EN ISO 10140-1 and BS EN 10140-2. Important - Acoustic Sound Insulation Performance based on Knauf studs at 600mm centres and non-deflection arrangement. Systems that are fire resistance and / or offering acoustic sound performance must have all outer joints taped and filled in accordance with Knauf recommendations. Systems are tested as imperforate.

Knauf Performer - Moisture Panel (BS Compliance)



Got a question? Email our Technical Service on technical-uk@knauf.com or call 0800 521050 (option 2)

92mm Stud Solutions

Knauf Stud depth and gauge (mm)	Knauf Plasterboard layers to each side of Knauf Stud (no)	Thickness of Knauf Plasterboard (mm)	Knauf Plasterboard	Knauf Insulation Acoustic Roll - Cavity Insulation (mm)	System width (mm) excluding finishes	System code & Maximum height ¹ (mm) @ 600mm centres	System code & Maximum height ¹ (mm) @ 400mm centres	System code & Maximum height ¹ (mm) @ 300mm centres	Fire resistance period ² (minutes)	Acoustic Sound Insulation ³ (dB Rw)	Deflection allowance (mm)	Deflection head arrangement			
92'C Stud (0.70)	1	12.5	Moisture Panel	Non Insulated	119	BS-PC-92-070-6-1-12.5-MP-0	4900	BS-PC-92-070-4-1-12.5-MP-0	5300	BS-PC-92-070-3-1-12.5-MP-0	5600	NA	35	-25	Figure 1
	1	12.5	Moisture Panel	Non Insulated	119	BS-PC-92-070-6-1-12.5-MP-0	4900	BS-PC-92-070-4-1-12.5-MP-0	5300	BS-PC-92-070-3-1-12.5-MP-0	5600	NA	35	-50	Figure 5
	1	12.5	Moisture Panel	25	119	BS-PC-92-070-6-1-12.5-MP-25	4900	BS-PC-92-070-4-1-12.5-MP-25	5300	BS-PC-92-070-3-1-12.5-MP-25	5600	30	42	-25	Figure 3
	1	12.5	Moisture Panel	25	119	BS-PC-92-070-6-1-12.5-MP-25	4900	BS-PC-92-070-4-1-12.5-MP-25	5300	BS-PC-92-070-3-1-12.5-MP-25	5600	30	42	-50	Figure 7
	1	15	Moisture Panel	Non Insulated	124	BS-PC-92-070-6-1-15-MP-0	5100	BS-PC-92-070-4-1-15-MP-0	5400	BS-PC-92-070-3-1-15-MP-0	5800	30	37	-25	Figure 1
	1	15	Moisture Panel	Non Insulated	124	BS-PC-92-070-6-1-15-MP-0	5100	BS-PC-92-070-4-1-15-MP-0	5400	BS-PC-92-070-3-1-15-MP-0	5800	30	37	-50	Figure 5
	1	15	Moisture Panel	25	124	BS-PC-92-070-6-1-15-MP-25	5100	BS-PC-92-070-4-1-15-MP-25	5400	BS-PC-92-070-3-1-15-MP-25	5800	30	43	-25	Figure 3
	1	15	Moisture Panel	25	124	BS-PC-92-070-6-1-15-MP-25	5100	BS-PC-92-070-4-1-15-MP-25	5400	BS-PC-92-070-3-1-15-MP-25	5800	30	43	-50	Figure 7
	2	12.5	Moisture Panel	Non Insulated	144	BS-PC-92-070-6-2-12.5-MP-0	5700	BS-PC-92-070-4-2-12.5-MP-0	6100	BS-PC-92-070-3-2-12.5-MP-0	6300	60	43	-25	Figure 2
	2	12.5	Moisture Panel	Non Insulated	144	BS-PC-92-070-6-2-12.5-MP-0	5700	BS-PC-92-070-4-2-12.5-MP-0	6100	BS-PC-92-070-3-2-12.5-MP-0	6300	60	43	-50	Figure 6
	2	12.5	Moisture Panel	25	144	BS-PC-92-070-6-2-12.5-MP-25	5700	BS-PC-92-070-4-2-12.5-MP-25	6100	BS-PC-92-070-3-2-12.5-MP-25	6300	Not Tested	52	-25	Figure 4
	2	12.5	Moisture Panel	25	144	BS-PC-92-070-6-2-12.5-MP-25	5700	BS-PC-92-070-4-2-12.5-MP-25	6100	BS-PC-92-070-3-2-12.5-MP-25	6300	Not tested	52	-50	Figure 8
	2	15	Moisture Panel	Non Insulated	154	BS-PC-92-070-6-2-15-MP-0	6000	BS-PC-92-070-4-2-15-MP-0	6300	BS-PC-92-070-3-2-15-MP-0	6600	30*	46	-25	Figure 2
	2	15	Moisture Panel	Non Insulated	154	BS-PC-92-070-6-2-15-MP-0	6000	BS-PC-92-070-4-2-15-MP-0	6300	BS-PC-92-070-3-2-15-MP-0	6600	30*	46	-50	Figure 6
	2	15	Moisture Panel	25	154	BS-PC-92-070-6-2-15-MP-25	6000	BS-PC-92-070-4-2-15-MP-25	6300	BS-PC-92-070-3-2-15-MP-25	6600	30*	54	-25	Figure 4
	2	15	Moisture Panel	25	154	BS-PC-92-070-6-2-15-MP-25	6000	BS-PC-92-070-4-2-15-MP-25	6300	BS-PC-92-070-3-2-15-MP-25	6600	30*	54	-50	Figure 8

146mm Stud Solutions

Knauf Stud depth and gauge (mm)	Knauf Plasterboard layers to each side of Knauf Stud (no)	Thickness of Knauf Plasterboard (mm)	Knauf Plasterboard	Knauf Insulation Acoustic Roll - Cavity Insulation (mm)	System width (mm) excluding finishes	System code & Maximum height ¹ (mm) @ 600mm centres	System code & Maximum height ¹ (mm) @ 400mm centres	System code & Maximum height ¹ (mm) @ 300mm centres	Fire resistance period ² (minutes)	Acoustic Sound Insulation ³ (dB Rw)	Deflection allowance (mm)	Deflection head arrangement			
146'C Stud (0.55)	1	12.5	Moisture Panel	Non Insulated	173	BS-PC-146-055-6-1-12.5-MP-0	5800	BS-PC-146-055-4-1-12.5-MP-0	6400	BS-PC-146-055-3-1-12.5-MP-0	7000	NA	35	-25	Figure 1
	1	12.5	Moisture Panel	Non Insulated	173	BS-PC-146-055-6-1-12.5-MP-0	5800	BS-PC-146-055-4-1-12.5-MP-0	6400	BS-PC-146-055-3-1-12.5-MP-0	7000	NA	35	-50	Figure 5
	1	12.5	Moisture Panel	25	173	BS-PC-146-055-6-1-12.5-MP-25	5800	BS-PC-146-055-4-1-12.5-MP-25	6400	BS-PC-146-055-3-1-12.5-MP-25	7000	30	42	-25	Figure 3
	1	12.5	Moisture Panel	25	173	BS-PC-146-055-6-1-12.5-MP-25	5800	BS-PC-146-055-4-1-12.5-MP-25	6400	BS-PC-146-055-3-1-12.5-MP-25	7000	30	42	-50	Figure 7
	1	15	Moisture Panel	Non Insulated	178	BS-PC-146-055-6-1-15-MP-0	6100	BS-PC-146-055-4-1-15-MP-0	6700	BS-PC-146-055-3-1-15-MP-0	7200	30	37	-25	Figure 1
	1	15	Moisture Panel	Non Insulated	178	BS-PC-146-055-6-1-15-MP-0	6100	BS-PC-146-055-4-1-15-MP-0	6700	BS-PC-146-055-3-1-15-MP-0	7200	30	37	-50	Figure 5
	1	15	Moisture Panel	25	178	BS-PC-146-055-6-1-15-MP-25	6100	BS-PC-146-055-4-1-15-MP-25	6700	BS-PC-146-055-3-1-15-MP-25	7200	30	43	-25	Figure 3
	1	15	Moisture Panel	25	178	BS-PC-146-055-6-1-15-MP-25	6100	BS-PC-146-055-4-1-15-MP-25	6700	BS-PC-146-055-3-1-15-MP-25	7200	30	43	-50	Figure 7
	2	12.5	Moisture Panel	Non Insulated	198	BS-PC-146-055-6-2-12.5-MP-0	7100	BS-PC-146-055-4-2-12.5-MP-0	7500	BS-PC-146-055-3-2-12.5-MP-0	7900	60	49	-25	Figure 2
	2	12.5	Moisture Panel	Non Insulated	198	BS-PC-146-055-6-2-12.5-MP-0	7100	BS-PC-146-055-4-2-12.5-MP-0	7500	BS-PC-146-055-3-2-12.5-MP-0	7900	60	49	-50	Figure 6
	2	12.5	Moisture Panel	25	198	BS-PC-146-055-6-2-12.5-MP-25	7100	BS-PC-146-055-4-2-12.5-MP-25	7500	BS-PC-146-055-3-2-12.5-MP-25	7900	Not Tested	53	-25	Figure 4
	2	12.5	Moisture Panel	25	198	BS-PC-146-055-6-2-12.5-MP-25	7100	BS-PC-146-055-4-2-12.5-MP-25	7500	BS-PC-146-055-3-2-12.5-MP-25	7900	Not tested	53	-50	Figure 8
	2	15	Moisture Panel	Non Insulated	208	BS-PC-146-055-6-2-15-MP-0	7500	BS-PC-146-055-4-2-15-MP-0	7900	BS-PC-146-055-3-2-15-MP-0	8300	30*	50	-25	Figure 2
	2	15	Moisture Panel	Non Insulated	208	BS-PC-146-055-6-2-15-MP-0	7500	BS-PC-146-055-4-2-15-MP-0	7900	BS-PC-146-055-3-2-15-MP-0	8300	30*	50	-50	Figure 6
	2	15	Moisture Panel	25	208	BS-PC-146-055-6-2-15-MP-25	7500	BS-PC-146-055-4-2-15-MP-25	7900	BS-PC-146-055-3-2-15-MP-25	8300	30*	54	-25	Figure 4
	2	15	Moisture Panel	25	208	BS-PC-146-055-6-2-15-MP-25	7500	BS-PC-146-055-4-2-15-MP-25	7900	BS-PC-146-055-3-2-15-MP-25	8300	30*	54	-50	Figure 8

*System performance based on single layer system

- Maximum height for BS Compliance Systems:** The stated maximum height figure is based on the maximum cold state height, calculated to limiting deflection of L/240 @ 200 Pascals.
- Fire resistance period:** Tested in accordance with BS EN 1364-1. Fire resistance period is inclusive of fire integrity and fire insulation (EI). Fire resistance performance must be reviewed against Knauf specifications and standard details.
- Acoustic sound insulation:** Tested or assessed in accordance with BS EN ISO 10140-1 and BS EN 10140-2. Important - Acoustic Sound Insulation Performance based on Knauf studs at 600mm centres and non-deflection arrangement. Systems that are fire resistance and / or offering acoustic sound performance must have all outer joints taped and filled in accordance with Knauf recommendations. Systems are tested as imperforate.

BS Compliance Specifications

Knauf Performer - Fire Panel (BS Compliance)



Got a question? Email our Technical Service on technical-uk@knauf.com or call 0800 521050 (option 2)

50mm Stud Solutions

Knauf Stud depth and gauge (mm)	Knauf Plasterboard layers to each side of Knauf Stud (no)	Thickness of Knauf Plasterboard (mm)	Knauf Plasterboard	Knauf Insulation Acoustic Roll - Cavity Insulation (mm)	System width (mm) excluding finishes	System code & Maximum height ¹ (mm) @ 600mm centres	System code & Maximum height ¹ (mm) @ 400mm centres	System code & Maximum height ¹ (mm) @ 300mm centres	Fire resistance period ² (minutes)	Acoustic Sound Insulation ³ (dB Rw)	Deflection allowance (mm)	Deflection head arrangement			
50'C Stud (0.55)	1	12.5	Fire Panel	Non Insulated	77	BS-PC-50-055-6-1-12.5-FP-0	3000	BS-PC-50-055-4-1-12.5-FP-0	3200	BS-PC-50-055-3-1-12.5-FP-0	3400	30	34	-25	Figure 1
	1	12.5	Fire Panel	25	77	BS-PC-50-055-6-1-12.5-FP-25	3000	BS-PC-50-055-4-1-12.5-FP-25	3200	BS-PC-50-055-3-1-12.5-FP-25	3400	30	42	-25	Figure 3
	1	15	Fire Panel	Non Insulated	82	BS-PC-50-055-6-1-15-FP-0	3100	BS-PC-50-055-4-1-15-FP-0	3300	BS-PC-50-055-3-1-15-FP-0	3500	30	36	-25	Figure 1
	1	15	Fire Panel	25	82	BS-PC-50-055-6-1-15-FP-25	3100	BS-PC-50-055-4-1-15-FP-25	3300	BS-PC-50-055-3-1-15-FP-25	3500	Not Tested	42	-25	Figure 3
	2	12.5	Fire Panel	Non Insulated	102	BS-PC-50-055-6-2-12.5-FP-0	3700	BS-PC-50-055-4-2-12.5-FP-0	3800	BS-PC-50-055-3-2-12.5-FP-0	4000	120	42	-25	Figure 13
	2	12.5	Fire Panel	25	102	BS-PC-50-055-6-2-12.5-FP-25	3700	BS-PC-50-055-4-2-12.5-FP-25	3800	BS-PC-50-055-3-2-12.5-FP-25	4000	Not Tested	49	-25	Figure 14
	2	15	Fire Panel	Non Insulated	112	BS-PC-50-055-6-2-15-FP-0	3900	BS-PC-50-055-4-2-15-FP-0	4000	BS-PC-50-055-3-2-15-FP-0	4200	120	45	-25	Figure 13
	2	15	Fire Panel	25	112	BS-PC-50-055-6-2-15-FP-25	3900	BS-PC-50-055-4-2-15-FP-25	4000	BS-PC-50-055-3-2-15-FP-25	4200	Not Tested	51	-25	Figure 14

70mm Stud Solutions

Knauf Stud depth and gauge (mm)	Knauf Plasterboard layers to each side of Knauf Stud (no)	Thickness of Knauf Plasterboard (mm)	Knauf Plasterboard	Knauf Insulation Acoustic Roll - Cavity Insulation (mm)	System width (mm) excluding finishes	System code & Maximum height ¹ (mm) @ 600mm centres	System code & Maximum height ¹ (mm) @ 400mm centres	System code & Maximum height ¹ (mm) @ 300mm centres	Fire resistance period ² (minutes)	Acoustic Sound Insulation ³ (dB Rw)	Deflection allowance (mm)	Deflection head arrangement			
70'C Stud (0.55)	1	12.5	Fire Panel	Non Insulated	97	BS-PC-70-055-6-1-12.5-FP-0	3600	BS-PC-70-055-4-1-12.5-FP-0	3900	BS-PC-70-055-3-1-12.5-FP-0	4200	30	35	-25	Figure 1
	1	12.5	Fire Panel	Non Insulated	97	BS-PC-70-055-6-1-12.5-FP-0	3600	BS-PC-70-055-4-1-12.5-FP-0	3900	BS-PC-70-055-3-1-12.5-FP-0	4200	30	35	-50	Figure 5
	1	12.5	Fire Panel	25	97	BS-PC-70-055-6-1-12.5-FP-25	3600	BS-PC-70-055-4-1-12.5-FP-25	3900	BS-PC-70-055-3-1-12.5-FP-25	4200	30	42	-25	Figure 3
	1	12.5	Fire Panel	25	97	BS-PC-70-055-6-1-12.5-FP-25	3600	BS-PC-70-055-4-1-12.5-FP-25	3900	BS-PC-70-055-3-1-12.5-FP-25	4200	30	42	-50	Figure 7
	1	15	Fire Panel	Non Insulated	102	BS-PC-70-055-6-1-15-FP-0	4000	BS-PC-70-055-4-1-15-FP-0	4300	BS-PC-70-055-3-1-15-FP-0	4500	60	37	-25	Figure 9
	1	15	Fire Panel	Non Insulated	102	BS-PC-70-055-6-1-15-FP-0	4000	BS-PC-70-055-4-1-15-FP-0	4300	BS-PC-70-055-3-1-15-FP-0	4500	60	37	-50	Figure 10
	1	15	Fire Panel	25	102	BS-PC-70-055-6-1-15-FP-25	4000	BS-PC-70-055-4-1-15-FP-25	4300	BS-PC-70-055-3-1-15-FP-25	4500	Not Tested	43	-25	Figure 3
	1	15	Fire Panel	25	102	BS-PC-70-055-6-1-15-FP-25	4000	BS-PC-70-055-4-1-15-FP-25	4300	BS-PC-70-055-3-1-15-FP-25	4500	Not Tested	43	-50	Figure 7
	2	12.5	Fire Panel	Non Insulated	122	BS-PC-70-055-6-2-12.5-FP-0	4500	BS-PC-70-055-4-2-12.5-FP-0	4700	BS-PC-70-055-3-2-12.5-FP-0	4900	120	43	-25	Figure 13
	2	12.5	Fire Panel	Non Insulated	122	BS-PC-70-055-6-2-12.5-FP-0	4500	BS-PC-70-055-4-2-12.5-FP-0	4700	BS-PC-70-055-3-2-12.5-FP-0	4900	120	43	-50	Figure 15
	2	12.5	Fire Panel	25	122	BS-PC-70-055-6-2-12.5-FP-25	4500	BS-PC-70-055-4-2-12.5-FP-25	4700	BS-PC-70-055-3-2-12.5-FP-25	4900	120	52	-25	Figure 14
	2	12.5	Fire Panel	25	122	BS-PC-70-055-6-2-12.5-FP-25	4500	BS-PC-70-055-4-2-12.5-FP-25	4700	BS-PC-70-055-3-2-12.5-FP-25	4900	120	52	-50	Figure 16
	2	15	Fire Panel	Non Insulated	132	BS-PC-70-055-6-2-15-FP-0	4800	BS-PC-70-055-4-2-15-FP-0	5000	BS-PC-70-055-3-2-15-FP-0	5200	120	46	-25	Figure 13
	2	15	Fire Panel	Non Insulated	132	BS-PC-70-055-6-2-15-FP-0	4800	BS-PC-70-055-4-2-15-FP-0	5000	BS-PC-70-055-3-2-15-FP-0	5200	120	46	-50	Figure 15
	2	15	Fire Panel	25	132	BS-PC-70-055-6-2-15-FP-25	4800	BS-PC-70-055-4-2-15-FP-25	5000	BS-PC-70-055-3-2-15-FP-25	5200	Not Tested	54	-25	Figure 14
	2	15	Fire Panel	25	132	BS-PC-70-055-6-2-15-FP-25	4800	BS-PC-70-055-4-2-15-FP-25	5000	BS-PC-70-055-3-2-15-FP-25	5200	Not Tested	54	-50	Figure 16

1. Maximum height for BS Compliance Systems: The stated maximum height figure is based on the maximum cold state height, calculated to limiting deflection of L/240 @ 200 Pascals.
2. Fire resistance period: Tested in accordance with BS EN 1364-1. Fire resistance period is inclusive of fire integrity and fire insulation (EI). Fire resistance performance must be reviewed against Knauf specifications and standard details.
3. Acoustic sound insulation: Tested or assessed in accordance with BS EN ISO 10140-1 and BS EN 10140-2. Important - Acoustic Sound Insulation Performance based on Knauf studs at 600mm centres and non-deflection arrangement. Systems that are fire resistance and / or offering acoustic sound performance must have all outer joints taped and filled in accordance with Knauf recommendations. Systems are tested as imperforate.

Knauf Performer - Fire Panel (BS Compliance)



Got a question? Email our Technical Service on technical-uk@knauf.com or call 0800 521050 (option 2)

92mm Stud Solutions

Knauf Stud depth and gauge (mm)	Knauf Plasterboard layers to each side of Knauf Stud (no)	Thickness of Knauf Plasterboard (mm)	Knauf Plasterboard	Knauf Insulation Acoustic Roll - Cavity Insulation (mm)	System width (mm) excluding finishes	System code & Maximum height ¹ (mm) @ 600mm centres	System code & Maximum height ¹ (mm) @ 400mm centres	System code & Maximum height ¹ (mm) @ 300mm centres	Fire resistance period ² (minutes)	Acoustic Sound Insulation ³ (dB Rw)	Deflection allowance (mm)	Deflection head arrangement			
92 'C' Stud (0.70)	1	12.5	Fire Panel	Non Insulated	119	BS-PC-92-070-6-1-12.5-FP-0	4900	BS-PC-92-070-4-1-12.5-FP-0	5300	BS-PC-92-070-3-1-12.5-FP-0	5600	30	35	-25	Figure 1
	1	12.5	Fire Panel	Non Insulated	119	BS-PC-92-070-6-1-12.5-FP-0	4900	BS-PC-92-070-4-1-12.5-FP-0	5300	BS-PC-92-070-3-1-12.5-FP-0	5600	30	35	-50	Figure 5
	1	12.5	Fire Panel	25	119	BS-PC-92-070-6-1-12.5-FP-25	4900	BS-PC-92-070-4-1-12.5-FP-25	5300	BS-PC-92-070-3-1-12.5-FP-25	5600	30	42	-25	Figure 3
	1	12.5	Fire Panel	25	119	BS-PC-92-070-6-1-12.5-FP-25	4900	BS-PC-92-070-4-1-12.5-FP-25	5300	BS-PC-92-070-3-1-12.5-FP-25	5600	30	42	-50	Figure 7
	1	15	Fire Panel	Non Insulated	124	BS-PC-92-070-6-1-15-FP-0	5100	BS-PC-92-070-4-1-15-FP-0	5400	BS-PC-92-070-3-1-15-FP-0	5800	60	37	-25	Figure 9
	1	15	Fire Panel	Non Insulated	124	BS-PC-92-070-6-1-15-FP-0	5100	BS-PC-92-070-4-1-15-FP-0	5400	BS-PC-92-070-3-1-15-FP-0	5800	60	37	-50	Figure 10
	1	15	Fire Panel	25	124	BS-PC-92-070-6-1-15-FP-25	5100	BS-PC-92-070-4-1-15-FP-25	5400	BS-PC-92-070-3-1-15-FP-25	5800	Not Tested	43	-25	Figure 3
	1	15	Fire Panel	25	124	BS-PC-92-070-6-1-15-FP-25	5100	BS-PC-92-070-4-1-15-FP-25	5400	BS-PC-92-070-3-1-15-FP-25	5800	Not Tested	43	-50	Figure 7
	2	12.5	Fire Panel	Non Insulated	144	BS-PC-92-070-6-2-12.5-FP-0	5700	BS-PC-92-070-4-2-12.5-FP-0	6100	BS-PC-92-070-3-2-12.5-FP-0	6300	120	43	-25	Figure 13
	2	12.5	Fire Panel	Non Insulated	144	BS-PC-92-070-6-2-12.5-FP-0	5700	BS-PC-92-070-4-2-12.5-FP-0	6100	BS-PC-92-070-3-2-12.5-FP-0	6300	120	43	-50	Figure 15
	2	12.5	Fire Panel	25	144	BS-PC-92-070-6-2-12.5-FP-25	5700	BS-PC-92-070-4-2-12.5-FP-25	6100	BS-PC-92-070-3-2-12.5-FP-25	6300	120	52	-25	Figure 14
	2	12.5	Fire Panel	25	144	BS-PC-92-070-6-2-12.5-FP-25	5700	BS-PC-92-070-4-2-12.5-FP-25	6100	BS-PC-92-070-3-2-12.5-FP-25	6300	120	52	-50	Figure 16
	2	15	Fire Panel	Non Insulated	154	BS-PC-92-070-6-2-15-FP-0	6000	BS-PC-92-070-4-2-15-FP-0	6300	BS-PC-92-070-3-2-15-FP-0	6600	120	46	-25	Figure 13
	2	15	Fire Panel	Non Insulated	154	BS-PC-92-070-6-2-15-FP-0	6000	BS-PC-92-070-4-2-15-FP-0	6300	BS-PC-92-070-3-2-15-FP-0	6600	120	46	-50	Figure 15
	2	15	Fire Panel	25	154	BS-PC-92-070-6-2-15-FP-25	6000	BS-PC-92-070-4-2-15-FP-25	6300	BS-PC-92-070-3-2-15-FP-25	6600	Not Tested	54	-25	Figure 14
	2	15	Fire Panel	25	154	BS-PC-92-070-6-2-15-FP-25	6000	BS-PC-92-070-4-2-15-FP-25	6300	BS-PC-92-070-3-2-15-FP-25	6600	Not Tested	54	-50	Figure 16

146mm Stud Solutions

Knauf Stud depth and gauge (mm)	Knauf Plasterboard layers to each side of Knauf Stud (no)	Thickness of Knauf Plasterboard (mm)	Knauf Plasterboard	Knauf Insulation Acoustic Roll - Cavity Insulation (mm)	System width (mm) excluding finishes	System code & Maximum height ¹ (mm) @ 600mm centres	System code & Maximum height ¹ (mm) @ 400mm centres	System code & Maximum height ¹ (mm) @ 300mm centres	Fire resistance period ² (minutes)	Acoustic Sound Insulation ³ (dB Rw)	Deflection allowance (mm)	Deflection head arrangement			
146 'C' Stud (0.55)	1	12.5	Fire Panel	Non Insulated	173	BS-PC-146-055-6-1-12.5-FP-0	5600	BS-PC-146-055-4-1-12.5-FP-0	6400	BS-PC-146-055-3-1-12.5-FP-0	7000	30	35	-25	Figure 1
	1	12.5	Fire Panel	Non Insulated	173	BS-PC-146-055-6-1-12.5-FP-0	5600	BS-PC-146-055-4-1-12.5-FP-0	6400	BS-PC-146-055-3-1-12.5-FP-0	7000	30	35	-50	Figure 5
	1	12.5	Fire Panel	25	173	BS-PC-146-055-6-1-12.5-FP-25	5600	BS-PC-146-055-4-1-12.5-FP-25	6400	BS-PC-146-055-3-1-12.5-FP-25	7000	30	42	-25	Figure 3
	1	12.5	Fire Panel	25	173	BS-PC-146-055-6-1-12.5-FP-25	5600	BS-PC-146-055-4-1-12.5-FP-25	6400	BS-PC-146-055-3-1-12.5-FP-25	7000	30	42	-50	Figure 7
	1	15	Fire Panel	Non Insulated	178	BS-PC-146-055-6-1-15-FP-0	5800	BS-PC-146-055-4-1-15-FP-0	6700	BS-PC-146-055-3-1-15-FP-0	7200	60	37	-25	Figure 9
	1	15	Fire Panel	Non Insulated	178	BS-PC-146-055-6-1-15-FP-0	5800	BS-PC-146-055-4-1-15-FP-0	6700	BS-PC-146-055-3-1-15-FP-0	7200	60	37	-50	Figure 10
	1	15	Fire Panel	25	178	BS-PC-146-055-6-1-15-FP-25	5800	BS-PC-146-055-4-1-15-FP-25	6700	BS-PC-146-055-3-1-15-FP-25	7200	Not Tested	43	-25	Figure 3
	1	15	Fire Panel	25	178	BS-PC-146-055-6-1-15-FP-25	5800	BS-PC-146-055-4-1-15-FP-25	6700	BS-PC-146-055-3-1-15-FP-25	7200	Not Tested	43	-50	Figure 7
	2	12.5	Fire Panel	Non Insulated	198	BS-PC-146-055-6-2-12.5-FP-0	6300	BS-PC-146-055-4-2-12.5-FP-0	7500	BS-PC-146-055-3-2-12.5-FP-0	7900	120	49	-25	Figure 13
	2	12.5	Fire Panel	Non Insulated	198	BS-PC-146-055-6-2-12.5-FP-0	6300	BS-PC-146-055-4-2-12.5-FP-0	7500	BS-PC-146-055-3-2-12.5-FP-0	7900	120	49	-50	Figure 15
	2	12.5	Fire Panel	25	198	BS-PC-146-055-6-2-12.5-FP-25	6300	BS-PC-146-055-4-2-12.5-FP-25	7500	BS-PC-146-055-3-2-12.5-FP-25	7900	120	53	-25	Figure 14
	2	12.5	Fire Panel	25	198	BS-PC-146-055-6-2-12.5-FP-25	6300	BS-PC-146-055-4-2-12.5-FP-25	7500	BS-PC-146-055-3-2-12.5-FP-25	7900	120	53	-50	Figure 16
	2	15	Fire Panel	Non Insulated	208	BS-PC-146-055-6-2-15-FP-0	6600	BS-PC-146-055-4-2-15-FP-0	7900	BS-PC-146-055-3-2-15-FP-0	8300	120	50	-25	Figure 13
	2	15	Fire Panel	Non Insulated	208	BS-PC-146-055-6-2-15-FP-0	6600	BS-PC-146-055-4-2-15-FP-0	7900	BS-PC-146-055-3-2-15-FP-0	8300	120	50	-50	Figure 15
	2	15	Fire Panel	25	208	BS-PC-146-055-6-2-15-FP-25	6600	BS-PC-146-055-4-2-15-FP-25	7900	BS-PC-146-055-3-2-15-FP-25	8300	Not Tested	54	-25	Figure 14
	2	15	Fire Panel	25	208	BS-PC-146-055-6-2-15-FP-25	6600	BS-PC-146-055-4-2-15-FP-25	7900	BS-PC-146-055-3-2-15-FP-25	8300	Not Tested	54	-50	Figure 16

1. Maximum height for BS Compliance Systems: The stated maximum height figure is based on the maximum cold state height, calculated to limiting deflection of L/240 @ 200 Pascals.
2. Fire resistance period: Tested in accordance with BS EN 1364-1. Fire resistance period is inclusive of fire integrity and fire insulation (EI). Fire resistance performance must be reviewed against Knauf specifications and standard details.
3. Acoustic sound insulation: Tested or assessed in accordance with BS EN ISO 10140-1 and BS EN 10140-2. Important - Acoustic Sound Insulation Performance based on Knauf studs at 600mm centres and non-deflection arrangement. Systems that are fire resistance and / or offering acoustic sound performance must have all outer joints taped and filled in accordance with Knauf recommendations. Systems are tested as imperforate.

BS Compliance Specifications

Knauf Performer - Soundshield Plus (BS Compliance)



Got a question? Email our Technical Service on technical-uk@knauf.com or call 0800 521050 (option 2)

50mm Stud Solutions

Knauf Stud depth and gauge (mm)	Knauf Plasterboard layers to each side of Knauf Stud (no)	Thickness of Knauf Plasterboard (mm)	Knauf Plasterboard	Knauf Insulation Acoustic Roll - Cavity Insulation (mm)	System width (mm) excluding finishes	System code & Maximum height ¹ (mm) @ 600mm centres	System code & Maximum height ¹ (mm) @ 400mm centres	System code & Maximum height ¹ (mm) @ 300mm centres	Fire resistance period ² (minutes)	Acoustic Sound Insulation ³ (dB Rw)	Deflection allowance (mm)	Deflection head arrangement			
50'C Stud (0.55)	1	12.5	Soundshield Plus	Non Insulated	77	BS-PC-50-055-6-1-12.5-SSP-0	3000	BS-PC-50-055-4-1-12.5-SSP-0	3200	BS-PC-50-055-3-1-12.5-SSP-0	3400	30	38	-25	Figure 1
	1	12.5	Soundshield Plus	25	77	BS-PC-50-055-6-1-12.5-SSP-25	3000	BS-PC-50-055-4-1-12.5-SSP-25	3200	BS-PC-50-055-3-1-12.5-SSP-25	3400	30	44	-25	Figure 3
	1	15	Soundshield Plus	Non Insulated	82	BS-PC-50-055-6-1-15-SSP-0	3100	BS-PC-50-055-4-1-15-SSP-0	3300	BS-PC-50-055-3-1-15-SSP-0	3500	30	37	-25	Figure 1
	1	15	Soundshield Plus	25	82	BS-PC-50-055-6-1-15-SSP-25	3100	BS-PC-50-055-4-1-15-SSP-25	3300	BS-PC-50-055-3-1-15-SSP-25	3500	60	42	-25	Figure 11
	2	12.5	Soundshield Plus	Non Insulated	102	BS-PC-50-055-6-2-12.5-SSP-0	3700	BS-PC-50-055-4-2-12.5-SSP-0	3800	BS-PC-50-055-3-2-12.5-SSP-0	4000	60	46	-25	Figure 2
	2	12.5	Soundshield Plus	25	102	BS-PC-50-055-6-2-12.5-SSP-25	3700	BS-PC-50-055-4-2-12.5-SSP-25	3800	BS-PC-50-055-3-2-12.5-SSP-25	4000	60	53	-25	Figure 4
	2	15	Soundshield Plus	Non Insulated	112	BS-PC-50-055-6-2-15-SSP-0	3900	BS-PC-50-055-4-2-15-SSP-0	4000	BS-PC-50-055-3-2-15-SSP-0	4200	120	45	-25	Figure 13
	2	15	Soundshield Plus	25	112	BS-PC-50-055-6-2-15-SSP-25	3900	BS-PC-50-055-4-2-15-SSP-25	4000	BS-PC-50-055-3-2-15-SSP-25	4200	120	52	-25	Figure 14

70mm Stud Solutions

Knauf Stud depth and gauge (mm)	Knauf Plasterboard layers to each side of Knauf Stud (no)	Thickness of Knauf Plasterboard (mm)	Knauf Plasterboard	Knauf Insulation Acoustic Roll - Cavity Insulation (mm)	System width (mm) excluding finishes	System code & Maximum height ¹ (mm) @ 600mm centres	System code & Maximum height ¹ (mm) @ 400mm centres	System code & Maximum height ¹ (mm) @ 300mm centres	Fire resistance period ² (minutes)	Acoustic Sound Insulation ³ (dB Rw)	Deflection allowance (mm)	Deflection head arrangement			
70'C Stud (0.55)	1	12.5	Soundshield Plus	Non Insulated	97	BS-PC-70-055-6-1-12.5-SSP-0	3600	BS-PC-70-055-4-1-12.5-SSP-0	3900	BS-PC-70-055-3-1-12.5-SSP-0	4200	30	38	-25	Figure 1
	1	12.5	Soundshield Plus	Non Insulated	97	BS-PC-70-055-6-1-12.5-SSP-0	3600	BS-PC-70-055-4-1-12.5-SSP-0	3900	BS-PC-70-055-3-1-12.5-SSP-0	4200	30	38	-50	Figure 5
	1	12.5	Soundshield Plus	25	97	BS-PC-70-055-6-1-12.5-SSP-25	3600	BS-PC-70-055-4-1-12.5-SSP-25	3900	BS-PC-70-055-3-1-12.5-SSP-25	4200	30	45	-25	Figure 3
	1	12.5	Soundshield Plus	25	97	BS-PC-70-055-6-1-12.5-SSP-25	3600	BS-PC-70-055-4-1-12.5-SSP-25	3900	BS-PC-70-055-3-1-12.5-SSP-25	4200	30	45	-50	Figure 7
	1	15	Soundshield Plus	Non Insulated	102	BS-PC-70-055-6-1-15-SSP-0	4000	BS-PC-70-055-4-1-15-SSP-0	4300	BS-PC-70-055-3-1-15-SSP-0	4500	30	40	-25	Figure 1
	1	15	Soundshield Plus	Non Insulated	102	BS-PC-70-055-6-1-15-SSP-0	4000	BS-PC-70-055-4-1-15-SSP-0	4300	BS-PC-70-055-3-1-15-SSP-0	4500	30	40	-50	Figure 5
	1	15	Soundshield Plus	25	102	BS-PC-70-055-6-1-15-SSP-25	4000	BS-PC-70-055-4-1-15-SSP-25	4300	BS-PC-70-055-3-1-15-SSP-25	4500	60	47	-25	Figure 11
	1	15	Soundshield Plus	25	102	BS-PC-70-055-6-1-15-SSP-25	4000	BS-PC-70-055-4-1-15-SSP-25	4300	BS-PC-70-055-3-1-15-SSP-25	4500	60	47	-50	Figure 12
	2	12.5	Soundshield Plus	Non Insulated	122	BS-PC-70-055-6-2-12.5-SSP-0	4500	BS-PC-70-055-4-2-12.5-SSP-0	4700	BS-PC-70-055-3-2-12.5-SSP-0	4900	60	48	-25	Figure 2
	2	12.5	Soundshield Plus	Non Insulated	122	BS-PC-70-055-6-2-12.5-SSP-0	4500	BS-PC-70-055-4-2-12.5-SSP-0	4700	BS-PC-70-055-3-2-12.5-SSP-0	4900	60	48	-50	Figure 6
	2	12.5	Soundshield Plus	25	122	BS-PC-70-055-6-2-12.5-SSP-25	4500	BS-PC-70-055-4-2-12.5-SSP-25	4700	BS-PC-70-055-3-2-12.5-SSP-25	4900	60	53	-25	Figure 4
	2	12.5	Soundshield Plus	25	122	BS-PC-70-055-6-2-12.5-SSP-25	4500	BS-PC-70-055-4-2-12.5-SSP-25	4700	BS-PC-70-055-3-2-12.5-SSP-25	4900	60	53	-50	Figure 8
	2	15	Soundshield Plus	Non Insulated	132	BS-PC-70-055-6-2-15-SSP-0	4800	BS-PC-70-055-4-2-15-SSP-0	5000	BS-PC-70-055-3-2-15-SSP-0	5200	120	49	-25	Figure 13
	2	15	Soundshield Plus	Non Insulated	132	BS-PC-70-055-6-2-15-SSP-0	4800	BS-PC-70-055-4-2-15-SSP-0	5000	BS-PC-70-055-3-2-15-SSP-0	5200	120	49	-50	Figure 15
	2	15	Soundshield Plus	25	132	BS-PC-70-055-6-2-15-SSP-25	4800	BS-PC-70-055-4-2-15-SSP-25	5000	BS-PC-70-055-3-2-15-SSP-25	5200	120	55	-25	Figure 14
	2	15	Soundshield Plus	25	132	BS-PC-70-055-6-2-15-SSP-25	4800	BS-PC-70-055-4-2-15-SSP-25	5000	BS-PC-70-055-3-2-15-SSP-25	5200	120	55	-50	Figure 16

1. **Maximum height for BS Compliance Systems:** The stated maximum height figure is based on the maximum cold state height, calculated to limiting deflection of L/240 @ 200 Pascals.
 2. **Fire resistance period:** Tested in accordance with BS EN 1364-1. Fire resistance period is inclusive of fire integrity and fire insulation (EI). Fire resistance performance must be reviewed against Knauf specifications and standard details.
 3. **Acoustic sound insulation:** Tested or assessed in accordance with BS EN ISO 10140-1 and BS EN 10140-2. Important - Acoustic Sound Insulation Performance based on Knauf studs at 600mm centres and non-deflection arrangement. Systems that are fire resistance and / or offering acoustic sound performance must have all outer joints taped and filled in accordance with Knauf recommendations. Systems are tested as imperforate.

Knauf Performer - Soundshield Plus (BS Compliance)



Got a question? Email our Technical Service on technical-uk@knauf.com or call 0800 521050 (option 2)

92mm Stud Solutions

Knauf Stud depth and gauge (mm)	Knauf Plasterboard layers to each side of Knauf Stud (no)	Thickness of Knauf Plasterboard (mm)	Knauf Plasterboard	Knauf Insulation Acoustic Roll - Cavity Insulation (mm)	System width (mm) excluding finishes	System code & Maximum height ¹ (mm) @ 600mm centres	System code & Maximum height ¹ (mm) @ 400mm centres	System code & Maximum height ¹ (mm) @ 300mm centres	Fire resistance period ² (minutes)	Acoustic Sound Insulation ³ (dB Rw)	Deflection allowance (mm)	Deflection head arrangement			
92'C Stud (0.70)	1	12.5	Soundshield Plus	Non Insulated	119	BS-PC-92-070-6-1-12.5-SSP-0	4900	BS-PC-92-070-4-1-12.5-SSP-0	5300	BS-PC-92-070-3-1-12.5-SSP-0	5600	30	38	-25	Figure 1
	1	12.5	Soundshield Plus	Non Insulated	119	BS-PC-92-070-6-1-12.5-SSP-0	4900	BS-PC-92-070-4-1-12.5-SSP-0	5300	BS-PC-92-070-3-1-12.5-SSP-0	5600	30	38	-50	Figure 5
	1	12.5	Soundshield Plus	25	119	BS-PC-92-070-6-1-12.5-SSP-25	4900	BS-PC-92-070-4-1-12.5-SSP-25	5300	BS-PC-92-070-3-1-12.5-SSP-25	5600	30	45	-25	Figure 3
	1	12.5	Soundshield Plus	25	119	BS-PC-92-070-6-1-12.5-SSP-25	4900	BS-PC-92-070-4-1-12.5-SSP-25	5300	BS-PC-92-070-3-1-12.5-SSP-25	5600	30	45	-50	Figure 7
	1	15	Soundshield Plus	Non Insulated	124	BS-PC-92-070-6-1-15-SSP-0	5100	BS-PC-92-070-4-1-15-SSP-0	5400	BS-PC-92-070-3-1-15-SSP-0	5800	30	40	-25	Figure 1
	1	15	Soundshield Plus	Non Insulated	124	BS-PC-92-070-6-1-15-SSP-0	5100	BS-PC-92-070-4-1-15-SSP-0	5400	BS-PC-92-070-3-1-15-SSP-0	5800	30	40	-50	Figure 5
	1	15	Soundshield Plus	25	124	BS-PC-92-070-6-1-15-SSP-25	5100	BS-PC-92-070-4-1-15-SSP-25	5400	BS-PC-92-070-3-1-15-SSP-25	5800	60	47	-25	Figure 11
	1	15	Soundshield Plus	25	124	BS-PC-92-070-6-1-15-SSP-25	5100	BS-PC-92-070-4-1-15-SSP-25	5400	BS-PC-92-070-3-1-15-SSP-25	5800	60	47	-50	Figure 12
	2	12.5	Soundshield Plus	Non Insulated	144	BS-PC-92-070-6-2-12.5-SSP-0	5700	BS-PC-92-070-4-2-12.5-SSP-0	6100	BS-PC-92-070-3-2-12.5-SSP-0	6300	60	48	-25	Figure 2
	2	12.5	Soundshield Plus	Non Insulated	144	BS-PC-92-070-6-2-12.5-SSP-0	5700	BS-PC-92-070-4-2-12.5-SSP-0	6100	BS-PC-92-070-3-2-12.5-SSP-0	6300	60	48	-50	Figure 6
	2	12.5	Soundshield Plus	25	144	BS-PC-92-070-6-2-12.5-SSP-25	5700	BS-PC-92-070-4-2-12.5-SSP-25	6100	BS-PC-92-070-3-2-12.5-SSP-25	6300	60	53	-25	Figure 4
	2	12.5	Soundshield Plus	25	144	BS-PC-92-070-6-2-12.5-SSP-25	5700	BS-PC-92-070-4-2-12.5-SSP-25	6100	BS-PC-92-070-3-2-12.5-SSP-25	6300	60	53	-50	Figure 8
	2	15	Soundshield Plus	Non Insulated	154	BS-PC-92-070-6-2-15-SSP-0	6000	BS-PC-92-070-4-2-15-SSP-0	6300	BS-PC-92-070-3-2-15-SSP-0	6600	120	49	-25	Figure 13
	2	15	Soundshield Plus	Non Insulated	154	BS-PC-92-070-6-2-15-SSP-0	6000	BS-PC-92-070-4-2-15-SSP-0	6300	BS-PC-92-070-3-2-15-SSP-0	6600	120	49	-50	Figure 15
	2	15	Soundshield Plus	25	154	BS-PC-92-070-6-2-15-SSP-25	6000	BS-PC-92-070-4-2-15-SSP-25	6300	BS-PC-92-070-3-2-15-SSP-25	6600	120	55	-25	Figure 14
	2	15	Soundshield Plus	25	154	BS-PC-92-070-6-2-15-SSP-25	6000	BS-PC-92-070-4-2-15-SSP-25	6300	BS-PC-92-070-3-2-15-SSP-25	6600	120	55	-50	Figure 16

146mm Stud Solutions

Knauf Stud depth and gauge (mm)	Knauf Plasterboard layers to each side of Knauf Stud (no)	Thickness of Knauf Plasterboard (mm)	Knauf Plasterboard	Knauf Insulation Acoustic Roll - Cavity Insulation (mm)	System width (mm) excluding finishes	System code & Maximum height ¹ (mm) @ 600mm centres	System code & Maximum height ¹ (mm) @ 400mm centres	System code & Maximum height ¹ (mm) @ 300mm centres	Fire resistance period ² (minutes)	Acoustic Sound Insulation ³ (dB Rw)	Deflection allowance (mm)	Deflection head arrangement			
146'C Stud (0.55)	1	12.5	Soundshield Plus	Non Insulated	173	BS-PC-146-055-6-1-12.5-SSP-0	5600	BS-PC-146-055-4-1-12.5-SSP-0	6400	BS-PC-146-055-3-1-12.5-SSP-0	7000	30	38	-25	Figure 1
	1	12.5	Soundshield Plus	Non Insulated	173	BS-PC-146-055-6-1-12.5-SSP-0	5600	BS-PC-146-055-4-1-12.5-SSP-0	6400	BS-PC-146-055-3-1-12.5-SSP-0	7000	30	38	-50	Figure 5
	1	12.5	Soundshield Plus	25	173	BS-PC-146-055-6-1-12.5-SSP-25	5600	BS-PC-146-055-4-1-12.5-SSP-25	6400	BS-PC-146-055-3-1-12.5-SSP-25	7000	30	45	-25	Figure 3
	1	12.5	Soundshield Plus	25	173	BS-PC-146-055-6-1-12.5-SSP-25	5600	BS-PC-146-055-4-1-12.5-SSP-25	6400	BS-PC-146-055-3-1-12.5-SSP-25	7000	30	45	-50	Figure 7
	1	15	Soundshield Plus	Non Insulated	178	BS-PC-146-055-6-1-15-SSP-0	5800	BS-PC-146-055-4-1-15-SSP-0	6700	BS-PC-146-055-3-1-15-SSP-0	7200	30	44	-25	Figure 1
	1	15	Soundshield Plus	Non Insulated	178	BS-PC-146-055-6-1-15-SSP-0	5800	BS-PC-146-055-4-1-15-SSP-0	6700	BS-PC-146-055-3-1-15-SSP-0	7200	30	44	-50	Figure 5
	1	15	Soundshield Plus	25	178	BS-PC-146-055-6-1-15-SSP-25	5800	BS-PC-146-055-4-1-15-SSP-25	6700	BS-PC-146-055-3-1-15-SSP-25	7200	60	47	-25	Figure 11
	1	15	Soundshield Plus	25	178	BS-PC-146-055-6-1-15-SSP-25	5800	BS-PC-146-055-4-1-15-SSP-25	6700	BS-PC-146-055-3-1-15-SSP-25	7200	60	47	-50	Figure 12
	2	12.5	Soundshield Plus	Non Insulated	198	BS-PC-146-055-6-2-12.5-SSP-0	6300	BS-PC-146-055-4-2-12.5-SSP-0	7500	BS-PC-146-055-3-2-12.5-SSP-0	7900	60	49	-25	Figure 2
	2	12.5	Soundshield Plus	Non Insulated	198	BS-PC-146-055-6-2-12.5-SSP-0	6300	BS-PC-146-055-4-2-12.5-SSP-0	7500	BS-PC-146-055-3-2-12.5-SSP-0	7900	60	49	-50	Figure 6
	2	12.5	Soundshield Plus	25	198	BS-PC-146-055-6-2-12.5-SSP-25	6300	BS-PC-146-055-4-2-12.5-SSP-25	7500	BS-PC-146-055-3-2-12.5-SSP-25	7900	60	53	-25	Figure 4
	2	12.5	Soundshield Plus	25	198	BS-PC-146-055-6-2-12.5-SSP-25	6300	BS-PC-146-055-4-2-12.5-SSP-25	7500	BS-PC-146-055-3-2-12.5-SSP-25	7900	60	53	-50	Figure 8
	2	15	Soundshield Plus	Non Insulated	208	BS-PC-146-055-6-2-15-SSP-0	6600	BS-PC-146-055-4-2-15-SSP-0	7900	BS-PC-146-055-3-2-15-SSP-0	8300	120	52	-25	Figure 13
	2	15	Soundshield Plus	Non Insulated	208	BS-PC-146-055-6-2-15-SSP-0	6600	BS-PC-146-055-4-2-15-SSP-0	7900	BS-PC-146-055-3-2-15-SSP-0	8300	120	52	-50	Figure 15
	2	15	Soundshield Plus	25	208	BS-PC-146-055-6-2-15-SSP-25	6600	BS-PC-146-055-4-2-15-SSP-25	7900	BS-PC-146-055-3-2-15-SSP-25	8300	120	55	-25	Figure 14
	2	15	Soundshield Plus	25	208	BS-PC-146-055-6-2-15-SSP-25	6600	BS-PC-146-055-4-2-15-SSP-25	7900	BS-PC-146-055-3-2-15-SSP-25	8300	120	55	-50	Figure 16

1. **Maximum height for BS Compliance Systems:** The stated maximum height figure is based on the maximum cold state height, calculated to limiting deflection of L/240 @ 200 Pascals.
 2. **Fire resistance period:** Tested in accordance with BS EN 1364-1. Fire resistance period is inclusive of fire integrity and fire insulation (EI). Fire resistance performance must be reviewed against Knauf specifications and standard details.
 3. **Acoustic sound insulation:** Tested or assessed in accordance with BS EN ISO 10140-1 and BS EN 10140-2. Important - Acoustic Sound Insulation Performance based on Knauf studs at 600mm centres and non-deflection arrangement. Systems that are fire resistance and / or offering acoustic sound performance must have all outer joints taped and filled in accordance with Knauf recommendations. Systems are tested as imperforate.

Knauf Performer - Performance Plus (BS Compliance)



Got a question? Email our Technical Service on technical-uk@knauf.com or call 0800 521050 (option 2)

50mm Stud Solutions

Knauf Stud depth and gauge (mm)	Knauf Plasterboard layers to each side of Knauf Stud (no)	Thickness of Knauf Plasterboard (mm)	Knauf Plasterboard	Knauf Insulation Acoustic Roll - Cavity Insulation (mm)	System width (mm) excluding finishes	System code & Maximum height ¹ (mm) @ 600mm centres	System code & Maximum height ¹ (mm) @ 400mm centres	System code & Maximum height ¹ (mm) @ 300mm centres	Fire resistance period ² (minutes)	Acoustic Sound Insulation ³ (dB Rw)	Deflection allowance (mm)	Deflection head arrangement			
50'C Stud (0.55)	1	12.5	Performance Plus	Non Insulated	77	BS-PC-50-055-6-1-12.5-PP-0	3000	BS-PC-50-055-4-1-12.5-PP-0	3200	BS-PC-50-055-3-1-12.5-PP-0	3400	30	38	-25	Figure 1
	1	12.5	Performance Plus	25	77	BS-PC-50-055-6-1-12.5-PP-25	3000	BS-PC-50-055-4-1-12.5-PP-25	3200	BS-PC-50-055-3-1-12.5-PP-25	3400	30	44	-25	Figure 3
	1	15	Performance Plus	Non Insulated	82	BS-PC-50-055-6-1-15-PP-0	3100	BS-PC-50-055-4-1-15-PP-0	3300	BS-PC-50-055-3-1-15-PP-0	3500	30	37	-25	Figure 1
	1	15	Performance Plus	25	82	BS-PC-50-055-6-1-15-PP-25	3100	BS-PC-50-055-4-1-15-PP-25	3300	BS-PC-50-055-3-1-15-PP-25	3500	Not Tested	42	-25	Figure 3
	2	12.5	Performance Plus	Non Insulated	102	BS-PC-50-055-6-2-12.5-PP-0	3700	BS-PC-50-055-4-2-12.5-PP-0	3800	BS-PC-50-055-3-2-12.5-PP-0	4000	120	46	-25	Figure 13
	2	12.5	Performance Plus	25	102	BS-PC-50-055-6-2-12.5-PP-25	3700	BS-PC-50-055-4-2-12.5-PP-25	3800	BS-PC-50-055-3-2-12.5-PP-25	4000	Not Tested	53	-25	Figure 14
	2	15	Performance Plus	Non Insulated	112	BS-PC-50-055-6-2-15-PP-0	3900	BS-PC-50-055-4-2-15-PP-0	4000	BS-PC-50-055-3-2-15-PP-0	4200	120	45	-25	Figure 13
	2	15	Performance Plus	25	112	BS-PC-50-055-6-2-15-PP-25	3900	BS-PC-50-055-4-2-15-PP-25	4000	BS-PC-50-055-3-2-15-PP-25	4200	Not Tested	52	-25	Figure 14

70mm Stud Solutions

Knauf Stud depth and gauge (mm)	Knauf Plasterboard layers to each side of Knauf Stud (no)	Thickness of Knauf Plasterboard (mm)	Knauf Plasterboard	Knauf Insulation Acoustic Roll - Cavity Insulation (mm)	System width (mm) excluding finishes	System code & Maximum height ¹ (mm) @ 600mm centres	System code & Maximum height ¹ (mm) @ 400mm centres	System code & Maximum height ¹ (mm) @ 300mm centres	Fire resistance period ² (minutes)	Acoustic Sound Insulation ³ (dB Rw)	Deflection allowance (mm)	Deflection head arrangement			
70'C Stud (0.55)	1	12.5	Performance Plus	Non Insulated	97	BS-PC-70-055-6-1-12.5-PP-0	3600	BS-PC-70-055-4-1-12.5-PP-0	3900	BS-PC-70-055-3-1-12.5-PP-0	4200	30	38	-25	Figure 1
	1	12.5	Performance Plus	Non Insulated	97	BS-PC-70-055-6-1-12.5-PP-0	3600	BS-PC-70-055-4-1-12.5-PP-0	3900	BS-PC-70-055-3-1-12.5-PP-0	4200	30	38	-50	Figure 5
	1	12.5	Performance Plus	25	97	BS-PC-70-055-6-1-12.5-PP-25	3600	BS-PC-70-055-4-1-12.5-PP-25	3900	BS-PC-70-055-3-1-12.5-PP-25	4200	30	45	-25	Figure 3
	1	12.5	Performance Plus	25	97	BS-PC-70-055-6-1-12.5-PP-25	3600	BS-PC-70-055-4-1-12.5-PP-25	3900	BS-PC-70-055-3-1-12.5-PP-25	4200	30	45	-50	Figure 7
	1	15	Performance Plus	Non Insulated	102	BS-PC-70-055-6-1-15-PP-0	4000	BS-PC-70-055-4-1-15-PP-0	4300	BS-PC-70-055-3-1-15-PP-0	4500	60	40	-25	Figure 9
	1	15	Performance Plus	Non Insulated	102	BS-PC-70-055-6-1-15-PP-0	4000	BS-PC-70-055-4-1-15-PP-0	4300	BS-PC-70-055-3-1-15-PP-0	4500	60	40	-50	Figure 10
	1	15	Performance Plus	25	102	BS-PC-70-055-6-1-15-PP-25	4000	BS-PC-70-055-4-1-15-PP-25	4300	BS-PC-70-055-3-1-15-PP-25	4500	60	45	-25	Figure 11
	1	15	Performance Plus	25	102	BS-PC-70-055-6-1-15-PP-25	4000	BS-PC-70-055-4-1-15-PP-25	4300	BS-PC-70-055-3-1-15-PP-25	4500	60	45	-50	Figure 12
	2	12.5	Performance Plus	Non Insulated	122	BS-PC-70-055-6-2-12.5-PP-0	4500	BS-PC-70-055-4-2-12.5-PP-0	4700	BS-PC-70-055-3-2-12.5-PP-0	4900	120	48	-25	Figure 13
	2	12.5	Performance Plus	Non Insulated	122	BS-PC-70-055-6-2-12.5-PP-0	4500	BS-PC-70-055-4-2-12.5-PP-0	4700	BS-PC-70-055-3-2-12.5-PP-0	4900	120	48	-50	Figure 15
	2	12.5	Performance Plus	25	122	BS-PC-70-055-6-2-12.5-PP-25	4500	BS-PC-70-055-4-2-12.5-PP-25	4700	BS-PC-70-055-3-2-12.5-PP-25	4900	120	53	-25	Figure 14
	2	12.5	Performance Plus	25	122	BS-PC-70-055-6-2-12.5-PP-25	4500	BS-PC-70-055-4-2-12.5-PP-25	4700	BS-PC-70-055-3-2-12.5-PP-25	4900	120	53	-50	Figure 16
	2	15	Performance Plus	Non Insulated	132	BS-PC-70-055-6-2-15-PP-0	4800	BS-PC-70-055-4-2-15-PP-0	5000	BS-PC-70-055-3-2-15-PP-0	5200	120	48	-25	Figure 13
	2	15	Performance Plus	Non Insulated	132	BS-PC-70-055-6-2-15-PP-0	4800	BS-PC-70-055-4-2-15-PP-0	5000	BS-PC-70-055-3-2-15-PP-0	5200	120	48	-50	Figure 15
	2	15	Performance Plus	25	132	BS-PC-70-055-6-2-15-PP-25	4800	BS-PC-70-055-4-2-15-PP-25	5000	BS-PC-70-055-3-2-15-PP-25	5200	60*	54	-25	Figure 14
	2	15	Performance Plus	25	132	BS-PC-70-055-6-2-15-PP-25	4800	BS-PC-70-055-4-2-15-PP-25	5000	BS-PC-70-055-3-2-15-PP-25	5200	60*	54	-50	Figure 16

*System performance based on single layer system

1. **Maximum height for BS Compliance Systems:** The stated maximum height figure is based on the maximum cold state height, calculated to limiting deflection of L/240 @ 200 Pascals.
 2. **Fire resistance period:** Tested in accordance with BS EN 1364-1. Fire resistance period is inclusive of fire integrity and fire insulation (EI). Fire resistance performance must be reviewed against Knauf specifications and standard details.
 3. **Acoustic sound insulation:** Tested or assessed in accordance with BS EN ISO 10140-1 and BS EN 10140-2. Important - Acoustic Sound Insulation Performance based on Knauf studs at 600mm centres and non-deflection arrangement. Systems that are fire resistance and / or offering acoustic sound performance must have all outer joints taped and filled in accordance with Knauf recommendations. Systems are tested as imperforate.

BS Compliance Specifications

Knauf Performer - Performance Plus (BS Compliance)



Got a question? Email our Technical Service on technical-uk@knauf.com or call 0800 521050 (option 2)

92mm Stud Solutions

Knauf Stud depth and gauge (mm)	Knauf Plasterboard layers to each side of Knauf Stud (no)	Thickness of Knauf Plasterboard (mm)	Knauf Plasterboard	Knauf Insulation Acoustic Roll - Cavity Insulation (mm)	System width (mm) excluding finishes	System code & Maximum height ¹ (mm) @ 600mm centres	System code & Maximum height ¹ (mm) @ 400mm centres	System code & Maximum height ¹ (mm) @ 300mm centres	Fire resistance period ² (minutes)	Acoustic Sound Insulation ³ (dB Rw)	Deflection allowance (mm)	Deflection head arrangement			
92 'C' Stud (0.70)	1	12.5	Performance Plus	Non Insulated	119	BS-PC-92-070-6-1-12.5-PP-0	4900	BS-PC-92-070-4-1-12.5-PP-0	5300	BS-PC-92-070-3-1-12.5-PP-0	5600	30	38	-25	Figure 1
	1	12.5	Performance Plus	Non Insulated	119	BS-PC-92-070-6-1-12.5-PP-0	4900	BS-PC-92-070-4-1-12.5-PP-0	5300	BS-PC-92-070-3-1-12.5-PP-0	5600	30	38	-50	Figure 5
	1	12.5	Performance Plus	25	119	BS-PC-92-070-6-1-12.5-PP-25	4900	BS-PC-92-070-4-1-12.5-PP-25	5300	BS-PC-92-070-3-1-12.5-PP-25	5600	30	45	-25	Figure 3
	1	12.5	Performance Plus	25	119	BS-PC-92-070-6-1-12.5-PP-25	4900	BS-PC-92-070-4-1-12.5-PP-25	5300	BS-PC-92-070-3-1-12.5-PP-25	5600	30	45	-50	Figure 7
	1	15	Performance Plus	Non Insulated	124	BS-PC-92-070-6-1-15-PP-0	5100	BS-PC-92-070-4-1-15-PP-0	5400	BS-PC-92-070-3-1-15-PP-0	5800	60	40	-25	Figure 9
	1	15	Performance Plus	Non Insulated	124	BS-PC-92-070-6-1-15-PP-0	5100	BS-PC-92-070-4-1-15-PP-0	5400	BS-PC-92-070-3-1-15-PP-0	5800	60	40	-50	Figure 10
	1	15	Performance Plus	25	124	BS-PC-92-070-6-1-15-PP-25	5100	BS-PC-92-070-4-1-15-PP-25	5400	BS-PC-92-070-3-1-15-PP-25	5800	60	47	-25	Figure 11
	1	15	Performance Plus	25	124	BS-PC-92-070-6-1-15-PP-25	5100	BS-PC-92-070-4-1-15-PP-25	5400	BS-PC-92-070-3-1-15-PP-25	5800	60	47	-50	Figure 12
	2	12.5	Performance Plus	Non Insulated	144	BS-PC-92-070-6-2-12.5-PP-0	5700	BS-PC-92-070-4-2-12.5-PP-0	6100	BS-PC-92-070-3-2-12.5-PP-0	6300	120	48	-25	Figure 13
	2	12.5	Performance Plus	Non Insulated	144	BS-PC-92-070-6-2-12.5-PP-0	5700	BS-PC-92-070-4-2-12.5-PP-0	6100	BS-PC-92-070-3-2-12.5-PP-0	6300	120	48	-50	Figure 15
	2	12.5	Performance Plus	25	144	BS-PC-92-070-6-2-12.5-PP-25	5700	BS-PC-92-070-4-2-12.5-PP-25	6100	BS-PC-92-070-3-2-12.5-PP-25	6300	120	53	-25	Figure 14
	2	12.5	Performance Plus	25	144	BS-PC-92-070-6-2-12.5-PP-25	5700	BS-PC-92-070-4-2-12.5-PP-25	6100	BS-PC-92-070-3-2-12.5-PP-25	6300	120	53	-50	Figure 16
	2	15	Performance Plus	Non Insulated	154	BS-PC-92-070-6-2-15-PP-0	6000	BS-PC-92-070-4-2-15-PP-0	6300	BS-PC-92-070-3-2-15-PP-0	6600	48	52	-25	Figure 13
	2	15	Performance Plus	Non Insulated	154	BS-PC-92-070-6-2-15-PP-0	6000	BS-PC-92-070-4-2-15-PP-0	6300	BS-PC-92-070-3-2-15-PP-0	6600	48	52	-50	Figure 15
	2	15	Performance Plus	25	154	BS-PC-92-070-6-2-15-PP-25	6000	BS-PC-92-070-4-2-15-PP-25	6300	BS-PC-92-070-3-2-15-PP-25	6600	60*	54	-25	Figure 14
	2	15	Performance Plus	25	154	BS-PC-92-070-6-2-15-PP-25	6000	BS-PC-92-070-4-2-15-PP-25	6300	BS-PC-92-070-3-2-15-PP-25	6600	60*	54	-50	Figure 16

146mm Stud Solutions

Knauf Stud depth and gauge (mm)	Knauf Plasterboard layers to each side of Knauf Stud (no)	Thickness of Knauf Plasterboard (mm)	Knauf Plasterboard	Knauf Insulation Acoustic Roll - Cavity Insulation (mm)	System width (mm) excluding finishes	System code & Maximum height ¹ (mm) @ 600mm centres	System code & Maximum height ¹ (mm) @ 400mm centres	System code & Maximum height ¹ (mm) @ 300mm centres	Fire resistance period ² (minutes)	Acoustic Sound Insulation ³ (dB Rw)	Deflection allowance (mm)	Deflection head arrangement			
146 'C' Stud (0.55)	1	12.5	Performance Plus	Non Insulated	173	BS-PC-146-055-6-1-12.5-PP-0	5600	BS-PC-146-055-4-1-12.5-PP-0	6400	BS-PC-146-055-3-1-12.5-PP-0	7000	30	38	-25	Figure 1
	1	12.5	Performance Plus	Non Insulated	173	BS-PC-146-055-6-1-12.5-PP-0	5600	BS-PC-146-055-4-1-12.5-PP-0	6400	BS-PC-146-055-3-1-12.5-PP-0	7000	30	38	-50	Figure 5
	1	12.5	Performance Plus	25	173	BS-PC-146-055-6-1-12.5-PP-25	5600	BS-PC-146-055-4-1-12.5-PP-25	6400	BS-PC-146-055-3-1-12.5-PP-25	7000	30	45	-25	Figure 3
	1	12.5	Performance Plus	25	173	BS-PC-146-055-6-1-12.5-PP-25	5600	BS-PC-146-055-4-1-12.5-PP-25	6400	BS-PC-146-055-3-1-12.5-PP-25	7000	30	45	-50	Figure 7
	1	15	Performance Plus	Non Insulated	178	BS-PC-146-055-6-1-15-PP-0	5800	BS-PC-146-055-4-1-15-PP-0	6700	BS-PC-146-055-3-1-15-PP-0	7200	60	44	-25	Figure 9
	1	15	Performance Plus	Non Insulated	178	BS-PC-146-055-6-1-15-PP-0	5800	BS-PC-146-055-4-1-15-PP-0	6700	BS-PC-146-055-3-1-15-PP-0	7200	60	44	-50	Figure 10
	1	15	Performance Plus	25	178	BS-PC-146-055-6-1-15-PP-25	5800	BS-PC-146-055-4-1-15-PP-25	6700	BS-PC-146-055-3-1-15-PP-25	7200	60	47	-25	Figure 11
	1	15	Performance Plus	25	178	BS-PC-146-055-6-1-15-PP-25	5800	BS-PC-146-055-4-1-15-PP-25	6700	BS-PC-146-055-3-1-15-PP-25	7200	60	47	-50	Figure 12
	2	12.5	Performance Plus	Non Insulated	198	BS-PC-146-055-6-2-12.5-PP-0	6300	BS-PC-146-055-4-2-12.5-PP-0	7500	BS-PC-146-055-3-2-12.5-PP-0	7900	120	48	-25	Figure 13
	2	12.5	Performance Plus	Non Insulated	198	BS-PC-146-055-6-2-12.5-PP-0	6300	BS-PC-146-055-4-2-12.5-PP-0	7500	BS-PC-146-055-3-2-12.5-PP-0	7900	120	48	-50	Figure 15
	2	12.5	Performance Plus	25	198	BS-PC-146-055-6-2-12.5-PP-25	6300	BS-PC-146-055-4-2-12.5-PP-25	7500	BS-PC-146-055-3-2-12.5-PP-25	7900	120	53	-25	Figure 14
	2	12.5	Performance Plus	25	198	BS-PC-146-055-6-2-12.5-PP-25	6300	BS-PC-146-055-4-2-12.5-PP-25	7500	BS-PC-146-055-3-2-12.5-PP-25	7900	120	53	-50	Figure 16
	2	15	Performance Plus	Non Insulated	208	BS-PC-146-055-6-2-15-PP-0	6600	BS-PC-146-055-4-2-15-PP-0	7900	BS-PC-146-055-3-2-15-PP-0	8300	120	52	-25	Figure 13
	2	15	Performance Plus	Non Insulated	208	BS-PC-146-055-6-2-15-PP-0	6600	BS-PC-146-055-4-2-15-PP-0	7900	BS-PC-146-055-3-2-15-PP-0	8300	120	52	-50	Figure 15
	2	15	Performance Plus	25	208	BS-PC-146-055-6-2-15-PP-25	6600	BS-PC-146-055-4-2-15-PP-25	7900	BS-PC-146-055-3-2-15-PP-25	8300	60*	54	-25	Figure 14
	2	15	Performance Plus	25	208	BS-PC-146-055-6-2-15-PP-25	6600	BS-PC-146-055-4-2-15-PP-25	7900	BS-PC-146-055-3-2-15-PP-25	8300	60*	54	-50	Figure 16

*System performance based on single layer system

- 1. Maximum height for BS Compliance Systems:** The stated maximum height figure is based on the maximum cold state height, calculated to limiting deflection of L/240 @ 200 Pascals.
- 2. Fire resistance period:** Tested in accordance with BS EN 1364-1. Fire resistance period is inclusive of fire integrity and fire insulation (EI). Fire resistance performance must be reviewed against Knauf specifications and standard details.
- 3. Acoustic sound insulation:** Tested or assessed in accordance with BS EN ISO 10140-1 and BS EN 10140-2. Important - Acoustic Sound Insulation Performance based on Knauf studs at 600mm centres and non-deflection arrangement. Systems that are fire resistance and / or offering acoustic sound performance must have all outer joints taped and filled in accordance with Knauf recommendations. Systems are tested as imperforate.

BS Compliance Specifications

Knauf Performer - MW Acoustic Stud - Soundshield Plus (BS Compliance)



Got a question? Email our Technical Service on technical-uk@knauf.com or call 0800 521050 (option 2)

70mm Stud Solutions

Knauf Stud depth and gauge (mm)	Knauf Plasterboard layers to each side of Knauf Stud (no)	Thickness of Knauf Plasterboard (mm)	Knauf Plasterboard	Knauf Insulation Acoustic Roll - Cavity Insulation (mm)	System width (mm) excluding finishes	System code & Maximum height ¹ (mm) @ 600mm centres	System code & Maximum height ¹ (mm) @ 400mm centres	System code & Maximum height ¹ (mm) @ 300mm centres	Fire resistance period ² (minutes)	Acoustic Sound Insulation ³ (dB Rw)	Acoustic Sound Insulation ³ (Rw + Ctr) dB	Deflection allowance (mm)	Deflection head arrangement			
70 'MW' Acoustic Studs (0.55)	2	12.5	Soundshield Plus	50	122	BS-PMW-70-055-6-2-12.5-SSP-50	4500	BS-PMW-70-055-4-2-12.5-SSP-50	4700	BS-PMW-70-055-3-2-12.5-SSP-50	4900	60	57	50	-25	Figure 4
	2	12.5	Soundshield Plus	50	122	BS-PMW-70-055-6-2-12.5-SSP-50	4500	BS-PMW-70-055-4-2-12.5-SSP-50	4700	BS-PMW-70-055-3-2-12.5-SSP-50	4900	60	57	50	-50	Figure 8
	2	15	Soundshield Plus	50	132	BS-PMW-70-055-6-2-15-SSP-50*	4800	BS-PMW-70-055-4-2-15-SSP-50*	5000	BS-PMW-70-055-3-2-15-SSP-50*	5200	90	57	52	-25	Figure 4
	2	15	Soundshield Plus	50	132	BS-PMW-70-055-6-2-15-SSP-50*	4800	BS-PMW-70-055-4-2-15-SSP-50*	5000	BS-PMW-70-055-3-2-15-SSP-50*	5200	90	57	52	-50	Figure 8
	2	15	Soundshield Plus	50	132	BS-PMW-70-055-6-2-15-SSP-50**	4800	BS-PMW-70-055-4-2-15-SSP-50**	5000	BS-PMW-70-055-3-2-15-SSP-50**	5200	120	57	52	-25	Figure 14
	2	15	Soundshield Plus	50	132	BS-PMW-70-055-6-2-15-SSP-50**	4800	BS-PMW-70-055-4-2-15-SSP-50**	5000	BS-PMW-70-055-3-2-15-SSP-50**	5200	120	57	52	-50	Figure 16

* (90) ** (120)

92mm Stud Solutions

Knauf Stud depth and gauge (mm)	Knauf Plasterboard layers to each side of Knauf Stud (no)	Thickness of Knauf Plasterboard (mm)	Knauf Plasterboard	Knauf Insulation Acoustic Roll - Cavity Insulation (mm)	System width (mm) excluding finishes	System code & Maximum height ¹ (mm) @ 600mm centres	System code & Maximum height ¹ (mm) @ 400mm centres	System code & Maximum height ¹ (mm) @ 300mm centres	Fire resistance period ² (minutes)	Acoustic Sound Insulation ³ (dB Rw)	Acoustic Sound Insulation ³ (Rw + Ctr) dB	Deflection allowance (mm)	Deflection head arrangement			
92 'MW' Acoustic Studs (0.55)	2	12.5	Soundshield Plus	50	144	BS-PMW-92-055-6-2-12.5-SSP-50	5500	BS-PMW-92-055-4-2-12.5-SSP-50	5800	BS-PMW-92-055-3-2-12.5-SSP-50	6100	60	57	50	-25	Figure 4
	2	12.5	Soundshield Plus	50	144	BS-PMW-92-055-6-2-12.5-SSP-50	5500	BS-PMW-92-055-4-2-12.5-SSP-50	5800	BS-PMW-92-055-3-2-12.5-SSP-50	6100	60	57	50	-50	Figure 8
	2	15	Soundshield Plus	50	154	BS-PMW-92-055-6-2-15-SSP-50*	5900	BS-PMW-92-055-4-2-15-SSP-50*	6100	BS-PMW-92-055-3-2-15-SSP-50*	6300	90	57	52	-25	Figure 4
	2	15	Soundshield Plus	50	154	BS-PMW-92-055-6-2-15-SSP-50*	5900	BS-PMW-92-055-4-2-15-SSP-50*	6100	BS-PMW-92-055-3-2-15-SSP-50*	6300	90	57	52	-50	Figure 8
	2	15	Soundshield Plus	50	154	BS-PMW-92-055-6-2-15-SSP-50**	5900	BS-PMW-92-055-4-2-15-SSP-50**	6100	BS-PMW-92-055-3-2-15-SSP-50**	6300	120	57	52	-25	Figure 14
	2	15	Soundshield Plus	50	154	BS-PMW-92-055-6-2-15-SSP-50**	5900	BS-PMW-92-055-4-2-15-SSP-50**	6100	BS-PMW-92-055-3-2-15-SSP-50**	6300	120	57	52	-50	Figure 16

* (90) ** (120)

1. Maximum height for BS Compliance Systems: The stated maximum height figure is based on the maximum cold state height, calculated to limiting deflection of L/240 @ 200 Pascals.
2. Fire resistance period: Tested in accordance with BS EN 1364-1. Fire resistance period is inclusive of fire integrity and fire insulation (EI). Fire resistance performance must be reviewed against Knauf specifications and standard details.
3. Acoustic sound insulation: Tested or assessed in accordance with BS EN ISO 10140-1 and BS EN 10140-2. Important - Acoustic Sound Insulation Performance based on Knauf studs at 600mm centres and non-deflection arrangement. Systems that are fire resistance and / or offering acoustic sound performance must have all outer joints taped and filled in accordance with Knauf recommendations. Systems are tested as imperforate.

Knauf Performer - Partition with Knauf Resilient Bar (BS Compliance)



Got a question? Email our Technical Service on technical-uk@knauf.com or call 0800 521050 (option 2)

70mm Stud Solutions

Knauf Stud depth and gauge (mm)	Knauf Plasterboard layers to each side of Knauf Stud (no)	Thickness of Knauf Plasterboard (mm)	Knauf Plasterboard	Knauf Resilient Bar	Knauf Insulation Acoustic Roll - Cavity Insulation (mm)	System width (mm) excluding finishes	Knauf Stud centres (mm)	System code & Maximum height ¹ (mm)	Fire resistance period ² (minutes)	Acoustic Sound Insulation ³ (dB Rw)	Acoustic Sound Insulation ³ (Rw + Ctr) dB	Deflection allowance (mm)	Deflection head arrangement	
70 'C' Stud (0.55)	2	15	Soundshield Plus	Fixed to one side spanning across Knauf Stud Studs at 600mm vertical centres	50	148	600	BS-PC-RB1-70-055-6-2-15-SSP-50(60)	4200	60	60	55	-25	Figure 19
	2	15	Soundshield Plus	Fixed to one side spanning across Knauf Stud Studs at 600mm vertical centres	50	148	600	BS-PC-RB1-70-055-6-2-15-SSP-50(60)	4200	60	60	55	-50	Figure 21
	2	15	Soundshield Plus	Fixed to one side spanning across Knauf Stud Studs at 600mm vertical centres	50	148	600	BS-PC-RB1-70-055-6-2-15-SSP-50(120)	4200	120	60	55	-25	Figure 20
	2	15	Soundshield Plus	Fixed to one side spanning across Knauf Stud Studs at 600mm vertical centres	50	148	600	BS-PC-RB1-70-055-6-2-15-SSP-50(120)	4200	120	60	55	-50	Figure 22

- 1. Maximum height for BS Compliance Systems:** The stated maximum height figure is based on the maximum cold state height, calculated to limiting deflection of L/240 @ 200 Pascals.
- 2. Fire resistance period:** Tested in accordance with BS EN 1364-1. Fire resistance period is inclusive of fire integrity and fire insulation (EI). Fire resistance performance must be reviewed against Knauf specifications and standard details.
- 3. Acoustic sound insulation:** Tested or assessed in accordance with BS EN ISO 10140-1 and BS EN 10140-2. Important - Acoustic Sound Insulation Performance based on Knauf studs at 600mm centres and non-deflection arrangement. Systems that are fire resistance and / or offering acoustic sound performance must have all outer joints taped and filled in accordance with Knauf recommendations. Systems are tested as imperforate.

Knauf AQUAPANEL® Interior System (BS Compliance)

70mm Stud Solutions

Knauf Stud depth and gauge (mm)	Knauf Plasterboard layers to each side of Knauf Stud (no)	Thickness of Knauf Plasterboard (mm)	Knauf Cement Board	Knauf Insulation Acoustic Roll - Cavity Insulation (mm)	System width (mm) excluding finishes	Knauf Stud centres (mm)	System code & Maximum height ¹ (mm)	Fire resistance period ² (minutes)	Acoustic Sound Insulation ³ (dB Rw)	Deflection allowance (mm)	Deflection head arrangement
70 'C' Stud (0.55)	1	12.5	AQUAPANEL® Indoor	25	97	600	BS-PAC-70-060-6-1-12.5-AQP-25	3000	Not Tested	-25	Figure 23
						400	BS-PAC-70-060-4-1-12.5-AQP-25	3300			
						300	BS-PAC-70-060-3-1-12.5-AQP-25	3600			

- 1. Maximum height for BS Compliance Systems:** The stated maximum height figure is the maximum cold state height, calculated to limiting deflection of L/500 @ 200 Pascals.
- 2. Fire resistance period:** Tested in accordance with BS EN 1364-1. Fire resistance period is inclusive of fire integrity and fire insulation (EI). Fire resistance performance must be reviewed against Knauf specifications and standard details.
- 3. Acoustic sound insulation:** Tested or assessed in accordance with BS EN ISO 10140-1 and BS EN 10140-2. Important - Acoustic Sound Insulation Performance based on Knauf studs at 600mm centres and non-deflection arrangement. Systems that are fire resistance and / or offering acoustic sound performance must have all outer joints taped and filled in accordance with Knauf recommendations. Systems are tested as imperforate.

Knauf Isolator - Twin Frame Partitions (BS Compliance)



Got a question? Email our Technical Service on technical-uk@knauf.com or call 0800 521050 (option 2)

50/60/70mm Stud Solutions (-25mm Deflection Allowance)

Knauf Stud depth and gauge (mm)	Knauf Plasterboard layers to each side of Knauf Stud (no)	Thickness of Knauf Plasterboard (mm)	Knauf Plasterboard (Inner layer - both sides)	Knauf Plasterboard (Outer layer - both sides)	Bracing required*	Knauf Insulation Acoustic Roll - Cavity Insulation (mm)	System width (mm) excluding finishes	Knauf Stud centres (mm)	System code & Maximum height ¹ (mm)	Fire resistance period ² (minutes)	Acoustic Sound Insulation ³ (dB Rw)	Acoustic Sound Insulation ³ (Rw + Ctr) dB	Deflection allowance (mm)	Deflection head arrangement		
Double 50 'C' (0.55)	2	15	Soundshield Plus	Soundshield Plus	Yes	2 x 25	170	600	BS-ICB-50-055-6-2-15-SSP-2x25(170/90)	4000	90	58	51	-25	Figure 24	
								400	BS-ICB-50-055-4-2-15-SSP-2x25(170/90)	4000						
								300	BS-ICB-50-055-3-2-15-SSP-2x25(170/90)	4000						
Double 50 'I' (0.55)	2	15	Soundshield Plus	Soundshield Plus	No	1 x 50	200	600	BS-II-50-055-6-2-15-SSP-1x50(200/120)	2900	120	62	56	-25	Figure 28	
								400	BS-II-50-055-4-2-15-SSP-1x50(200/120)	3300						
								300	BS-II-50-055-3-2-15-SSP-1x50(200/120)	3600						
Double 60 'I' (0.55)	2	15	Soundshield Plus	Soundshield Plus	No	1 x 50	220	600	BS-II-60-055-6-2-15-SSP-1x50(220/120)	3300	120	62	56	-25	Figure 28	
								400	BS-II-60-055-4-2-15-SSP-1x50(220/120)	3700						
								300	BS-II-60-055-3-2-15-SSP-1x50(220/120)	4100						
Double 70 'C' (0.55)	2	15	Soundshield Plus	Soundshield Plus	No	2 x 25	229	600	BS-IC-70-055-6-2-15-SSP-2x25(229/60)	3000	60	65	60	-25	Figure 24	
								400	BS-IC-70-055-4-2-15-SSP-2x25(229/60)	3000						
								300	BS-IC-70-055-3-2-15-SSP-2x25(229/60)	3000						
	2	15	Soundshield Plus	Soundshield Plus	No	2 x 25	229	600	BS-IC-70-055-6-2-15-SSP-2x25(229/90)	3000	90	65	60	-25	Figure 24	
									400	BS-IC-70-055-4-2-15-SSP-2x25(229/90)						3000
									300	BS-IC-70-055-3-2-15-SSP-2x25(229/90)						3000
	2	15	Soundshield Plus	Soundshield Plus	No	2 x 25	229	600	BS-IC-70-055-6-2-15-SSP-2x25(229/120)	3000	120**	65	60	-25	Figure 26	
									400	BS-IC-70-055-4-2-15-SSP-2x25(229/120)						3000
									300	BS-IC-70-055-3-2-15-SSP-2x25(229/120)						3000
	2	15	Soundshield Plus	Soundshield Plus	Yes	2 x 25	214	600	BS-ICB-70-055-6-2-15-SSP-2x25(214/120)	7000	120	60	53	-25	Figure 26	
									400	BS-ICB-70-055-4-2-15-SSP-2x25(214/120)						8000
									300	BS-ICB-70-055-3-2-15-SSP-2x25(214/120)						9500
Double 70 'I' (0.70)	2	15	Soundshield Plus	Soundshield Plus	No	1 x 100	250	600	BS-II-70-070-6-2-15-SSP-1x100(250/120)	4000	120	66	61	-25	Figure 30	
								400	BS-II-70-070-4-2-15-SSP-1x100(250/120)	4600						
								300	BS-II-70-070-3-2-15-SSP-1x100(250/120)	5000						

*Bracing of double studs using Knauf Flat Plate at 1500mm vertical centres

**System fire resistance tested with the inclusion of baffle boxes

1. Maximum height for BS Compliance Systems: The stated maximum height figure is the lower value between maximum cold state height, calculated to limiting deflection of L/240 @ 200 Pascals and the fire state height, as outlined in accordance with BS EN 1364-1.

2. Fire resistance period: Tested in accordance with BS EN 1364-1. Fire resistance period is inclusive of fire integrity and fire insulation (EI). Fire resistance performance must be reviewed against Knauf specifications and standard details.

3. Acoustic sound insulation: Tested or assessed in accordance with BS EN ISO 10140-1 and BS EN 10140-2. Important - Acoustic Sound Insulation Performance based on Knauf studs at 600mm centres and non-deflection arrangement. Systems that are fire resistance and / or offering acoustic sound performance must have all outer joints taped and filled in accordance with Knauf recommendations. Systems are tested as imperforate.

Knauf Isolator - Twin Frame Partitions (BS Compliance)



Got a question? Email our Technical Service on technical-uk@knauf.com or call 0800 521050 (option 2)

50/60/70mm Stud Solutions (-50mm Deflection Allowance)

Knauf Stud depth and gauge (mm)	Knauf Plasterboard layers to each side of Knauf Stud (no)	Thickness of Knauf Plasterboard (mm)	Knauf Plasterboard (Inner layer - both sides)	Knauf Plasterboard (Outer layer - both sides)	Bracing required*	Knauf Insulation Acoustic Roll - Cavity Insulation (mm)	System width (mm) excluding finishes	Knauf Stud centres (mm)	System code & Maximum height ¹ (mm)	Fire resistance period ² (minutes)	Acoustic Sound Insulation ³ (dB Rw)	Acoustic Sound Insulation ³ (Rw + Ctr) dB	Deflection allowance (mm)	Deflection head arrangement		
Double 50 'C' (0.55)	2	15	Soundshield Plus	Soundshield Plus	Yes	2 x 25	170	600	BS-ICB-50-055-6-2-15-SSP-2x25(170/90)	4000	90	58	51	-50	Figure 32	
								400	BS-ICB-50-055-4-2-15-SSP-2x25(170/90)	4000						
								300	BS-ICB-50-055-3-2-15-SSP-2x25(170/90)	4000						
Double 50 'I' (0.55)	2	15	Soundshield Plus	Soundshield Plus	No	1 x 50	200	600	BS-II-50-055-6-2-15-SSP-1x50(200/120)	2900	120	62	56	-50	Figure 36	
								400	BS-II-50-055-4-2-15-SSP-1x50(200/120)	3300						
								300	BS-II-50-055-3-2-15-SSP-1x50(200/120)	3600						
Double 60 'I' (0.55)	2	15	Soundshield Plus	Soundshield Plus	No	1 x 50	220	600	BS-II-60-055-6-2-15-SSP-1x50(220/120)	3300	120	62	56	-50	Figure 36	
								400	BS-II-60-055-4-2-15-SSP-1x50(220/120)	3700						
								300	BS-II-60-055-3-2-15-SSP-1x50(220/120)	4100						
Double 70 'C' (0.55)	2	15	Soundshield Plus	Soundshield Plus	No	2 x 25	229	600	BS-IC-70-055-6-2-15-SSP-2x25(229/60)	3000	60	65	60	-50	Figure 32	
								400	BS-IC-70-055-4-2-15-SSP-2x25(229/60)	3000						
								300	BS-IC-70-055-3-2-15-SSP-2x25(229/60)	3000						
	2	15	Soundshield Plus	Soundshield Plus	No	2 x 25	229	600	BS-IC-70-055-6-2-15-SSP-2x25(229/90)	3000	90	65	60	-50	Figure 32	
									400	BS-IC-70-055-4-2-15-SSP-2x25(229/90)						3000
									300	BS-IC-70-055-3-2-15-SSP-2x25(229/90)						3000
	2	15	Soundshield Plus	Soundshield Plus	No	2 x 25	229	600	BS-IC-70-055-6-2-15-SSP-2x25(229/120)	3000	120**	65	60	-50	Figure 34	
									400	BS-IC-70-055-4-2-15-SSP-2x25(229/120)						3000
									300	BS-IC-70-055-3-2-15-SSP-2x25(229/120)						3000
	2	15	Soundshield Plus	Soundshield Plus	Yes	2 x 25	214	600	BS-ICB-70-055-6-2-15-SSP-2x25(214/120)	7000	120	60	53	-50	Figure 34	
									400	BS-ICB-70-055-4-2-15-SSP-2x25(214/120)						8000
									300	BS-ICB-70-055-3-2-15-SSP-2x25(214/120)						9500
Double 70 'I' (0.70)	2	15	Soundshield Plus	Soundshield Plus	No	1 x 100	250	600	BS-II-70-070-6-2-15-SSP-1x100(250/120)	4000	120	66	61	-50	Figure 38	
								400	BS-II-70-070-4-2-15-SSP-1x100(250/120)	4600						
								300	BS-II-70-070-3-2-15-SSP-1x100(250/120)	5000						

*Bracing of double studs using Knauf Flat Plate at 1500mm vertical centres

**System fire resistance tested with the inclusion of baffle boxes

1. **Maximum height for BS Compliance Systems:** The stated maximum height figure is the lower value between maximum cold state height, calculated to limiting deflection of L/240 @ 200 Pascals and the fire state height, as outlined in accordance with BS EN 1364-1.

2. **Fire resistance period:** Tested in accordance with BS EN 1364-1. Fire resistance period is inclusive of fire integrity and fire insulation (EI). Fire resistance performance must be reviewed against Knauf specifications and standard details.

3. **Acoustic sound insulation:** Tested or assessed in accordance with BS EN ISO 10140-1 and BS EN 10140-2. Important - Acoustic Sound Insulation Performance based on Knauf studs at 600mm centres and non-deflection arrangement. Systems that are fire resistance and / or offering acoustic sound performance must have all outer joints taped and filled in accordance with Knauf recommendations. Systems are tested as imperforate.

Knauf Isolator - Twin Frame Partitions - Hybrid (BS Compliance)



Got a question? Email our Technical Service on technical-uk@knauf.com or call 0800 521050 (option 2)

50/60/70mm Stud Solutions (-25mm Deflection Allowance)

Knauf Stud depth and gauge (mm)	Knauf Plasterboard layers to each side of Knauf Stud (no)	Thickness of Knauf Plasterboard (mm)	Knauf Plasterboard (Inner layer - both sides)	Knauf Plasterboard (Outer layer - both sides)	Bracing required*	Knauf Insulation Acoustic Roll - Cavity Insulation (mm)	System width (mm) excluding finishes	Knauf Stud centres (mm)	System code & Maximum height ¹ (mm)	Fire resistance period ² (minutes)	Acoustic Sound Insulation ³ (dB Rw)	Acoustic Sound Insulation ³ (Rw + Ctr) dB	Deflection allowance (mm)	Deflection head arrangement	
Double 50 'I' (0.55)	2	15	Soundshield Plus	Performance Plus	No	1 x 50	200	600	BS-II-50-055-6-1x15-SSP-1x15-PP-1x50(200/120)	2900	120	62	56	-25	Figure 29
								400	BS-II-50-055-4-1x15-SSP-1x15-PP-1x50(200/120)	3300					
								300	BS-II-50-055-3-1x15-SSP-1x15-PP-1x50(200/120)	3600					
Double 60 'I' (0.55)	2	15	Soundshield Plus	Performance Plus	No	1 x 50	220	600	BS-II-60-055-6-1x15-SSP-1x15-PP-1x50(220/120)	3300	120	62	56	-25	Figure 29
								400	BS-II-60-055-4-1x15-SSP-1x15-PP-1x50(220/120)	3700					
								300	BS-II-60-055-3-1x15-SSP-1x15-PP-1x50(220/120)	4100					
Double 70 'C' (0.55)	2	15	Soundshield Plus	Performance Plus	No	2 x 25	229	600	BS-IC-70-055-6-1x15-SSP-1x15-PP-2x25(229/60)	3000	60	65	60	-25	Figure 25
								400	BS-IC-70-055-4-1x15-SSP-1x15-PP-2x25(229/60)	3000					
								300	BS-IC-70-055-3-1x15-SSP-1x15-PP-2x25(229/60)	3000					
	2	15	Soundshield Plus	Performance Plus	No	2 x 25	229	600	BS-IC-70-055-6-1x15-SSP-1x15-PP-2x25(229/90)	3000	90	65	60	-25	Figure 25
								400	BS-IC-70-055-4-1x15-SSP-1x15-PP-2x25(229/90)	3000					
								300	BS-IC-70-055-3-1x15-SSP-1x15-PP-2x25(229/90)	3000					
	2	15	Soundshield Plus	Performance Plus	No	2 x 25	229	600	BS-IC-70-055-6-1x15-SSP-1x15-PP-2x25(229/120)	3000	120	65	60	-25	Figure 27
								400	BS-IC-70-055-4-1x15-SSP-1x15-PP-2x25(229/120)	3000					
								300	BS-IC-70-055-3-1x15-SSP-1x15-PP-2x25(229/120)	3000					
Double 70 'I' (0.70)	2	15	Soundshield Plus	Performance Plus	No	1 x 100	250	600	BS-II-70-070-6-1x15-SSP-1x15-PP-1x100(250/120)	4000	120	66	61	-25	Figure 31
								400	BS-II-70-070-4-1x15-SSP-1x15-PP-1x100(250/120)	4600					
								300	BS-II-70-070-3-1x15-SSP-1x15-PP-1x100(250/120)	5000					

*Bracing of double studs using Knauf Flat Plate at 1500mm vertical centres

1. Maximum height for BS Compliance Systems: The stated maximum height figure is the lower value between maximum cold state height, calculated to limiting deflection of L/240 @ 200 Pascals and the fire state height, as outlined in accordance with BS EN 1364-1.
2. Fire resistance period: Tested in accordance with BS EN 1364-1. Fire resistance period is inclusive of fire integrity and fire insulation (EI). Fire resistance performance must be reviewed against Knauf specifications and standard details.
3. Acoustic sound insulation: Tested or assessed in accordance with BS EN ISO 10140-1 and BS EN 10140-2. Important - Acoustic Sound Insulation Performance based on Knauf studs at 600mm centres and non-deflection arrangement. Systems that are fire resistance and/or offering acoustic sound performance must have all outer joints taped and filled in accordance with Knauf recommendations. Systems are tested as imperforate.

Knauf Isolator - Twin Frame Partitions - Hybrid (BS Compliance)



Got a question? Email our Technical Service on technical-uk@knauf.com or call 0800 521050 (option 2)

50/60/70mm Stud Solutions (-50mm Deflection Allowance)

Knauf Stud depth and gauge (mm)	Knauf Plasterboard layers to each side of Knauf Stud (no)	Thickness of Knauf Plasterboard (mm)	Knauf Plasterboard (Inner layer - both sides)	Knauf Plasterboard (Outer layer - both sides)	Bracing required*	Knauf Insulation Acoustic Roll - Cavity Insulation (mm)	System width (mm) excluding finishes	Knauf Stud centres (mm)	System code & Maximum height ¹ (mm)	Fire resistance period ² (minutes)	Acoustic Sound Insulation ³ (dB Rw)	Acoustic Sound Insulation ³ (Rw + Ctr) dB	Deflection allowance (mm)	Deflection head arrangement	
Double 50 'I' (0.55)	2	15	Soundshield Plus	Performance Plus	No	1 x 50	200	600	BS-II-50-055-6-1x15-SSP-1x15-PP-1x50(200/120)	2900	120	62	56	-50	Figure 37
								400	BS-II-50-055-4-1x15-SSP-1x15-PP-1x50(200/120)	3300					
								300	BS-II-50-055-3-1x15-SSP-1x15-PP-1x50(200/120)	3600					
Double 60 'I' (0.55)	2	15	Soundshield Plus	Performance Plus	No	1 x 50	220	600	BS-II-60-055-6-1x15-SSP-1x15-PP-1x50(220/120)	3300	120	62	56	-50	Figure 37
								400	BS-II-60-055-4-1x15-SSP-1x15-PP-1x50(220/120)	3700					
								300	BS-II-60-055-3-1x15-SSP-1x15-PP-1x50(220/120)	4100					
Double 70 'C' (0.55)	2	15	Soundshield Plus	Performance Plus	No	2 x 25	229	600	BS-IC-70-055-6-1x15-SSP-1x15-PP-2x25(229/60)	3000	60	65	60	-50	Figure 33
								400	BS-IC-70-055-4-1x15-SSP-1x15-PP-2x25(229/60)	3000					
								300	BS-IC-70-055-3-1x15-SSP-1x15-PP-2x25(229/60)	3000					
	2	15	Soundshield Plus	Performance Plus	No	2 x 25	229	600	BS-IC-70-055-6-1x15-SSP-1x15-PP-2x25(229/90)	3000	90	65	60	-50	Figure 33
								400	BS-IC-70-055-4-1x15-SSP-1x15-PP-2x25(229/90)	3000					
								300	BS-IC-70-055-3-1x15-SSP-1x15-PP-2x25(229/90)	3000					
	2	15	Soundshield Plus	Performance Plus	No	2 x 25	229	600	BS-IC-70-055-6-1x15-SSP-1x15-PP-2x25(229/120)	3000	120	65	60	-50	Figure 35
								400	BS-IC-70-055-4-1x15-SSP-1x15-PP-2x25(229/120)	3000					
								300	BS-IC-70-055-3-1x15-SSP-1x15-PP-2x25(229/120)	3000					
Double 70 'I' (0.70)	2	15	Soundshield Plus	Performance Plus	No	1 x 100	250	600	BS-II-70-070-6-1x15-SSP-1x15-PP-1x100(250/120)	4000	120	66	61	-50	Figure 39
								400	BS-II-70-070-4-1x15-SSP-1x15-PP-1x100(250/120)	4600					
								300	BS-II-70-070-3-1x15-SSP-1x15-PP-1x100(250/120)	5000					

*Bracing of double studs using Knauf Flat Plate at 1500mm vertical centres

1. Maximum height for BS Compliance Systems: The stated maximum height figure is the lower value between maximum cold state height, calculated to limiting deflection of L/240 @ 200 Pascals and the fire state height, as outlined in accordance with BS EN 1364-1.
2. Fire resistance period: Tested in accordance with BS EN 1364-1. Fire resistance period is inclusive of fire integrity and fire insulation (EI). Fire resistance performance must be reviewed against Knauf specifications and standard details.
3. Acoustic sound insulation: Tested or assessed in accordance with BS EN ISO 10140-1 and BS EN 10140-2. Important - Acoustic Sound Insulation Performance based on Knauf studs at 600mm centres and non-deflection arrangement. Systems that are fire resistance and/or offering acoustic sound performance must have all outer joints taped and filled in accordance with Knauf recommendations. Systems are tested as imperforate.

Knauf Shaftwall (BS Compliance)



Got a question? Email our Technical Service on technical-uk@knauf.com or call 0800 521050 (option 2)

60/92/146mm Stud Solutions

Knauf Stud depth and gauge (mm)	Knauf Plasterboards to lobby/room side	Integral Knauf Plasterboard to shaft side	Knauf Insulation Acoustic Roll - Cavity Insulation (mm)	System width (mm) excluding finishes	Knauf Stud centres (mm)	System code & Maximum height ¹ (mm)	Fire resistance period ² (minutes)	Acoustic Sound Insulation ³ (dB Rw)	Deflection allowance (mm)	Deflection head arrangement	
60 'CT' Stud (0.92)	2 x 12.5mm Knauf Fire Panel	19mm Coreboard	Non insulated	87	600	BS-SW-CT-60-092-6-2x12.5-FP-0	4000	60	Non Tested	-25	Figure 40
	2 x 12.5mm Knauf Fire Panel	19mm Coreboard	Non insulated	87	600	BS-SW-CT-60-092-6-2x12.5-FP-0	4000	60	Non Tested	-50	Figure 43
	2 x 15mm Knauf Fire Panel	19mm Coreboard	Non insulated	92	600	BS-SW-CT-60-092-6-2x15-FP-0	4000	90	Non Tested	-25	Figure 41
	2 x 15mm Knauf Fire Panel	19mm Coreboard	Non insulated	92	600	BS-SW-CT-60-092-6-2x15-FP-0	4000	90	Non Tested	-50	Figure 44
	3 x 15mm Knauf Fire Panel	19mm Coreboard	Non insulated	107	600	BS-SW-CT-60-092-6-3x15-FP-0	4000	120	Non Tested	-25	Figure 42
	3 x 15mm Knauf Fire Panel	19mm Coreboard	Non insulated	107	600	BS-SW-CT-60-092-6-3x15-FP-0	4000	120	Non Tested	-50	Figure 45
	3 x 15mm Knauf Fire Panel	19mm Coreboard	25	107	600	BS-SW-CT-60-092-6-3x15-FP-25	4000	120	50	-25	Figure 42
	3 x 15mm Knauf Fire Panel	19mm Coreboard	25	107	600	BS-SW-CT-60-092-6-3x15-FP-25	4000	120	50	-50	Figure 45
92 'CT' Stud (0.92)	2 x 12.5mm Knauf Fire Panel	19mm Coreboard	Non insulated	119	600	BS-SW-CT-92-092-6-2x12.5-FP-0	4000	60	Non Tested	-25	Figure 40
	2 x 12.5mm Knauf Fire Panel	19mm Coreboard	Non insulated	119	600	BS-SW-CT-92-092-6-2x12.5-FP-0	4000	60	Non Tested	-50	Figure 43
	2 x 15mm Knauf Fire Panel	19mm Coreboard	Non insulated	124	600	BS-SW-CT-92-092-6-2x15-FP-0	4000	90	Non Tested	-25	Figure 41
	2 x 15mm Knauf Fire Panel	19mm Coreboard	Non insulated	124	600	BS-SW-CT-92-092-6-2x15-FP-0	4000	90	Non Tested	-50	Figure 44
	3 x 15mm Knauf Fire Panel	19mm Coreboard	Non insulated	139	600	BS-SW-CT-92-092-6-3x15-FP-0	4000	120	Non Tested	-25	Figure 42
	3 x 15mm Knauf Fire Panel	19mm Coreboard	Non insulated	139	600	BS-SW-CT-92-092-6-3x15-FP-0	4000	120	Non Tested	-50	Figure 45
	3 x 15mm Knauf Fire Panel	19mm Coreboard	25	139	600	BS-SW-CT-92-092-6-3x15-FP-25	4000	120	50	-25	Figure 42
	3 x 15mm Knauf Fire Panel	19mm Coreboard	25	139	600	BS-SW-CT-92-092-6-3x15-FP-25	4000	120	50	-50	Figure 45
	3 x 15mm Knauf Fire Panel	19mm Coreboard	25	139	600	BS-SW-CT-92-092-6-3x15-FP-25(5m)	5000	90	50	-25	Figure 42
	3 x 15mm Knauf Fire Panel	19mm Coreboard	25	139	600	BS-SW-CT-92-092-6-3x15-FP-25(5m)	5000	90	50	-50	Figure 45
146 'CT' Stud (0.92)	2 x 12.5mm Knauf Fire Panel	19mm Coreboard	Non insulated	173	600	BS-SW-CT-146-092-6-2x12.5-FP-0	4000	60	Non Tested	-25	Figure 40
	2 x 12.5mm Knauf Fire Panel	19mm Coreboard	Non insulated	173	600	BS-SW-CT-146-092-6-2x12.5-FP-0	4000	60	Non Tested	-50	Figure 43
	2 x 15mm Knauf Fire Panel	19mm Coreboard	Non insulated	178	600	BS-SW-CT-146-092-6-2x15-FP-0	4000	90	Non Tested	-25	Figure 41
	2 x 15mm Knauf Fire Panel	19mm Coreboard	Non insulated	178	600	BS-SW-CT-146-092-6-2x15-FP-0	4000	90	Non Tested	-50	Figure 44
	3 x 15mm Knauf Fire Panel	19mm Coreboard	Non insulated	193	600	BS-SW-CT-146-092-6-3x15-FP-0	4000	120	Non Tested	-25	Figure 42
	3 x 15mm Knauf Fire Panel	19mm Coreboard	Non insulated	193	600	BS-SW-CT-146-092-6-3x15-FP-0	4000	120	Non Tested	-50	Figure 45
	3 x 15mm Knauf Fire Panel	19mm Coreboard	25	193	600	BS-SW-CT-146-092-6-3x15-FP-25	4000	120	50	-25	Figure 42
	3 x 15mm Knauf Fire Panel	19mm Coreboard	25	193	600	BS-SW-CT-146-092-6-3x15-FP-25	4000	120	50	-50	Figure 45
	3 x 15mm Knauf Fire Panel	19mm Coreboard	25	193	600	BS-SW-CT-146-092-6-3x15-FP-25(5m)	5000	90	50	-25	Figure 42
	3 x 15mm Knauf Fire Panel	19mm Coreboard	25	193	600	BS-SW-CT-146-092-6-3x15-FP-25(5m)	5000	90	50	-50	Figure 45

1. Maximum height for BS Compliance Systems: For all Knauf Shaftwall systems follows the requirements as outlined within BS EN 1364-1 and Direct Field of Application (DIAP). The stated maximum height figure is the lower value between the cold state height, calculated to limiting deflection of L/240 and the fire state height.

2. Fire resistance period: Tested in accordance with BS EN 1364-1. Fire resistance period is inclusive of fire integrity and fire insulation (EI). Fire resistance performance must be reviewed against Knauf specifications and standard details.

3. Acoustic sound insulation: Tested or assessed in accordance with BS EN ISO 10140-1 and BS EN 10140-2. Important - Acoustic Sound Insulation Performance based on Knauf studs at 600mm centres and non-deflection arrangement. Systems that are fire resistance and/or offering acoustic sound performance must have all outer joints taped and filled in accordance with Knauf recommendations. Systems are tested as imperforate.

Knauf 'I' Stud Linings - Fire Resistance Performance Systems (BS Compliance)



Got a question? Email our Technical Service on technical-uk@knauf.com or call 0800 521050 (option 2)

70/92mm Stud Solutions

Knauf Stud depth and gauge (mm)	Knauf plasterboards to room side	Knauf Insulation Rocksilks RS60 - Cavity Insulation (mm)	System width (mm) excluding finishes	Knauf Stud centres (mm)	System code & Maximum height ¹ (mm)	Fire resistance period ² (minutes)	Acoustic Sound Insulation ³ (dB Rw)	Deflection allowance (mm)	Deflection head arrangement	
70 'I' Stud (0.70)	2 x 15mm Fire Panel	50	102	600	BS-ISL-I-70-070-6-2x15-FP-50	4000	Not Tested	-25	Figure 44	
				400	BS-ISL-I-70-070-4-2x15-FP-50	4000				
				300	BS-ISL-I-70-070-3-2x15-FP-50	4000				
	2 x 15mm Fire Panel	50	102	600	BS-ISL-I-70-070-6-2x15-FP-50	4000	60	Not Tested	-50	Figure 45
				400	BS-ISL-I-70-070-4-2x15-FP-50	4000				
				300	BS-ISL-I-70-070-3-2x15-FP-50	4000				
92 'I' Stud (0.90)	2 x 15mm Fire Panel	50	124	600	BS-ISL-I-92-090-6-2x15-FP-50	5000	Not Tested	-25	Figure 44	
				400	BS-ISL-I-92-090-4-2x15-FP-50	5000				
				300	BS-ISL-I-92-090-3-2x15-FP-50	5000				
	2 x 15mm Fire Panel	50	124	600	BS-ISL-I-92-090-6-2x15-FP-50	5000	60	Not Tested	-50	Figure 45
				400	BS-ISL-I-92-090-4-2x15-FP-50	5000				
				300	BS-ISL-I-92-090-3-2x15-FP-50	5000				

1. Maximum height for BS Compliance Systems: The stated maximum height figure is the lower value between maximum cold state height, calculated to limiting deflection of L/240 @ 200 Pascals and the fire state height, as outlined in accordance with BS EN 1364-1.

2. Fire resistance period: Tested in accordance with BS EN 1364-1. Fire resistance period is inclusive of fire integrity and fire insulation (EI). Fire resistance performance must be reviewed against Knauf specifications and standard details.

3. Acoustic sound insulation: Tested or assessed in accordance with BS EN ISO 10140-1 and BS EN 10140-2. Important - Acoustic Sound Insulation Performance based on Knauf studs at 600mm centres and non-deflection arrangement. Systems that are fire resistance and/or offering acoustic sound performance must have all outer joints taped and filled in accordance with Knauf recommendations. Systems are tested as imperforate.

Knauf 'I' Stud Linings - Non-Fire Resistance Performance Systems (BS Compliance)



Got a question? Email our Technical Service on technical-uk@knauf.com or call 0800 521050 (option 2)

50/60/70/92/146mm Stud Solutions

Knauf Stud depth and gauge (mm)	Knauf Plasterboard layers to room side	Thickness of Knauf Plasterboard (mm)	Knauf plasterboard to room side*	Overall lining width (excluding finishes)	Maximum height ¹ with stud centres 600mm	Maximum height ¹ with stud centres 400mm	Maximum height ¹ with stud centres 300mm
50 'I' Stud (0.55)	1	12.5	Knauf plasterboard to suit specification	64.5	2900	3300	3600
	2	12.5	Knauf plasterboard to suit specification	77	2900	3300	3600
	1	15	Knauf plasterboard to suit specification	67	2900	3300	3600
	2	15	Knauf plasterboard to suit specification	82	2900	3300	3600
60 'I' Stud (0.70)	1	12.5	Knauf plasterboard to suit specification	74.5	3600	4100	4500
	2	12.5	Knauf plasterboard to suit specification	87	3600	4100	4500
	1	15	Knauf plasterboard to suit specification	77	3600	4100	4500
	2	15	Knauf plasterboard to suit specification	92	3600	4100	4500
70 'I' Stud (0.70)	1	12.5	Knauf plasterboard to suit specification	84.5	4000	4600	5000
	2	12.5	Knauf plasterboard to suit specification	97	4000	4600	5000
	1	15	Knauf plasterboard to suit specification	87	4000	4600	5000
	2	15	Knauf plasterboard to suit specification	102	4000	4600	5000
92 'I' Stud (0.90)	1	12.5	Knauf plasterboard to suit specification	106.5	5300	6100	6700
	2	12.5	Knauf plasterboard to suit specification	119	5300	6100	6700
	1	15	Knauf plasterboard to suit specification	109	5300	6100	6700
	2	15	Knauf plasterboard to suit specification	124	5300	6100	6700
146 'I' Stud (0.90)	1	12.5	Knauf plasterboard to suit specification	158.5	7500	8600	9400
	2	12.5	Knauf plasterboard to suit specification	173	7500	8600	9400
	1	15	Knauf plasterboard to suit specification	163	7500	8600	9400
	2	15	Knauf plasterboard to suit specification	178	7500	8600	9400

*Various Knauf plasterboards can be used for such system arrangement

Knauf Smokeshaft (BS Compliance)



Got a question? Email our Technical Service on technical-uk@knauf.com or call 0800 521050 (option 2)

60mm Stud Solution

Knauf Stud depth and gauge (mm)	Knauf number of layers and board to lobby side	Integral Knauf board to shaft side	Knauf Insulation Acoustic Roll - Cavity Insulation (mm)	System width (mm) excluding finishes	Knauf Stud centres (mm)	System code & Maximum height ¹ (mm)	Fire resistance period ² (minutes)	Acoustic Sound Insulation (dB Rw)	Deflection allowance (mm)	Deflection head arrangement	
60 'I' Stud (0.70)	3 x 15mm Fireboard	15mm Fireboard	Non Insulated	107	600	BS-SS-I-60-070-3x15-FB-0	4000	120	46	-25	Figure 46

1. Maximum height: The stated maximum height is the lower value between cold state height, calculated to a limiting deflection of L/240 @ 200 pascals and the fire state, as outlined in accordance with BS EN 1364-1 and Direct Field of Application (DIAP).

2. Fire resistance period: Tested in accordance with BS EN 1364-1. Fire resistance period is inclusive of fire integrity and fire insulation (EI). Fire resistance performance must be reviewed against Knauf specifications and standard details.

3. Acoustic sound insulation: Tested or assessed in accordance with BS EN ISO 10140-1 and BS EN 10140-2. Important - Acoustic Sound Insulation Performance based on Knauf studs at 600mm centres and non-deflection arrangement. Systems that are fire resistance and/or offering acoustic sound performance must have all outer joints taped and filled in accordance with Knauf recommendations. Systems are tested as imperforate.

Note: System has not been tested in accordance with BS EN 1366-8:2024. If your project requires conformity to this standard, use an alternative approved construction type.

Knauf Horizontal Shaftwall - Ceiling System (BS Compliance)

Knauf Stud depth and gauge (mm)	Knauf plasterboards to underside of double Knauf 'CT' Studs	Thickness of Knauf Plasterboard (mm)	Knauf Plasterboard	Knauf Insulation RocksilK® RS60 layed above double Knauf 'CT' Studs	System width (mm) excluding finishes	Knauf double stud joist centres (mm)	Knauf double stud joist centres (mm) and maximum ceiling span	Fire resistance period (minutes)
Double 92 'CT' Stud (0.92)	3	12.5	Fire Panel	50	181.5	600	HSW-2xCT-92-092-6-3x12.5-FP-50	4000 60

1. System performance stated is based on directions from below to above and above to below accordance with BS EN 1364-1.

Fire resistance period: Tested in accordance with BS EN 1364-1. Fire resistance period is inclusive of fire integrity and fire insulation (EI). Fire resistance performance must be reviewed against Knauf specifications and standard details.

Note 1: System that requires fire resistance performance must have the outer layer plasterboards joints taped and filled in accordance with Knauf recommendations. Systems are tested as imperforate.

Note 2: For substrate fixings, approved fixings are required to meet performance constraints. Site design team to agree the suitability of design and method of installation for the project.

Knauf Metal Furring (MF) Suspended Ceilings (BS Compliance)

Knauf Plasterboard	Fixing Method	Layers to underside of Knauf MF Ceiling Framework	Thickness (mm)	Knauf Insulation RocksilK RS45 (mm) within ceiling void	System Code	Fire Resistance Period ¹
Wallboard	Fixed to underside of Knauf MF Ceiling	1	12.5	0	MF-1-12.5-WB-0	Not tested
Wallboard	Fixed to underside of Knauf MF Ceiling	1	15	0	MF-1-15-WB-0	Not tested
Moisture Panel	Fixed to underside of Knauf MF Ceiling	1	12.5	0	MF-1-12.5-MP-0	Not tested
Moisture Panel	Fixed to underside of Knauf MF Ceiling	1	15	0	MF-1-15-MP-0	Not tested
Soundshield Plus	Fixed to underside of Knauf MF Ceiling	1	12.5	0	MF-1-12.5-SSP-0	Not tested
Soundshield Plus	Fixed to underside of Knauf MF Ceiling	1	15	0	MF-1-15-SSP-0	Not tested
Fire Panel	Fixed to underside of Knauf MF Ceiling	2	12.5	0	MF-2-12.5-FP-0	30
Fire Panel	Fixed to underside of Knauf MF Ceiling	2	15	30	MF-2-15-FP-30RS	60
Wallboard	Fixed to underside of Knauf MF Ceiling	2	12.5	30	MF-2-12.5-WB-30RS	30
Moisture Panel	Fixed to underside of Knauf MF Ceiling	2	12.5	30	MF-2-12.5-MP-30RS	30

1. Fire resistance period: Tested in accordance with BS EN 1364-2. Fire resistance period is inclusive of both fire integrity and fire insulation. Fire resistance performance must be reviewed against Knauf specifications and standard details. Systems that denote N/A indicate that system has not been fire resistance tested.

Note 1. System that require fire resistance and/or acoustic sound insulation performance must have all outer joints taped and filled in accordance with Knauf recommendations. Systems are tested as imperforate.

Note 2: For substrate fixings, approved fixings are required to meet performance constraint. Site design team to agree the suitability of design and method of installation suitability for the project.

SPECIALIST KNAUF ENCASEMENT SYSTEMS

FOR BOTH EN & BS COMPLIANCE PROJECTS

Our systems

- Knauf Framed Encasement System - Fire Panel
- Knauf Frameless Encasement System - Fireboard
- Table D.2 UK Beams (UKB) Dimensions to BS4 Part 1:2005
- Table D.3 UK Columns (UKB) Dimensions to BS4 Part 1:2005

Knauf Framed Encasement System - Fire Panel

The Knauf Framed Encasement System – Fire Panel can be used to protect load-bearing universal steel beams and universal steel columns for up to 120 minutes load-bearing capacity which has been tested in accordance with EN 13381-4. The system comprises of specialist Knauf metal components which are attached to the steels creating a substructure for the Knauf Fire Panel plasterboards to be fixed to using Knauf Drywall Screws. All plasterboard joints must be taped and filled using Knauf jointing compounds. The plasterboards can then be treated to the desired finish.

To help specify the required thickness and number of layers of Knauf Fire Panel for universal steel beams (UB or UKB) and universal steel columns (UC or UKC) with your required fire protection period (minutes) it is important to obtain the following:

1. The structural use and description of members and critical temperature of sections:

Within ASFP Yellow Book – Fire Protection for structural steel in buildings Volume 1, 6th Edition (2025), Table B.1 provides default limiting and critical temperatures for standard sections manufactured from carbon steel in accordance with EN 1993 and EN 1994. They have been compiled based upon structural loading limitations to utilisation (in fire) values of no greater than $\mu_0 = 0.6$ for all scenarios.

2. A/V or Hp/A Factor:

The rate of increase in temperature of a steel cross-section is determined by the ratio of the heated surface area (A) to the volume (V). This ratio, A/V, has units of m^{-1} and is known as the 'Section Factor'. Members with low section factors will heat up more slowly. In the UK, the term Hp/A has been used for many years to denote the section factor, in the European fire test standards the section factor is referred to as A/V. It should be noted that the terms A/V and Hp/A have very similar meaning. By obtaining the structural use and description of member, with detailed understanding of size, mass, and dimensions of member the A/V or Hp/A Factor can be found. Specific to the use of Knauf Framed Encasement System – Fire Panel to encapsulate UK Beams and UK Columns, refer to Table D.2 - UK Beams (UKB), [page 58](#), dimensions to BS4 Part 1: 2005 and Table D.3 - UK Columns (UKC), [page 61](#), dimensions to BS4 Part 1:2005.

Table B.1 – Default critical temperatures

Simple Description	Structural Use / Description of Member	Default critical temperature (°C)
3-sided beam	'I' section and Hollow section beams in bending supporting concrete slabs or composite slabs	580
4-sided beam	'I' section and Hollow section beams in bending not supporting concrete slabs	550
Hangers and tension braces	Members in tension only of any shape	550
Column (including Hollow Columns), trusses and other bracings	Compression members of any shape*	500

* Truss / bracing members are typically in tension but can also be under compression, dependent upon the load path. Therefore, the conservative compression member temperature is adopted. As per the recommendations of ASFP, Designers should be aware that Table NA.1 in the UK National Annex for EN 1993-1-2 may also be used to determine limiting steel temperatures for structural members with respect to their utilisation in fire and for compression members, their non-dimensional slenderness ratio.

Note 1: For other steel cases, please consult ASFP Yellow Book- Fire Protection for structural steel in buildings Volume 1, 6th Edition.

Note 2: Critical temperature of all sections should be fully evaluated by a detailed engineering calculation conducted by a competent person.

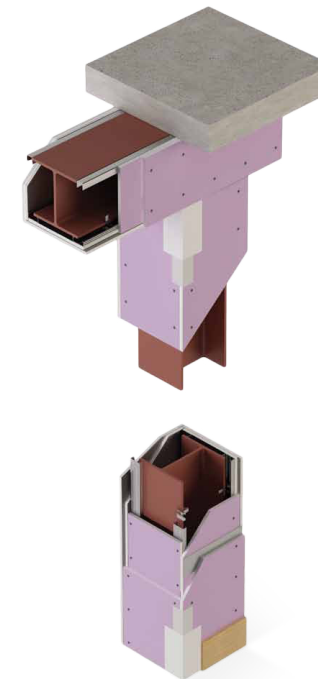

Tables A, B, C, and D, provide the Knauf plasterboard specification against the fire resistance period (minutes). The denoted A/V (Hp/A values) stated are the maximum acceptance for the specification solutions. Therefore, any universal steels less than or equal to this value allows you to specify the number and layers of Knauf Fire Panel.

Let's share an example:

You are required to provide fire protection (loadbearing capacity) of 60 minutes to a 3-sided 'I' section beam (254 x 102 x 22) in bending supporting concrete slabs. If the critical temperature is unknown, reference can be made to Table B.1 of the Yellow Book - ASFP Yellow Book – Fire Protection for structural steel in buildings Volume 1 6th Edition (2025), the default critical temperature is denoted as 580°C. As per Table D.2 a 254 x 102 x 22 Universal Beam requiring 3-sided boxed protection the A/V (Hp/A) is 220.

By cross referencing to Table C nearest table 550°C (≤580°C) it is acceptable to specify 2 x 12.5mm Knauf Fire Panel. The A/V (Hp/A) denoted must be greater or equal to the A/V (Hp/A) for the 254 x 102 x 22 Universal Beam.

Table A: Critical design temperature of 620°C

Knauf Plasterboard specification	Fire Resistance Period (minutes)			
	30	60	90	120
1 x 12.5mm Fire Panel	Hp/A 270	Hp/A 119		
1 x 15mm Fire Panel	Hp/A 270	Hp/A 187		
2 x 12.5mm Fire Panel		Hp/A 275	Hp/A 234	Hp/A 87
1 x 12.5mm + 1 x 15mm Fire Panel			Hp/A 275	Hp/A 111
2 x 15mm Fire Panel			Hp/A 275	Hp/A 159
1 x 12.5mm + 2 x 15mm Fire Panel				Hp/A 275

Table B: Critical design temperature of 600°C

Knauf Plasterboard specification	Fire Resistance Period (minutes)			
	30	60	90	120
1 x 12.5mm Fire Panel	Hp/A 270	Hp/A 112		
1 x 15mm Fire Panel	Hp/A 270	Hp/A 177		
2 x 12.5mm Fire Panel		Hp/A 275	Hp/A 226	Hp/A 84
1 x 12.5mm + 1 x 15mm Fire Panel			Hp/A 275	Hp/A 107
2 x 15mm Fire Panel			Hp/A 275	Hp/A 154
1 x 12.5mm + 2 x 15mm Fire Panel				Hp/A 275

Table C: Critical design temperature of 550°C

Knauf Plasterboard specification	Fire Resistance Period (minutes)			
	30	60	90	120
1 x 12.5mm Fire Panel	Hp/A 270	Hp/A 98		
1 x 15mm Fire Panel	Hp/A 270	Hp/A 155		
2 x 12.5mm Fire Panel		Hp/A 275	Hp/A 186	Hp/A 76
1 x 12.5mm + 1 x 15mm Fire Panel			Hp/A 275	Hp/A 94
2 x 15mm Fire Panel			Hp/A 275	Hp/A 135
1 x 12.5mm + 2 x 15mm Fire Panel				Hp/A 275

Table D: Critical design temperature of 500°C

Knauf Plasterboard specification	Fire Resistance Period (minutes)			
	30	60	90	120
1 x 12.5mm Fire Panel	Hp/A 270	Hp/A 84		
1 x 15mm Fire Panel	Hp/A 270	Hp/A 125		
2 x 12.5mm Fire Panel		Hp/A 275	Hp/A 138	Hp/A 63
1 x 12.5mm + 1 x 15mm Fire Panel		Hp/A 275	Hp/A 213	Hp/A 78
2 x 15mm Fire Panel			Hp/A 275	Hp/A 111
1 x 12.5mm + 2 x 15mm Fire Panel				Hp/A 275

Important

The critical temperatures of steel sections will vary on a project to project bases, dependent on location and intended use, and therefore you must consult with the structural engineer to gain confirmation the specific design temperatures that you need to use to help the determine your fire protection solution.

For further Knauf Framed Encasement System – Fire Panel solutions to support critical design temperature solutions less than 500°C, please contact our Technical Services, email: technical-uk@knauf.com or call **0800 521050**.

Knauf Frameless Encasement System - Fireboard

The Knauf Frameless Encasement System – Fireboard can be used to protect load-bearing universal steel beams and universal steel columns for up to 120 minutes load-bearing capacity which has been tested in accordance with EN 13381-4. The system comprises of Knauf Fireboard a fleece lined, glass reinforced gypsum board, fixed using stainless steel staples. To support decorative treatments, Knauf Fireboard Filler – Spatchel (Joint Filler and Finish) and Fibreglass Joint Tape available¹.

To help specify the required thickness and number of layers of Knauf Fireboard for universal steel beams (UB or UKB) and universal steel columns (UC or UKC) with your required fire protection period (minutes) it is important to obtain the following:

1. The structural use and description of members and critical temperature of sections:

Within ASFP Yellow Book – Fire Protection for structural steel in buildings Volume 1, 6th Edition (2025), Table B.1 provides default limiting and critical temperatures for standard sections manufactured from carbon steel in accordance with EN 1993 and EN 1994. They have been compiled based upon structural loading limitations to utilisation (in fire) values of no greater than $\mu_0 = 0.6$ for all scenarios.

2. A/V or Hp/A Factor

The rate of increase in temperature of a steel cross-section is determined by the ratio of the heated surface area (A) to the volume (V). This ratio, A/V, has units of m^{-1} and is known as the 'Section Factor'. Members with low section factors will heat up more slowly. In the UK, the term Hp/A has been used for many years to denote the section factor, in the European fire test standards the section factor is referred to as A/V. It should be noted that the terms A/V and Hp/A have very similar meaning.

By obtaining the structural use and description of member, with detailed understanding of size, mass, and dimensions of member the A/V or Hp/A Factor can be found. Specific to the use of Knauf Frameless Encasement System – Fireboard to encapsulate UK Beams and UK Columns, refer to Table D.2 - UK Beams (UKB), [page 58](#), dimensions to BS4 Part 1: 2005 and Table D.3 UK Columns (UKC), [page 61](#), dimensions to BS4 Part 1:2005.

Table B.1 - Default critical temperatures

Simple Description	Structural Use / Description of Member	Default critical temperature (°C)
3-sided beam	'I' section and Hollow section beams in bending supporting concrete slabs or composite slabs	580
4-sided beam	'I' section and Hollow section beams in bending not supporting concrete slabs	550
Hangers and tension braces	Members in tension only of any shape	550
Column (including Hollow Columns), trusses and other bracings	Compression members of any shape*	500

¹ Alternative Knauf Jointing Compounds and Tape are available to be used. Consult Technical Services for further information.

* Truss / bracing members are typically in tension but can also be under compression, dependent upon the load path. Therefore, the conservative compression member temperature is adopted. As per the recommendations of ASFP, Designers should be aware that Table NA.1 in the UK National Annex for EN 1993-1-2 may also be used to determine limiting steel temperatures for structural members with respect to their utilisation in fire and for compression members, their non-dimensional slenderness ratio.

Note 1: For other steel cases, please consult ASFP Yellow Book- Fire Protection for structural steel in buildings Volume 1, 6th Edition.

Note 2: Critical temperature of all sections should be fully evaluated by a detailed engineering calculation conducted by a competent person.



Tables A, B, C, and D, provide the Knauf Fireboard specification against the fire resistance period (minutes). The denoted A/V (Hp/A values) stated are the maximum acceptance for the specification solutions. Therefore, any universal steels less than or equal to this value allows you to specify the number and layers of Knauf Fireboard.

Let's share an example:

You are required to provide fire protection (loadbearing capacity) of 60 minutes to a 3-sided 'I' section beam (254 x 102 x 22) in bending supporting concrete slabs. If the critical temperature is unknown, reference can be made to Table B.1 of the Yellow Book - ASFP Yellow Book – Fire Protection for structural steel in buildings Volume 1, 6th Edition (2025), the default critical temperature is denoted as 580°C. As per Table D.2 a 254 x 102 x 22 Universal Beam, requiring 3-sided boxed protection the A/V (Hp/A) is 220.

By cross referencing to Table B, critical design temperature range of 580°C, it is acceptable to specify 1 x 20mm Knauf Fireboard. The A/V (Hp/A) denoted must be greater or equal to the A/V (Hp/A) for the 254 x 102 x 22 Universal Beam.

Table A: Critical design temperature of 620°C

Knauf Plasterboard specification	Fire Resistance Period (minutes)			
	30	60	90	120
1 x 15mm Knauf Fireboard		Hp/A 264	Hp/A 102	
1 x 20mm Knauf Fireboard		Hp/A 264	Hp/A 191	
2 x 15mm Knauf Fireboard		Hp/A 270	Hp/A 204	Hp/A 103
2 x 20mm Knauf Fireboard			Hp/A 270	Hp/A 238
2 x 25mm Knauf Fireboard				Hp/A 270

Table B: Critical design temperature of 580°C

Knauf Plasterboard specification	Fire Resistance Period (minutes)			
	30	60	90	120
1 x 15mm Knauf Fireboard	Hp/A 264	Hp/A 199	Hp/A 86	
1 x 20mm Knauf Fireboard		Hp/A 264	Hp/A 158	
2 x 15mm Knauf Fireboard		Hp/A 270	Hp/A 166	Hp/A 90
2 x 20mm Knauf Fireboard			Hp/A 270	Hp/A 198
2 x 25mm Knauf Fireboard				Hp/A 270

Table C: Critical design temperature of 550°C

Knauf Plasterboard specification	Fire Resistance Period (minutes)			
	30	60	90	120
1 x 15mm Knauf Fireboard	Hp/A 264	Hp/A 156	Hp/A 74	
1 x 20mm Knauf Fireboard		Hp/A 264	Hp/A 131	
2 x 15mm Knauf Fireboard		Hp/A 270	Hp/A 150	Hp/A 84
2 x 20mm Knauf Fireboard			Hp/A 270	Hp/A 171
2 x 25mm Knauf Fireboard				Hp/A 270

Table D: Critical design temperature of 500°C

Knauf Plasterboard specification	Fire Resistance Period (minutes)			
	30	60	90	120
1 x 15mm Knauf Fireboard	Hp/A 264	Hp/A 126	Hp/A 63	
1 x 20mm Knauf Fireboard	Hp/A 264	Hp/A 240	Hp/A 100	
2 x 15mm Knauf Fireboard		Hp/A 270	Hp/A 129	Hp/A 75
2 x 20mm Knauf Fireboard			Hp/A 270	Hp/A 141
2 x 25mm Knauf Fireboard				Hp/A 270

Important

The critical temperatures of steel sections will vary on a project to project bases, dependent on location and intended use, and therefore you must consult with the structural engineer to gain confirmation the specific design temperatures that you need to use to help the determine your fire protection solution.

For further Knauf Framed Encasement System – Fire Panel solutions to support critical design temperature solutions less than 500°C, please contact our Technical Services, email: technical-uk@knauf.com or call **0800 521050**.

Knauf Framed Encasement System - Fire Panel and Knauf Frameless Encasement System - Fireboard

Table D.2 UK Beams (UKB) Dimensions to BS4 Part 1:2005

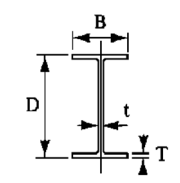

Designation	Depth of section D (mm)		Width of section B (mm)	Thickness		Area of section (cm ²)	Section factor A/V(Hp/A)			
	Serial size (mm)	Mass per metre (kg)		Web t (mm)	Flange T (mm)		Profile:		Box:	
							3 sides (m ⁻¹)	4 sides (m ⁻¹)	3 sides (m ⁻¹)	4 sides (m ⁻¹)
1016 x 305	487	1036.1	308.5	30.0	54.1	619.89	45	50	40	45
	438	1025.9	305.4	26.9	49.0	556.62	50	55	40	50
	393	1016.0	303.0	24.4	43.9	500.24	55	65	45	55
	349	1008.1	302.0	21.1	40.0	445.15	65	70	50	60
	314	1000.0	300.0	19.1	35.9	400.41	70	80	55	65
	272	990.1	300.0	16.5	31.0	346.86	80	90	65	75
	249	980.2	300.0	16.5	26.0	316.88	90	95	70	80
	222	970.3	300.0	16.0	21.1	282.82	95	110	80	90
914 x 419	388	921.0	420.5	21.4	36.6	494.22	60	70	45	55
	343	911.8	418.5	19.4	32.0	437.30	70	80	50	60
914 x 305	289	926.6	307.7	19.5	32.0	368.27	75	80	60	65
	253	918.4	305.5	17.3	27.9	322.83	85	95	65	75
	224	910.4	304.1	15.9	23.9	285.64	95	105	75	85
	201	903.0	303.3	15.1	20.2	255.92	105	115	80	95
838 x 292	226	850.9	293.8	16.1	26.8	288.56	85	100	70	80
	194	840.7	292.4	14.7	21.7	246.82	100	115	80	90
	176	834.9	291.7	14.0	18.8	224.02	110	125	90	100
762 x 267	197	769.8	268.0	15.6	25.4	250.64	90	100	70	85
	173	762.2	266.7	14.3	21.6	220.37	105	115	80	95
	147	754.0	265.2	12.8	17.5	187.19	120	135	95	110
	134	750.0	264.4	12.0	15.5	170.58	130	145	105	120
686 x 254	170	692.9	255.8	14.5	23.7	216.83	95	110	75	90
	152	687.5	254.5	13.2	21.0	194.08	105	120	85	95
	140	683.5	253.7	12.4	19.0	178.43	115	130	90	105
	125	677.9	253.0	11.7	16.2	159.48	130	145	100	115
610 x 305	238	635.8	311.4	18.4	31.4	303.33	70	80	50	60
	179	620.2	307.1	14.1	23.6	228.08	90	105	70	80
	149	612.4	304.8	11.8	19.7	190.04	110	125	80	95
610 x 229	140	617.2	230.2	13.1	22.1	178.19	105	120	80	95
	125	612.2	229.0	11.9	19.6	159.34	115	130	90	105
	113	607.6	228.2	11.1	17.3	143.94	130	145	100	115
	101	602.6	227.6	10.5	14.8	128.92	145	160	110	130
610 x 178	100	607.4	179.2	11.3	17.2	128.00	135	150	110	125
	92	603.0	178.8	10.9	15.0	117.00	145	160	120	135
	82	598.6	177.9	10.0	12.8	104.00	160	180	130	150

Specialist Knauf Encasement Systems (for both EN and BS compliance projects)

Table continued overleaf →

Tables are extracted from Annex D of ASFP Yellow Book - Fire Protection for structural steel in building Volume 1, 6th Edition.
The Knauf Framed Encasement System - Fire Panel and Knauf Frameless Encasement System - Fireboard is applicable to 'Box' Universal Steel Beams/Columns.

Knauf Framed Encasement System - Fire Panel and Knauf Frameless Encasement System - Fireboard

Table D.2 UK Beams (UKB) Dimensions to BS4 Part 1:2005

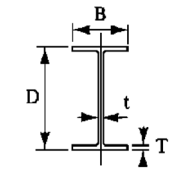

Designation	Depth of section D (mm)		Width of section B (mm)	Thickness		Area of section (cm ²)	Section factor A/V(Hp/A)			
	Serial size (mm)	Mass per metre (kg)		Web t (mm)	Flange T (mm)		Profile:		Box:	
							3 sides (m ⁻¹)	4 sides (m ⁻¹)	3 sides (m ⁻¹)	4 sides (m ⁻¹)
533 × 312	273	577.1	320.2	21.1	37.6	348.00	60	70	40	50
	219	560.3	317.4	18.3	29.2	279.00	70	85	50	65
	182	550.7	314.5	15.2	24.4	231.00	85	100	60	75
	151	542.5	312.0	12.7	20.3	192.00	105	120	75	90
533 × 210	138	549.1	213.9	14.7	23.6	176.00	95	110	75	85
	122	544.5	211.9	12.7	21.3	155.39	110	120	85	95
	109	539.5	210.8	11.6	18.8	138.86	120	135	95	110
	101	536.7	210.0	10.8	17.4	128.67	130	145	100	115
533 × 165	92	533.1	209.3	10.1	15.6	117.38	140	160	110	125
	82	528.3	208.8	9.6	13.2	104.69	155	175	120	140
	85	534.9	166.5	10.3	16.5	108.00	140	155	115	130
	75	529.1	165.9	9.7	13.6	95.20	160	175	130	145
457 × 191	66	524.7	165.1	8.9	11.4	83.70	180	200	145	165
	161	492.0	199.4	18.0	32.0	206.00	75	85	60	65
	133	480.6	196.7	15.3	26.3	170.00	90	100	70	80
	106	469.2	194.0	12.6	20.6	135.00	110	125	85	100
	98	467.2	192.8	11.4	19.6	125.26	120	135	90	105
	89	463.4	191.9	10.5	17.7	113.76	130	145	100	115
	82	460.0	191.3	9.9	16.0	104.48	140	160	105	125
	74	457.0	190.4	9.0	14.5	94.63	155	175	115	135
457 × 152	67	453.4	189.9	8.5	12.7	85.51	170	190	130	150
	82	465.8	155.3	10.5	18.9	104.53	130	145	105	120
	74	462.0	154.4	9.6	17.0	94.48	145	160	115	130
	67	458.0	153.8	9.0	15.0	85.55	155	175	125	145
	60	454.6	152.9	8.1	13.3	76.23	175	195	140	160
406 × 178	52	449.8	152.4	7.6	10.9	66.64	200	220	160	180
	85	417.2	181.9	10.9	18.2	109.00	125	140	95	110
	74	412.8	179.5	9.5	16.0	94.51	140	160	105	125
	67	409.4	178.8	8.8	14.3	85.54	155	175	115	140
	60	406.4	177.9	7.9	12.8	76.52	170	195	130	155
406 × 140	54	402.6	177.7	7.7	10.9	68.95	190	215	145	170
	53	406.6	143.3	7.9	12.9	67.90	180	200	140	160
	46	403.2	142.2	6.8	11.2	58.64	205	230	160	185
	39	398.0	141.8	6.4	8.6	49.65	240	270	190	215











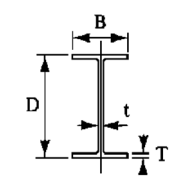

Tables are extracted from Annex D of ASFP Yellow Book - Fire Protection for structural steel in building Volume 1, 6th Edition.
The Knauf Framed Encasement System - Fire Panel and Knauf Frameless Encasement System - Fireboard is applicable to 'Box' Universal Steel Beams/Columns.

Table continued overleaf →

Specialist Knauf Encasement Systems (for both EN and BS compliance projects)

Knauf Framed Encasement System - Fire Panel and Knauf Frameless Encasement System - Fireboard

Table D.2 UK Beams (UKB) Dimensions to BS4 Part 1:2005

	Designation		Depth of section D (mm)	Width of section B (mm)	Thickness		Area of section (cm ²)	Section factor A/(Hp/A)			
	Serial size (mm)	Mass per metre (kg)			Web t (mm)	Flange T (mm)		Profile:		Box:	
								3 sides (m ⁻¹)	4 sides (m ⁻¹)	3 sides (m ⁻¹)	4 sides (m ⁻¹)
	356 × 171	67	363.4	178.1	9.1	15.7	85.49	140	160	105	125
		57	358.0	172.2	8.1	13.0	72.55	165	190	120	145
		51	355.0	171.5	7.4	11.5	64.91	185	210	135	160
		45	351.4	171.1	7.0	9.7	57.33	205	235	150	180
	356 × 127	39	353.4	126.0	6.6	10.7	49.77	210	235	165	195
		33	349.0	125.4	6.0	8.5	42.13	250	280	195	225
	305 × 165	54	310.4	166.9	7.9	13.7	68.77	160	185	115	140
		46	306.6	165.7	6.7	11.8	58.75	185	210	135	160
		40	303.4	165.0	6.0	10.2	51.32	210	240	150	185
	305 × 127	48	311.0	125.3	9.0	14.0	61.23	160	180	120	145
		42	307.2	124.3	8.0	12.1	53.40	180	200	140	160
		37	304.4	123.4	7.1	10.7	47.18	200	225	155	180
	305 × 102	33	312.7	102.4	6.6	10.8	41.83	215	240	175	200
		28	308.7	101.8	6.0	8.8	35.88	250	280	200	230
		25	305.1	101.6	5.8	7.0	31.60	280	315	225	255
	254 × 146	43	259.6	147.3	7.2	12.7	54.77	170	195	120	150
		37	256.0	146.4	6.3	10.9	47.16	195	225	140	170
		31	251.4	146.1	6.0	8.6	39.68	230	270	165	200
	254 × 102	28	260.4	102.2	6.3	10.0	36.08	220	250	175	200
		25	257.2	101.9	6.0	8.4	32.04	250	280	190	225
		22	254.0	101.6	5.7	6.8	28.02	280	320	220	255
	203 × 133	30	206.8	133.9	6.4	9.6	38.21	205	240	145	180
		25	203.2	133.2	5.7	7.8	31.97	245	285	170	210
	203 × 102	23	203.2	101.8	5.4	9.3	29.40	235	270	175	205
	178 × 102	19	177.8	101.2	4.8	7.9	24.26	260	305	190	230
	152 × 89	16	152.4	88.7	4.5	7.7	20.32	270	315	195	235
	127 × 76	13	127.0	76.0	4.0	7.6	16.52	280	325	200	245

Tables are extracted from Annex D of ASFP Yellow Book - Fire Protection for structural steel in building Volume 1, 6th Edition.

The Knauf Framed Encasement System - Fire Panel and Knauf Frameless Encasement System - Fireboard is applicable to 'Box' Universal Steel Beams/Columns.

Knauf Framed Encasement System - Fire Panel and Knauf Frameless Encasement System - Fireboard

Table D.3 UK Columns (UKC) Dimensions to BS4 Part 1:2005

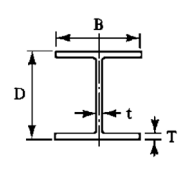

Designation	Depth of section D (mm)		Width of section B (mm)	Thickness		Area of section (cm ²)	Section factor A _v /(H _p /A)			
	Serial size (mm)	Mass per metre (kg)		Web t (mm)	Flange T (mm)		Profile:		Box:	
							3 sides (m ⁻¹)	4 sides (m ⁻¹)	3 sides (m ⁻¹)	4 sides (m ⁻¹)
356 x 406	1086	569.5	454.4	78.0	125	1387	15	20	10	15
	990	549.7	448.3	71.9	115	1263	20	20	10	15
	900	531.4	442.3	65.9	106	1150	20	25	15	15
	818	514.1	436.9	60.5	97	1044	20	25	15	20
	744	497.8	432.1	55.6	88.9	948	25	25	15	20
	677	483.1	427.8	51.2	81.5	863	25	30	15	20
	634	474.6	424.0	47.6	77.0	807.548	25	30	15	20
	551	455.6	418.5	42.1	67.5	701.930	30	35	20	25
	467	436.6	412.2	35.8	58.0	594.909	35	40	20	30
	393	419.0	407.0	30.6	49.2	500.574	40	50	25	35
	340	406.4	403.0	26.6	42.9	433.036	45	55	30	35
	287	393.6	399.0	22.6	36.5	365.708	50	65	30	45
	235	381.0	394.8	18.4	30.2	299.432	65	75	40	50
	356 x 368	202	374.6	374.7	16.5	27.0	257.219	70	85	45
177		368.2	372.6	14.4	23.8	225.506	80	95	50	65
153		362.0	370.5	12.3	20.7	194.803	90	110	55	75
129		355.6	368.6	10.4	17.5	164.335	110	130	65	90
305 x 305	283	365.3	322.2	26.8	44.1	360.426	45	55	30	40
	240	352.5	318.4	23.0	37.7	305.789	50	60	35	45
	198	339.9	314.5	19.1	31.4	252.414	60	75	40	50
	158	327.1	311.2	15.8	25.0	201.364	75	90	50	65
	137	320.5	309.2	13.8	21.7	174.415	85	105	55	70
	118	314.5	307.4	12.0	18.7	150.202	100	120	60	85
	97	307.9	305.3	9.9	15.4	123.448	120	145	75	100
254 x 254	167	289.1	265.2	19.2	31.7	212.855	60	75	40	50
	132	276.3	261.3	15.3	25.3	168.134	75	90	50	65
	107	266.7	258.8	12.8	20.5	136.381	95	110	60	75
	89	260.3	256.3	10.3	17.3	113.311	110	135	70	90
	73	254.1	254.6	8.6	14.2	93.100	130	160	80	110

Specialist Knauf Encasement Systems (for both EN and BS compliance projects)

Table continued overleaf →

Tables are extracted from Annex D of ASFP Yellow Book - Fire Protection for structural steel in building Volume 1, 6th Edition.
The Knauf Framed Encasement System - Fire Panel and Knauf Frameless Encasement System - Fireboard is applicable to 'Box' Universal Steel Beams/Columns.

Knauf Framed Encasement System - Fire Panel and Knauf Frameless Encasement System - Fireboard

Table D.3 UK Columns (UKC) Dimensions to BS4 Part 1:2005

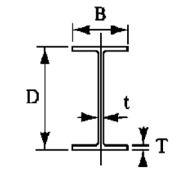

Designation		Depth of section D (mm)	Width of section B (mm)	Thickness		Area of section (cm ²)	Section factor A/V(Hp/A)			
Serial size (mm)	Mass per metre (kg)			Web t (mm)	Flange T (mm)		Profile:		Box:	
		3 sides (m ⁻¹)	4 sides (m ⁻¹)			3 sides (m ⁻¹)	4 sides (m ⁻¹)			
203 x 203	127	241.4	213.9	18.1	30.1	162.00	65	80	45	55
	113	235.0	212.1	16.3	26.9	145.00	75	90	45	60
	100	228.6	210.3	14.5	23.7	127.00	80	100	55	70
	86	222.2	209.1	12.7	20.5	109.636	95	115	60	80
	71	215.8	206.4	10.0	17.3	90.427	110	135	70	95
	60	209.6	205.8	9.4	14.2	76.373	130	160	80	110
	52	206.2	204.3	7.9	12.5	66.282	150	180	95	125
	46	203.2	203.6	7.2	11.0	58.731	170	200	105	140
152 x 152	51	170.2	157.4	11.0	15.7	65.20	120	145	75	100
	44	166.0	155.9	9.5	13.6	56.10	135	165	85	115
	37	161.8	154.4	8.0	11.5	47.112	160	195	100	135
	30	157.6	152.9	6.5	9.4	38.263	195	235	120	160
	23	152.4	152.2	5.8	6.8	29.245	250	305	155	210

DEFLECTION HEADS

Our systems

- Performer Systems
- Performer Systems - Resilient Bar
- Performer Systems - Resilient Bar & Aquapanel® Indoor
- Isolator Systems
- Shaftwall Systems
- Shaftwall and Smokeshaft Systems
- Independent 'I' Stud Systems

Knauf Deflection Heads

Deflection heads are a form of construction detail which are located at the top of drywall metal partitions, linings and shaftwall systems. They are required to accommodate the movement at the interface with the superstructure from any live and or dead loads. Such movement, known as deflection, can occur upward, downward or in both directions. By determining the magnitude and direction of deflection, typically provided by the project engineers - drywall metal partitions, linings and shaftwall systems can be appropriately designed to accommodate such movement without causing compression, crushing, or compromising the system's performance.

Extract, figure 2, from BS8000-8:2023 Workmanship on construction sites Part 8: Design and installation of drylining systems – code of practise helps summarise typical head details to accommodate various deflections of upward and downward.

Knauf have a set of deflection head details to accommodate various deflection allowances which have been designed to maintain specific fire resistance periods, such details can be found in this section.

Please refer to Knauf deflection head details can accommodate a maximum downward (-) deflection of 25mm and 50mm. Such maximum allowances can also support the following deflection variations. Table A summarises the various combinations of deflection allowances when adopting either the downward -25mm and -50mm deflection head detail.

Figure 2: Typical head details of partitions to accommodate vertical deflection of the structural element

BS8000-8:2023 Workmanship on construction sites Part 8: Design and installation of drylining systems – code of practise.

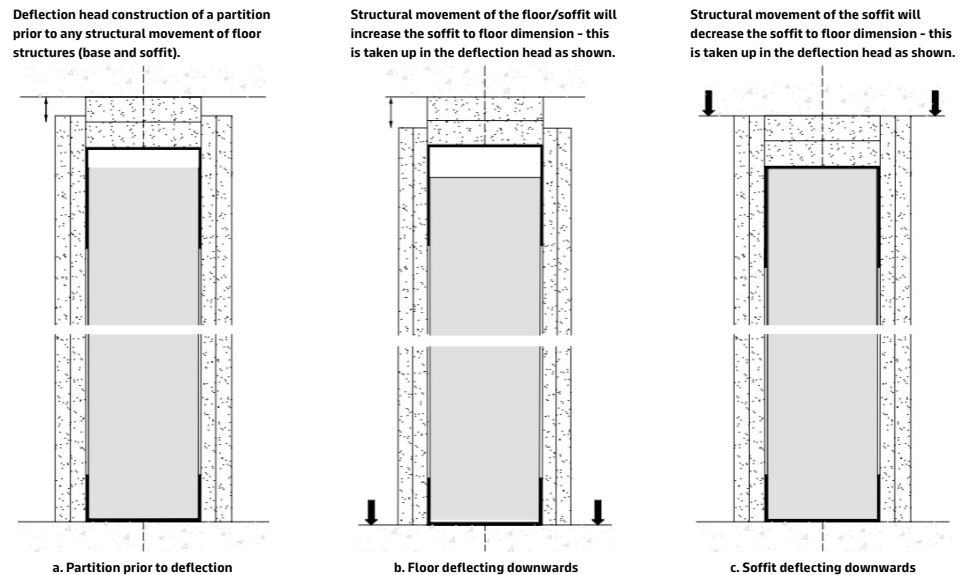

Table A: Deflection head allowance summary

Deflection allowances (mm)	
Details for -25 (downward)	Details for -50 (downward)
+/- 12.5	+/- 25
+10 / -15	+30 / -20
+15 / -10	+20 / -30
	+40 / -10
	+10 / -40

Knauf Deflection Heads - Performer Systems

Deflection Heads

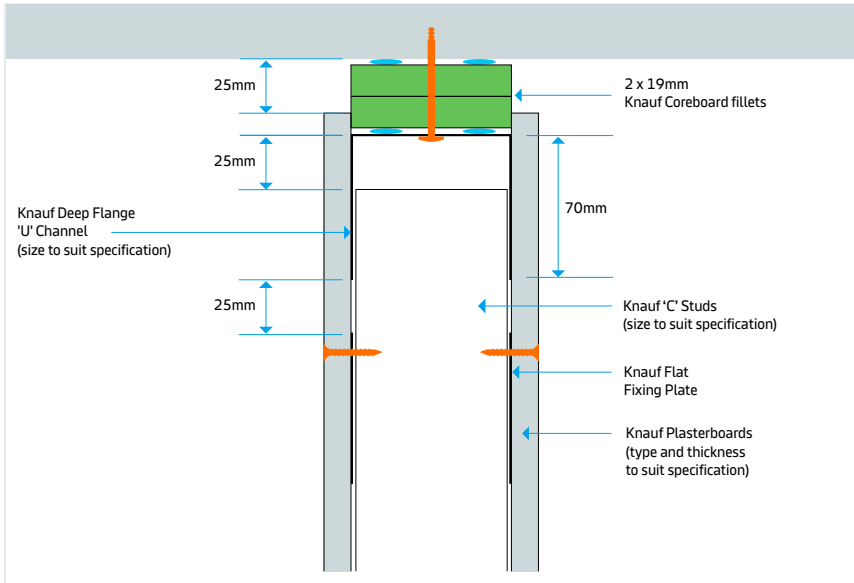

Figure 1

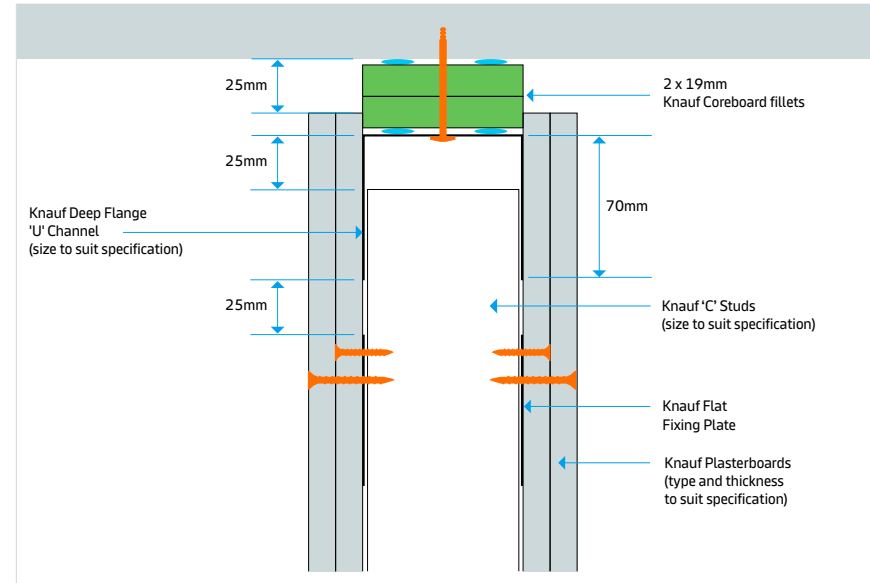

Figure 2

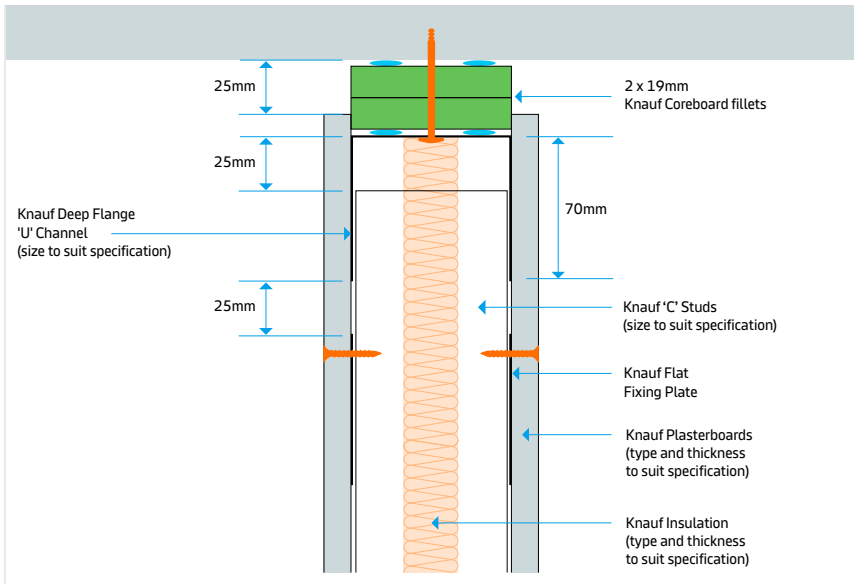

Figure 3

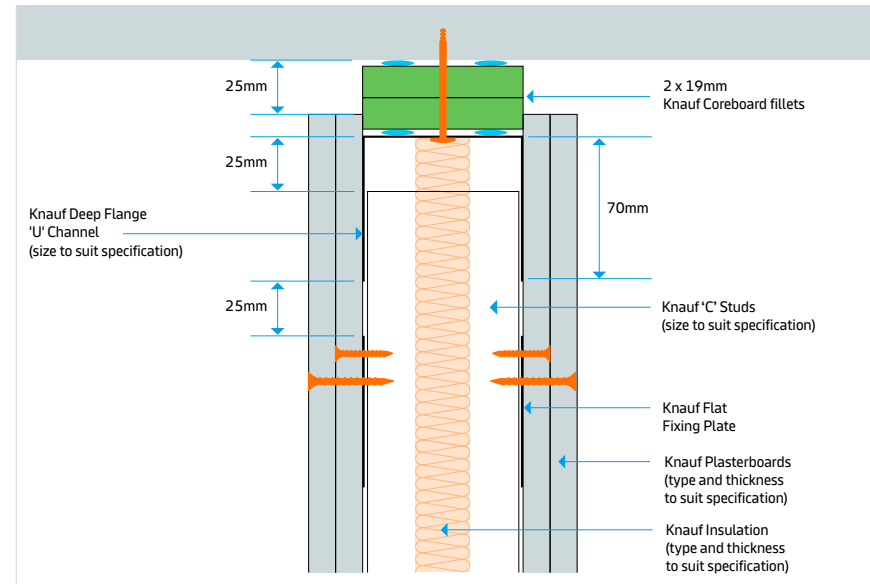

Figure 4 Detail also applies when using Knauf 'MW' Studs

Knauf Deflection Heads - Performer Systems

Deflection Heads

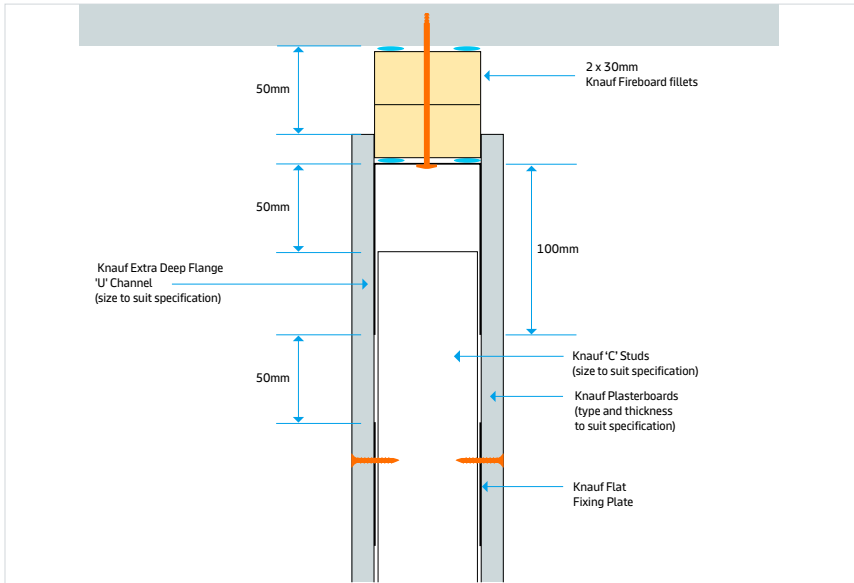

Figure 5

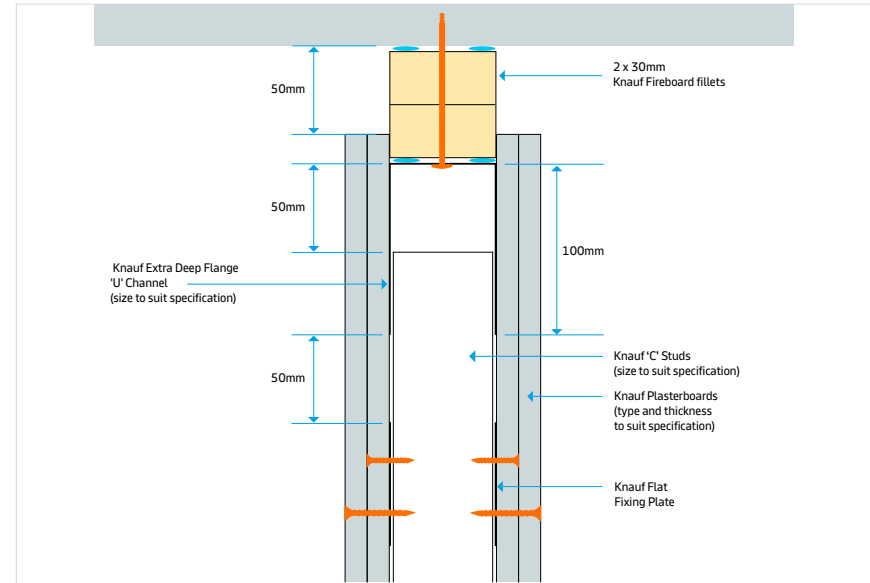

Figure 6

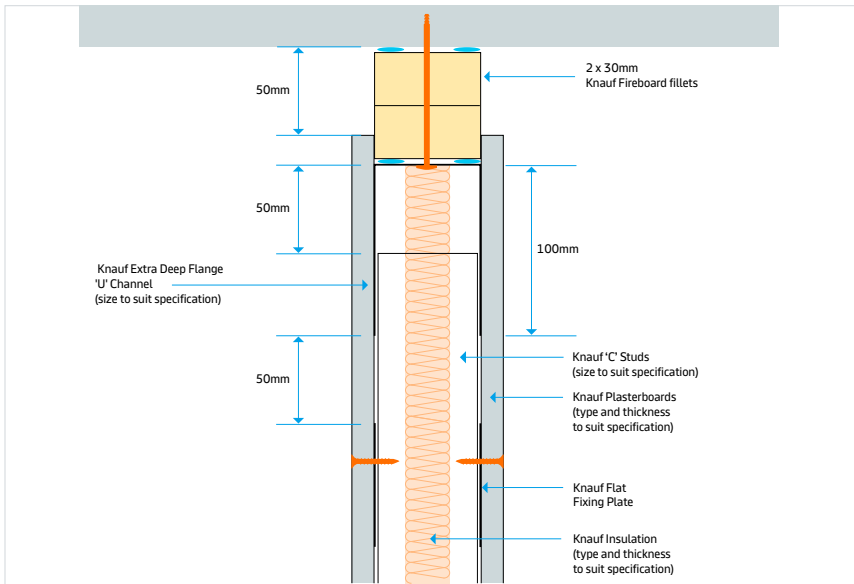

Figure 7

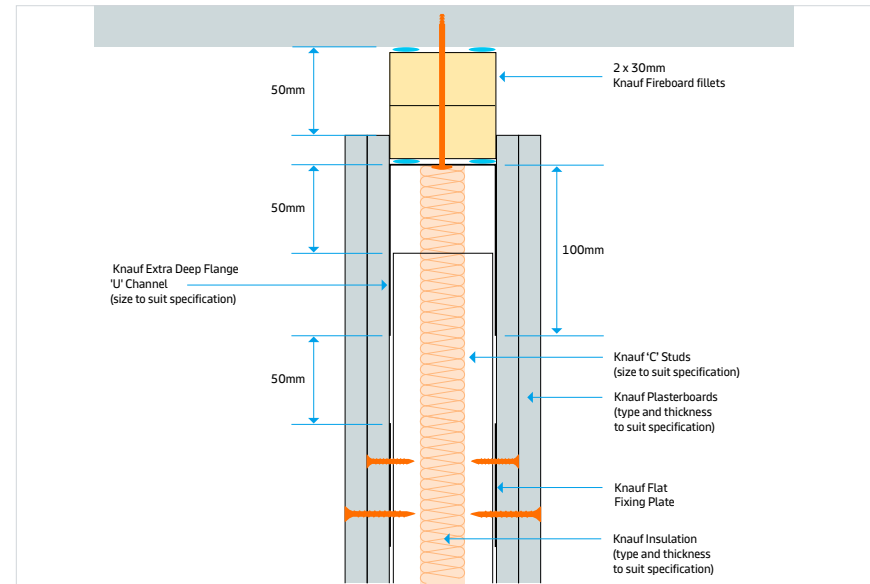

Figure 8 Detail also applies when using Knauf 'MW' Studs

Knauf Deflection Heads - Performer Systems

Deflection Heads

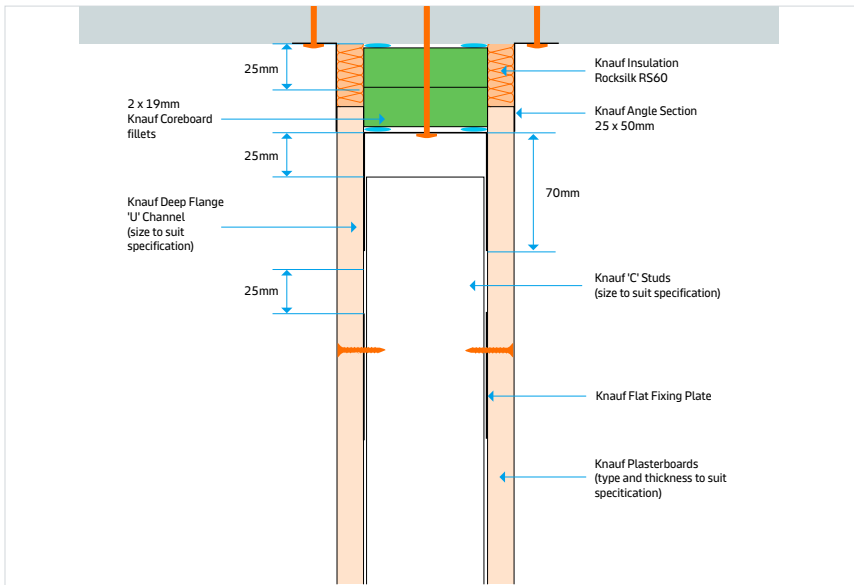

Figure 9

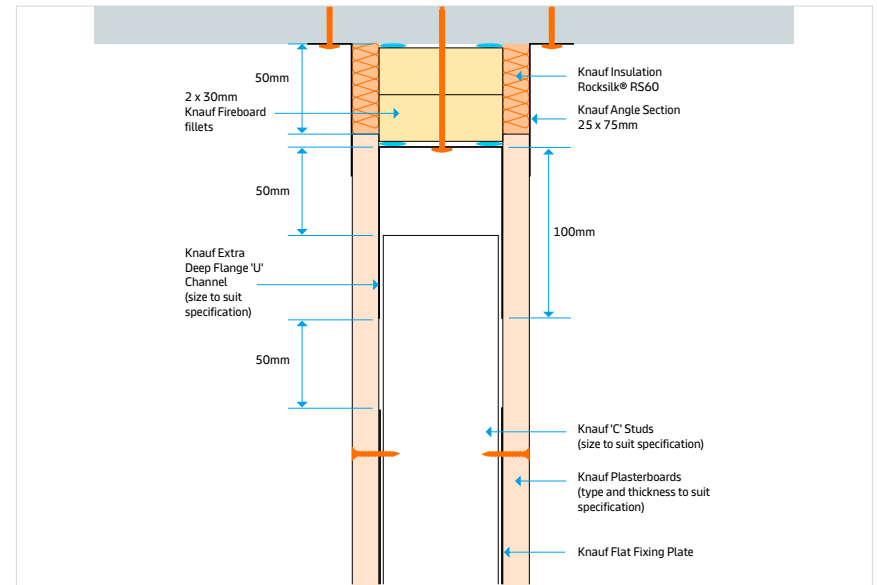

Figure 10

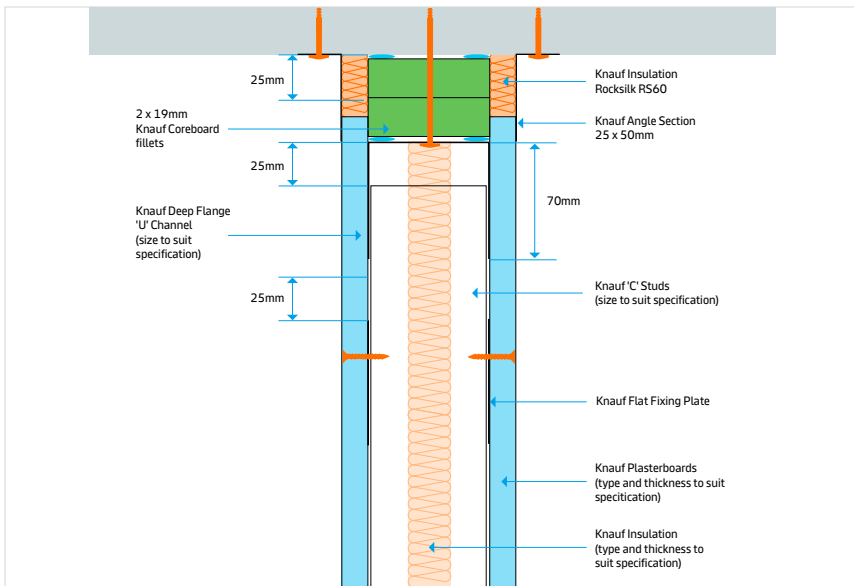

Figure 11

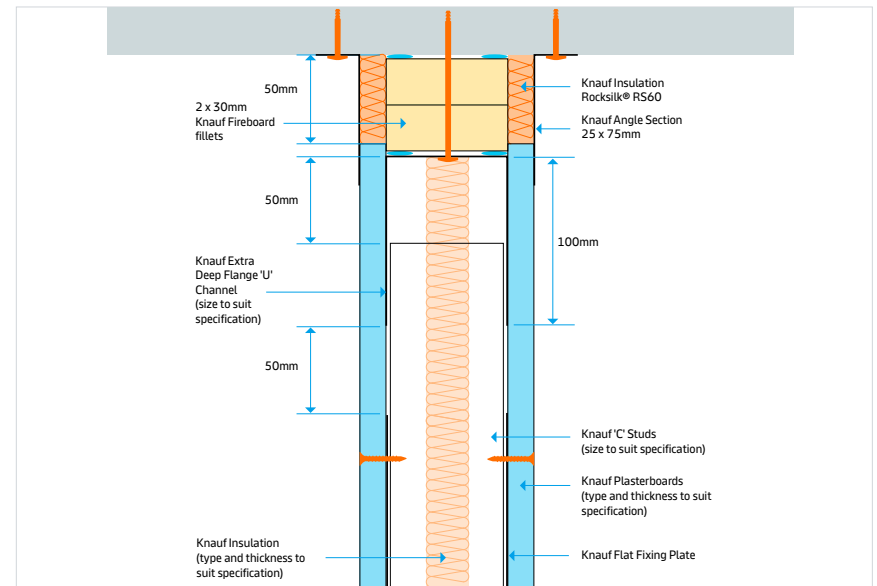

Figure 12

Knauf Deflection Heads - Performer Systems

Deflection Heads

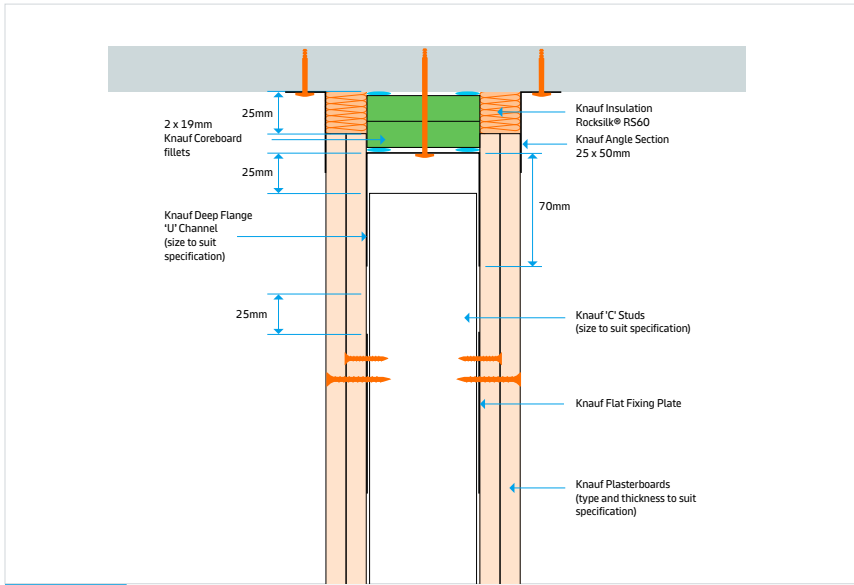

Figure 13

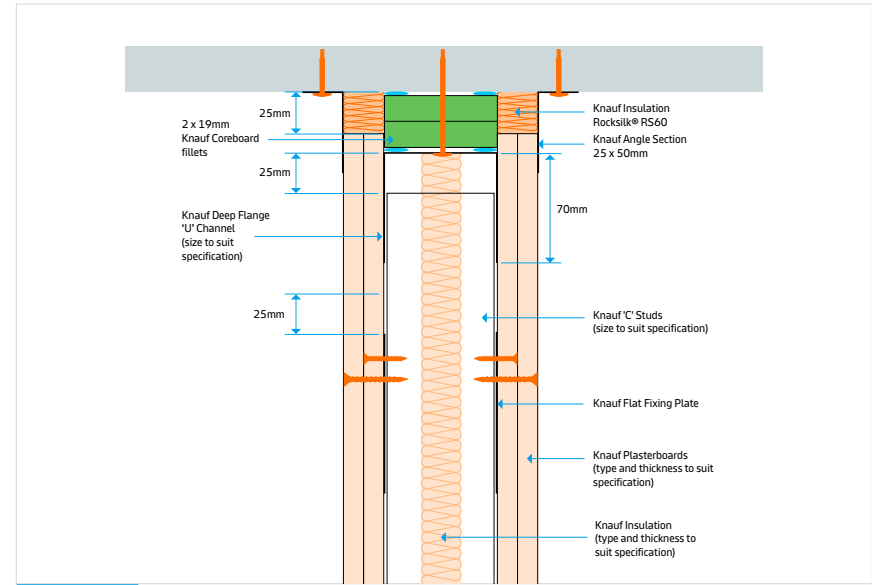

Figure 14 Detail also applies when using Knauf 'MW' Studs

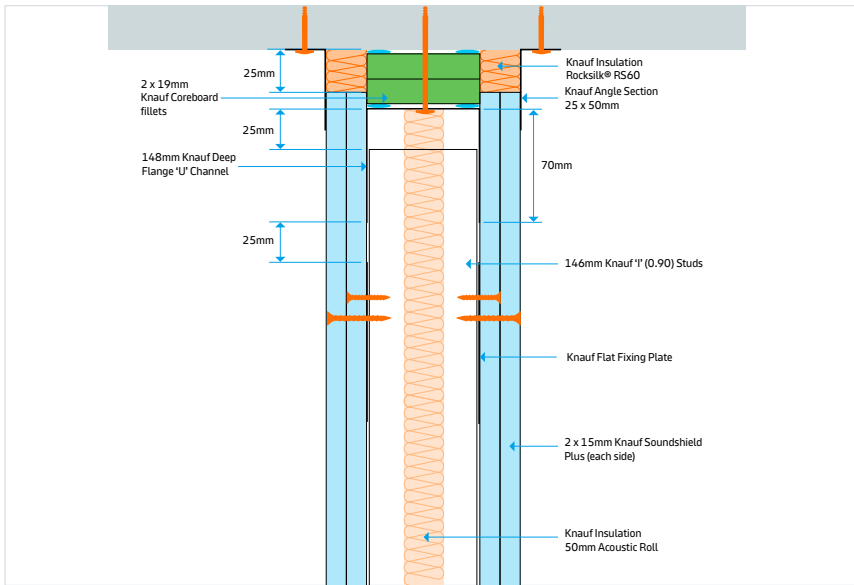

Figure 15

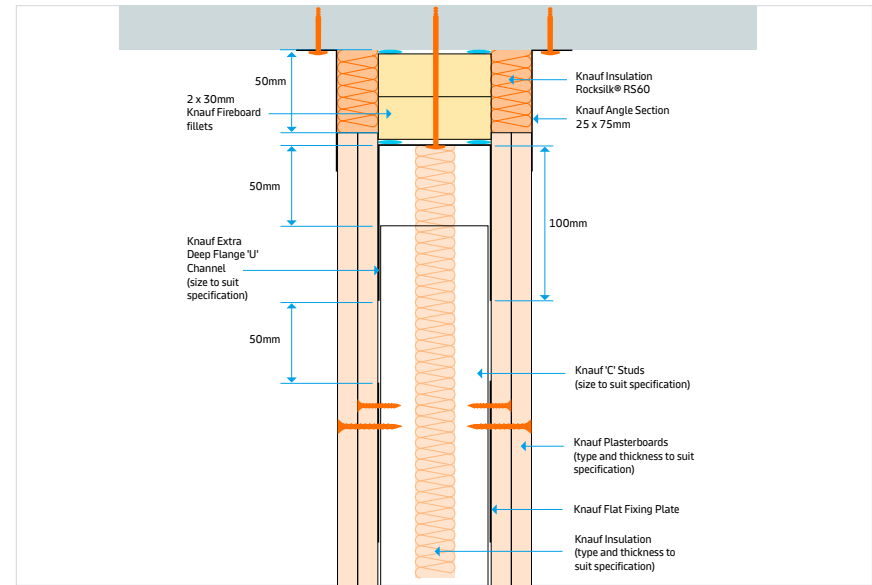

Figure 16 Detail also applies when using Knauf 'MW' Studs

Knauf Deflection Heads - Performer Systems

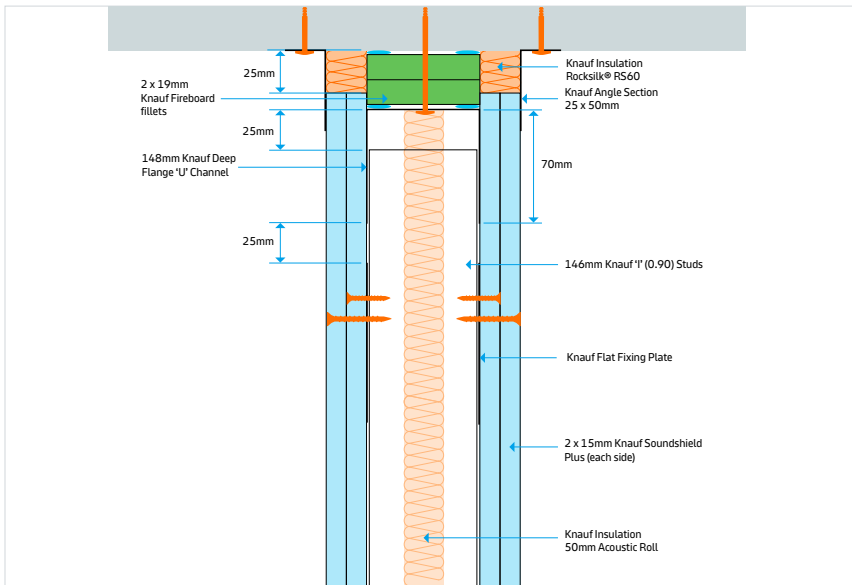

Figure 17

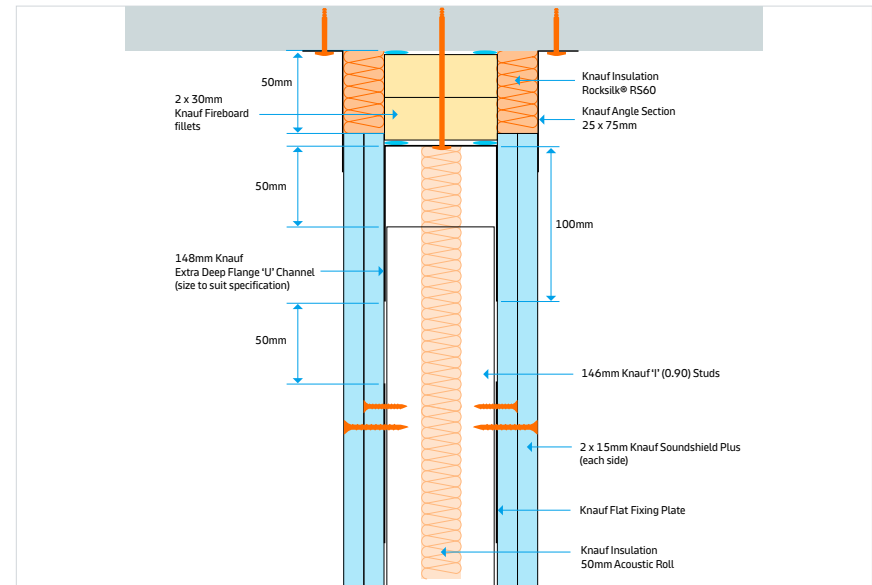

Figure 18

Deflection Heads

Knauf Deflection Heads - Performer Systems - Resilient Bar

Deflection Heads

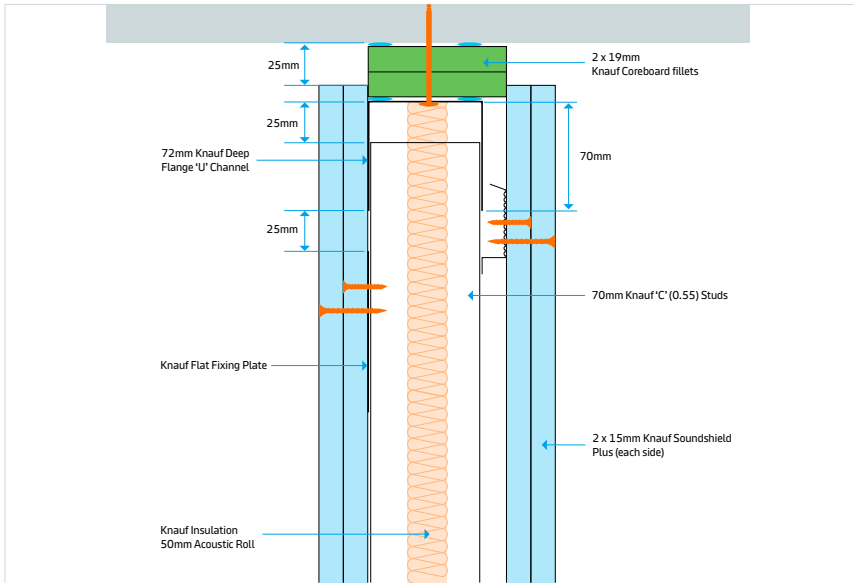

Figure 19

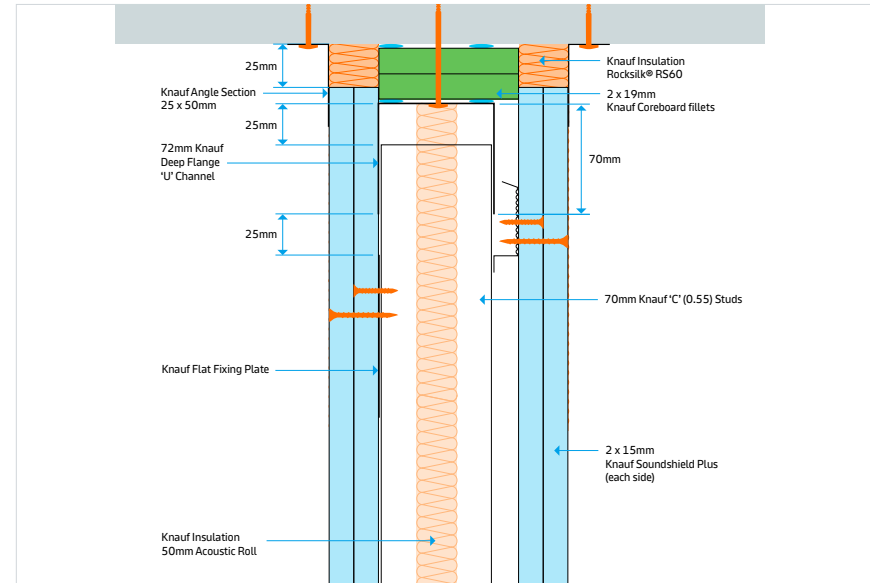

Figure 20

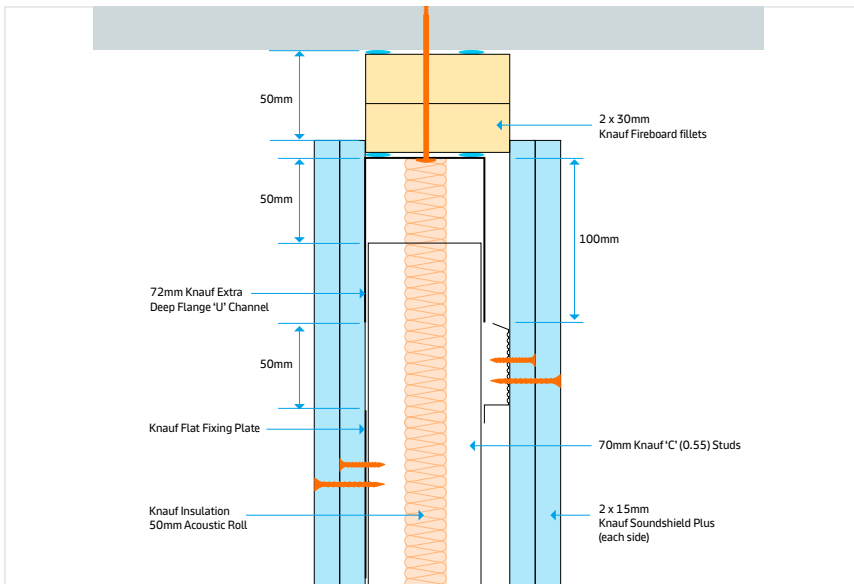

Figure 21

Knauf Deflection Heads - Performer Systems - Resilient Bar & AQUAPANEL® Indoor

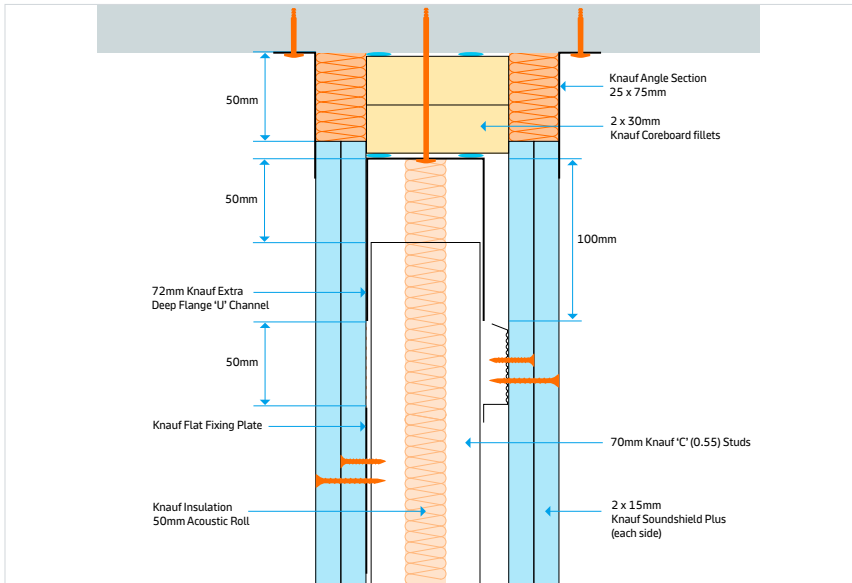

Figure 22

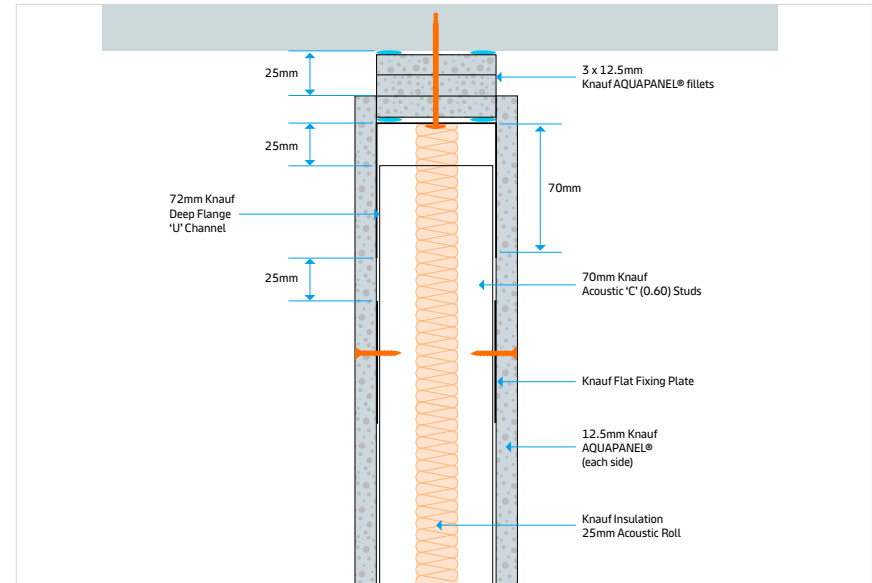

Figure 23

Deflection Heads

Knauf Deflection Heads - Isolator Systems

Deflection Heads

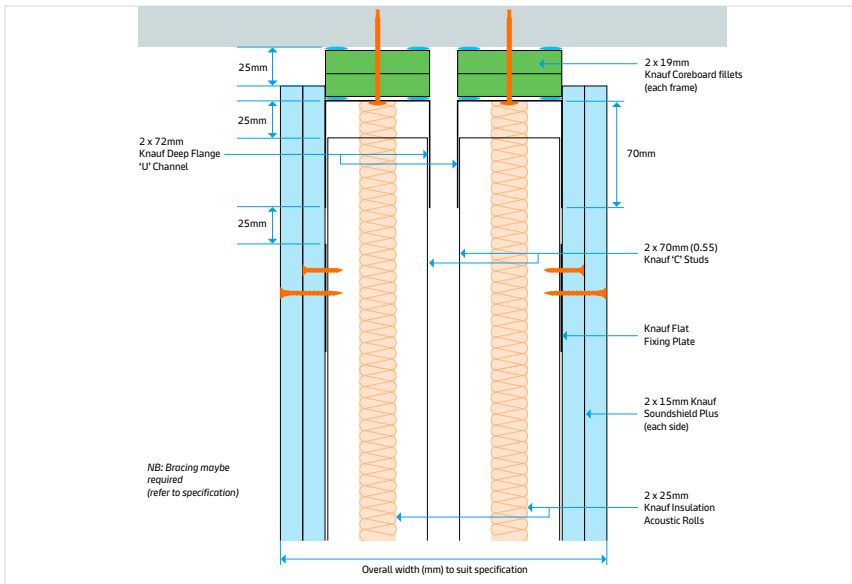

Figure 24

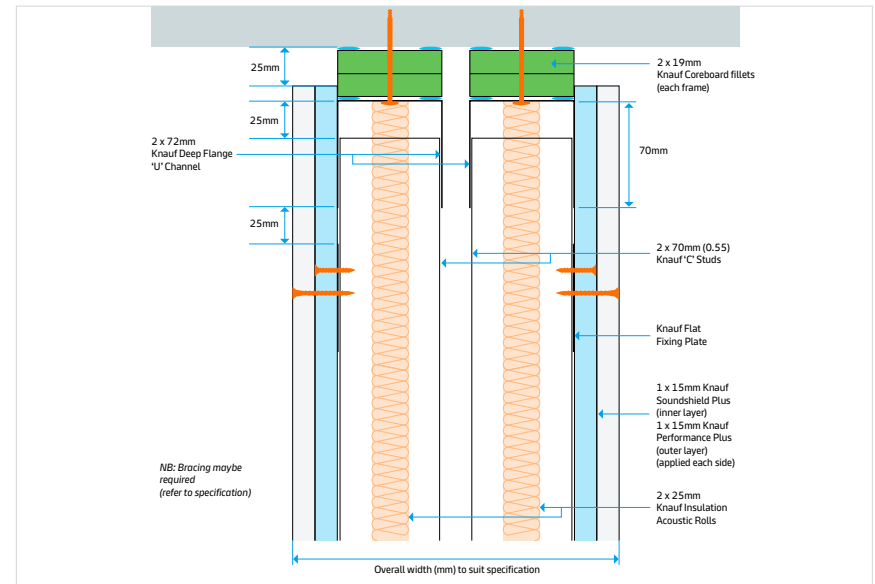

Figure 25

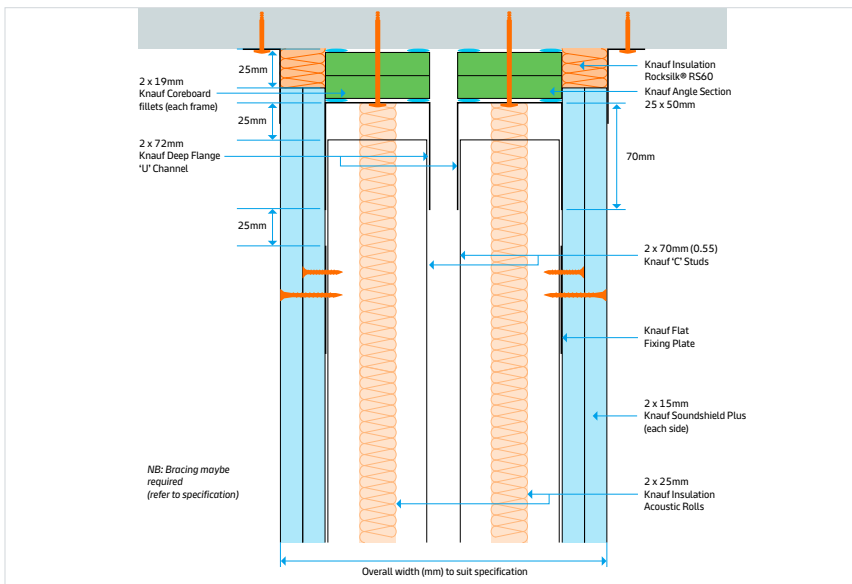

Figure 26

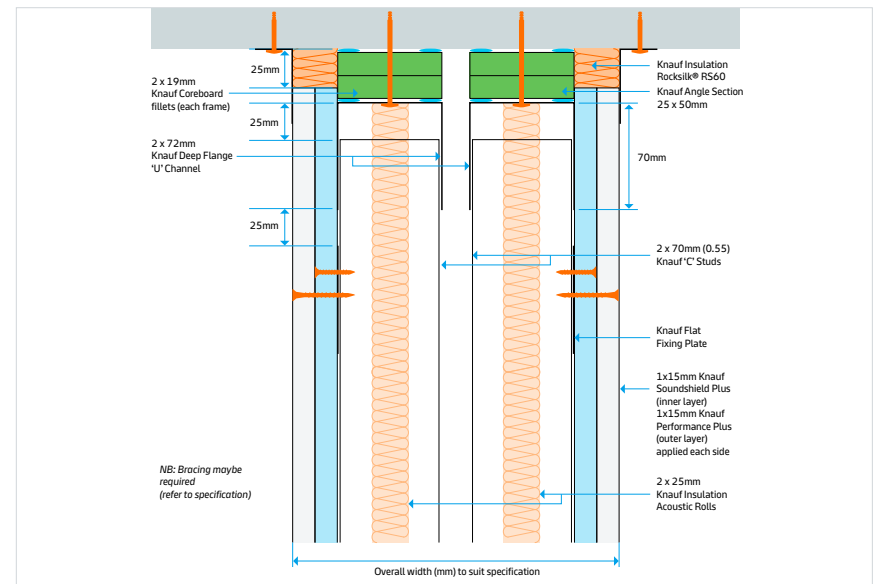

Figure 27

Knauf Deflection Heads - Isolator Systems

Deflection Heads

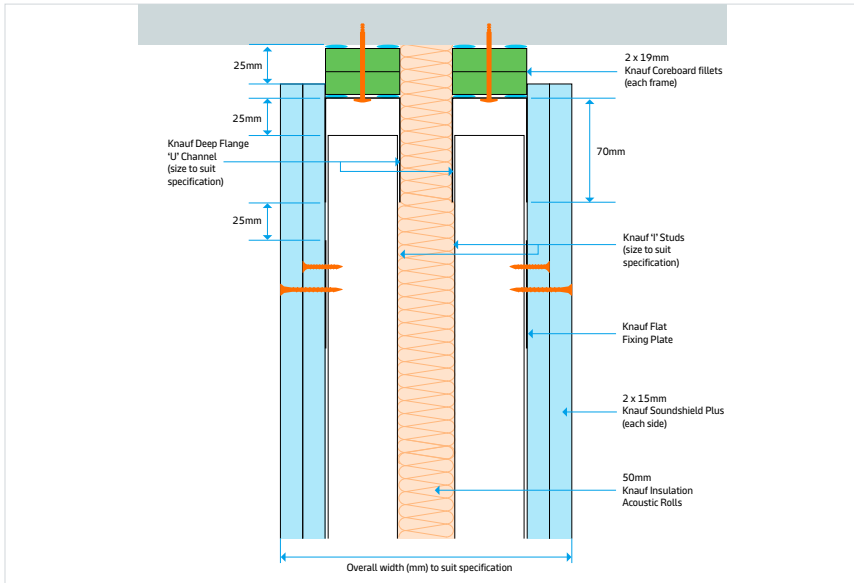

Figure 28

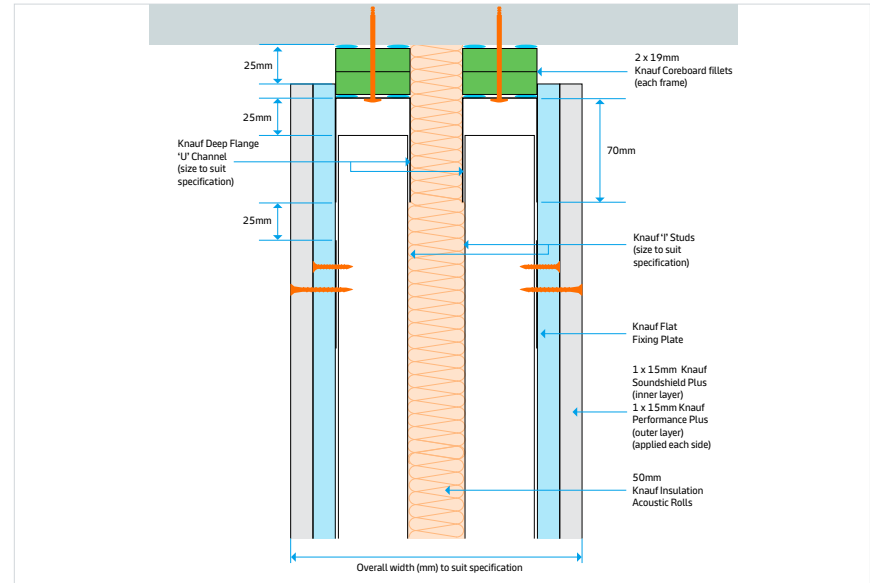

Figure 29

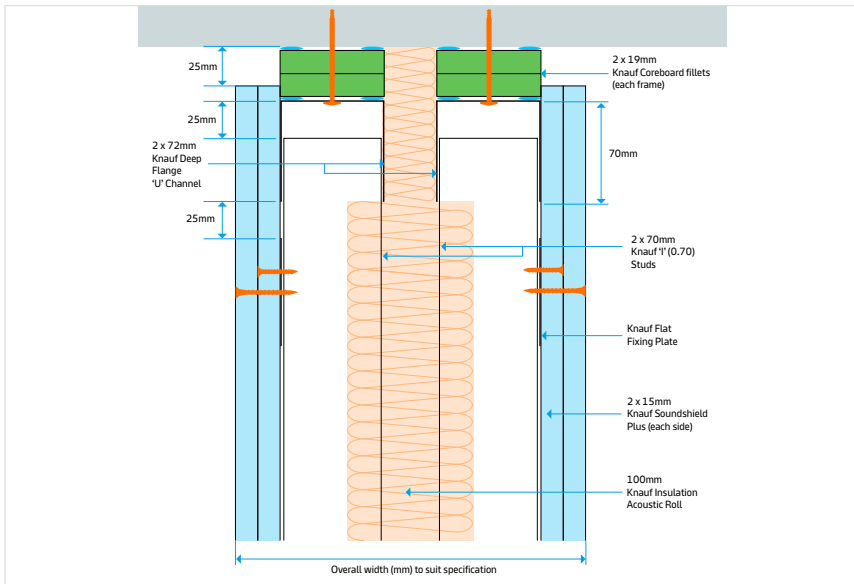

Figure 30

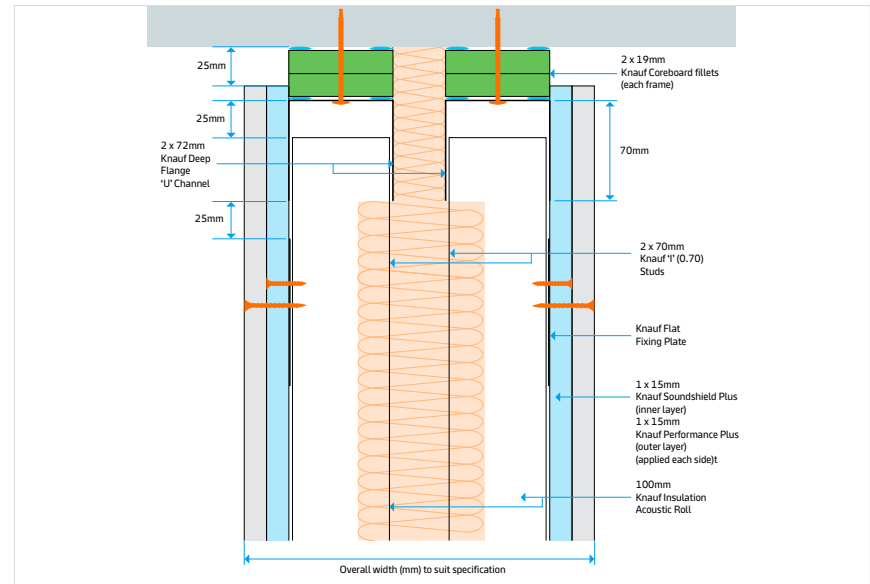

Figure 31

Knauf Deflection Heads - Isolator Systems

Deflection Heads

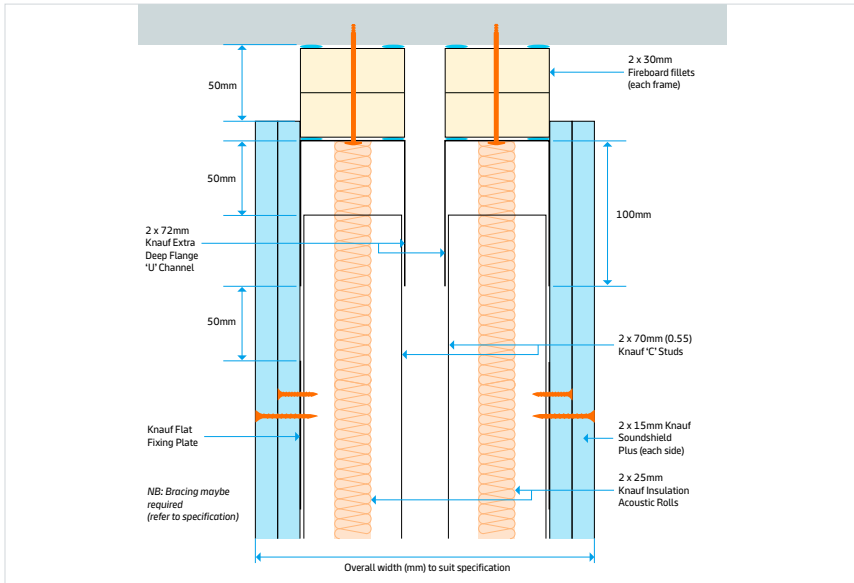

Figure 32

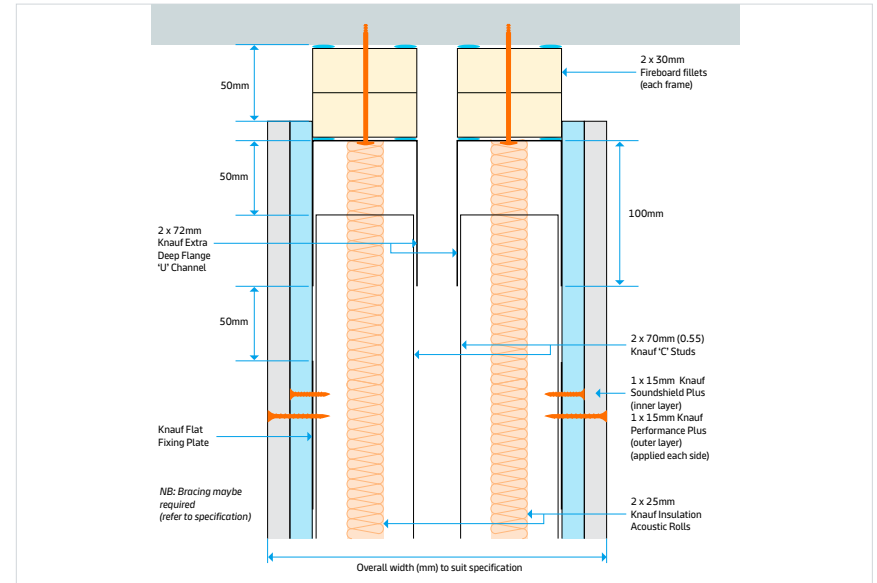

Figure 33

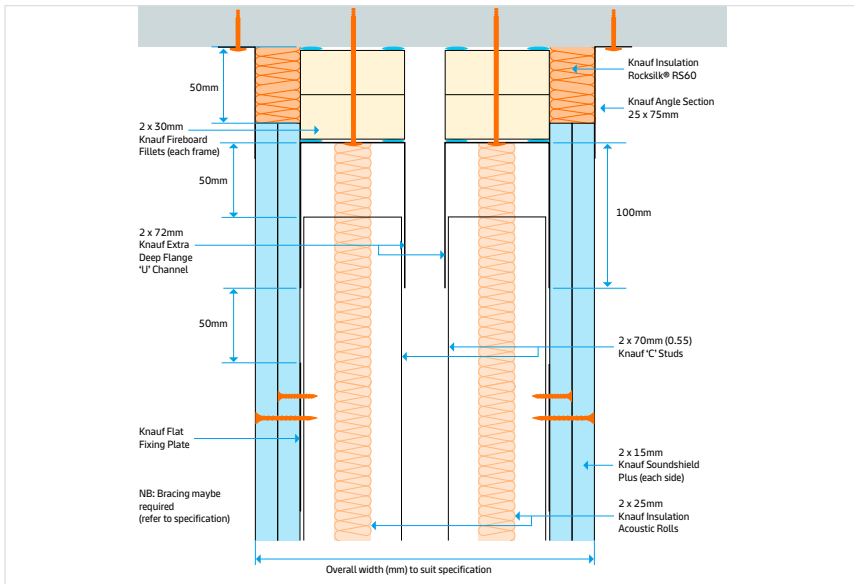

Figure 34

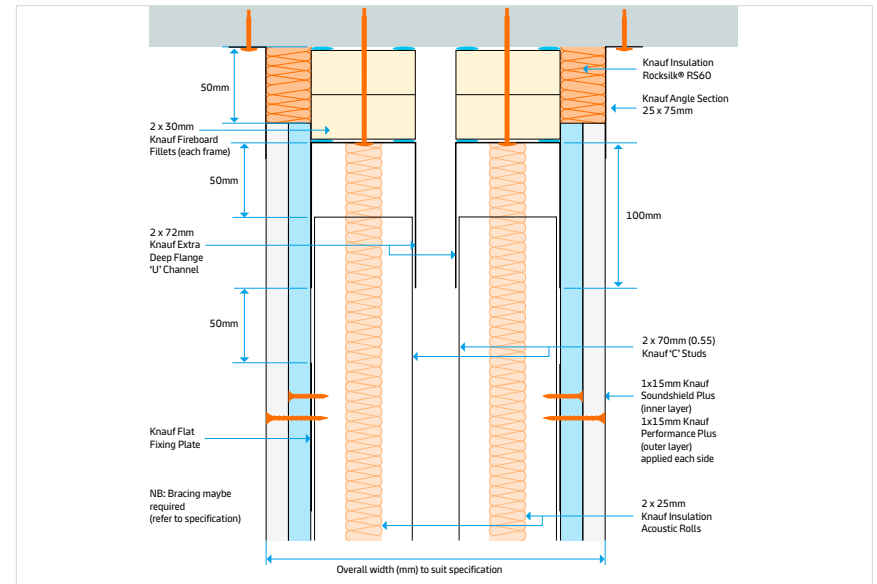

Figure 35

Knauf Deflection Heads - Isolator Systems

Deflection Heads

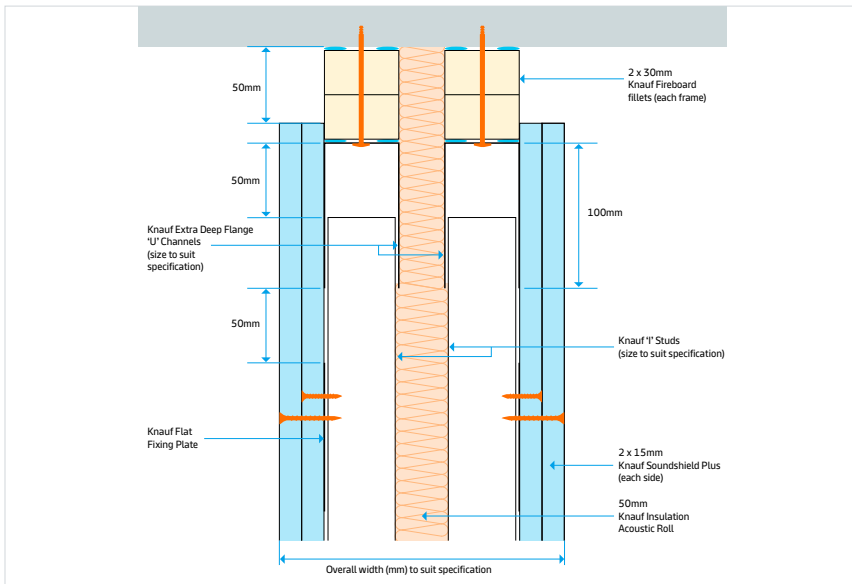

Figure 36

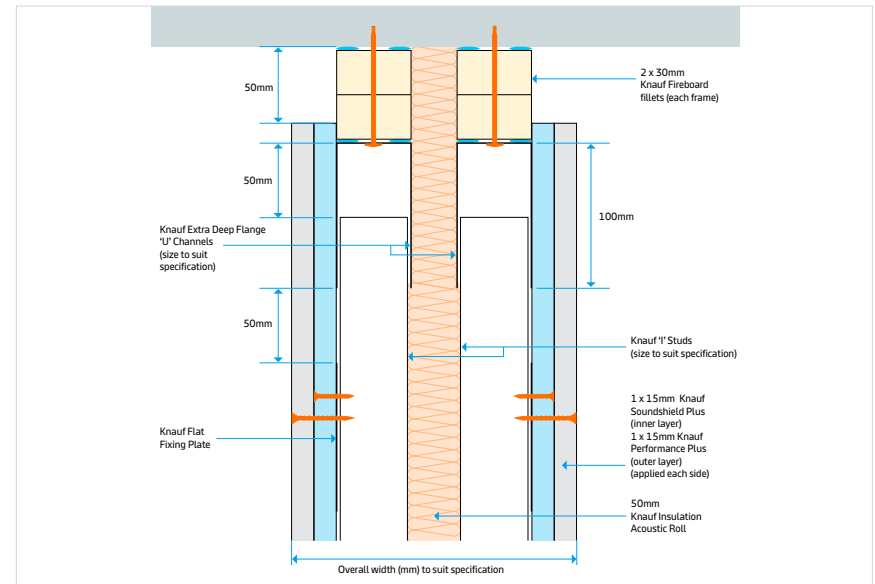

Figure 37

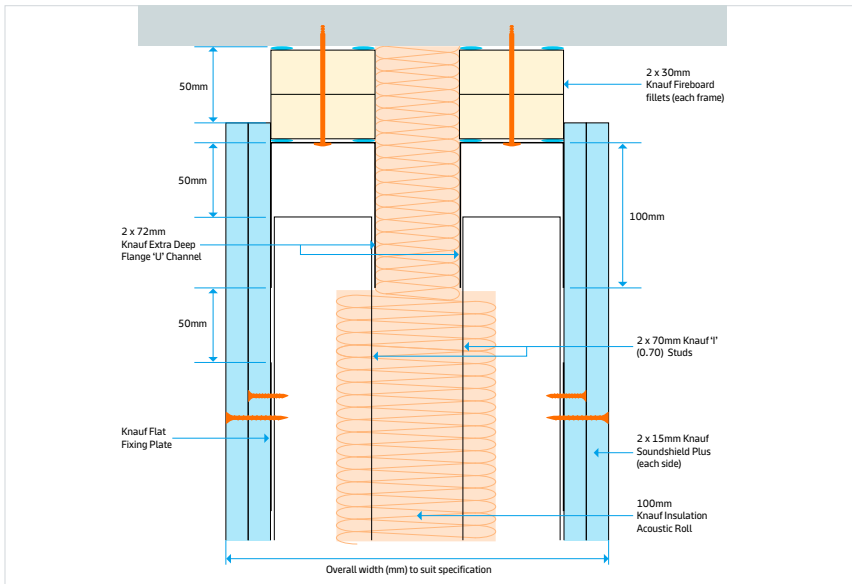

Figure 38

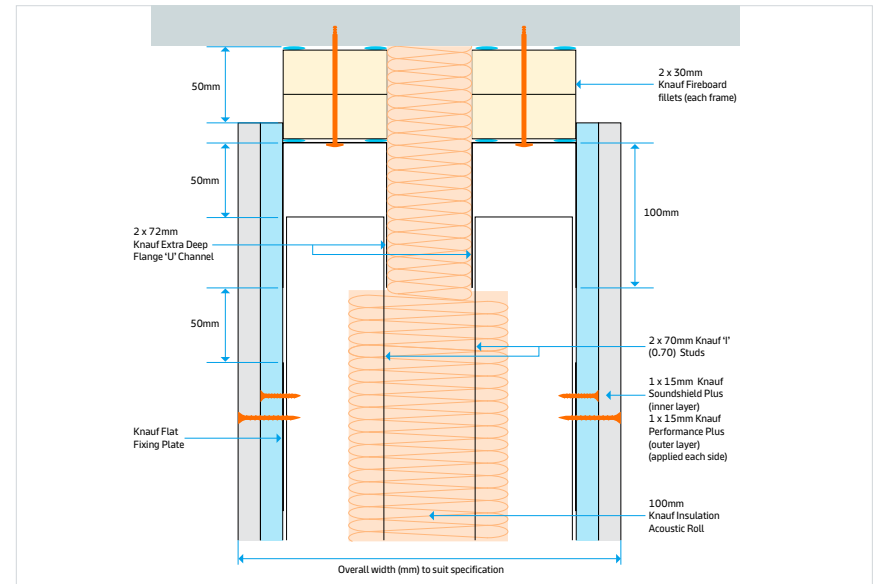

Figure 39

Knauf Deflection Heads - Shaftwall Systems

Deflection Heads

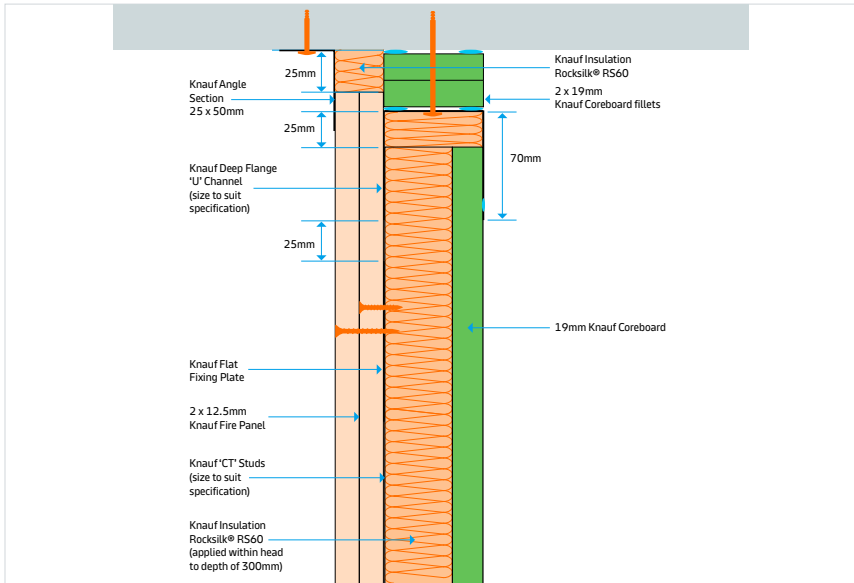

Figure 40

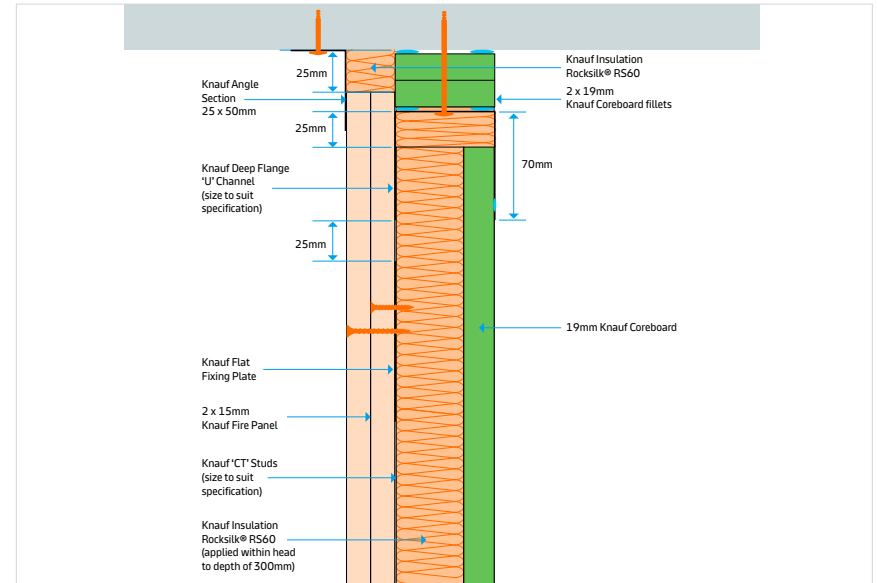

Figure 41

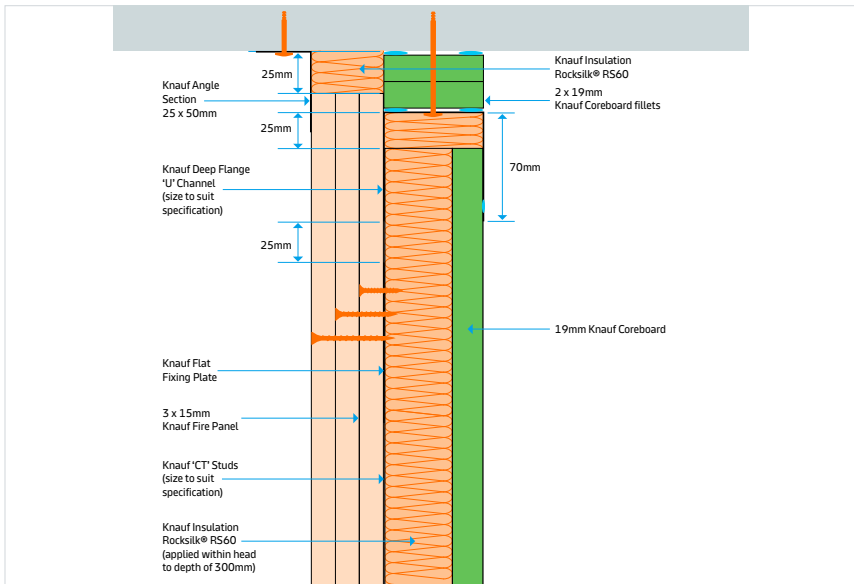

Figure 42

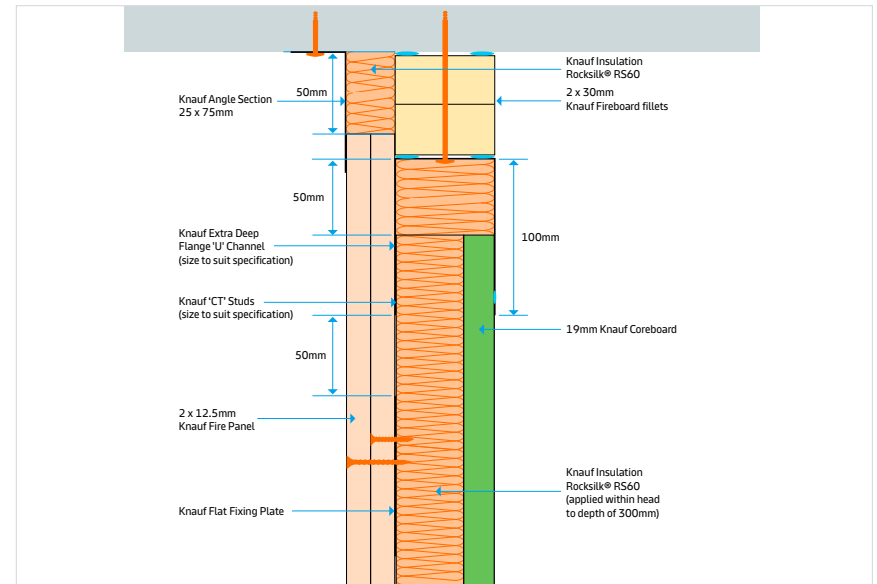

Figure 43

Knauf Deflection Heads - Shaftwall and Smokeshaft Systems

Deflection Heads

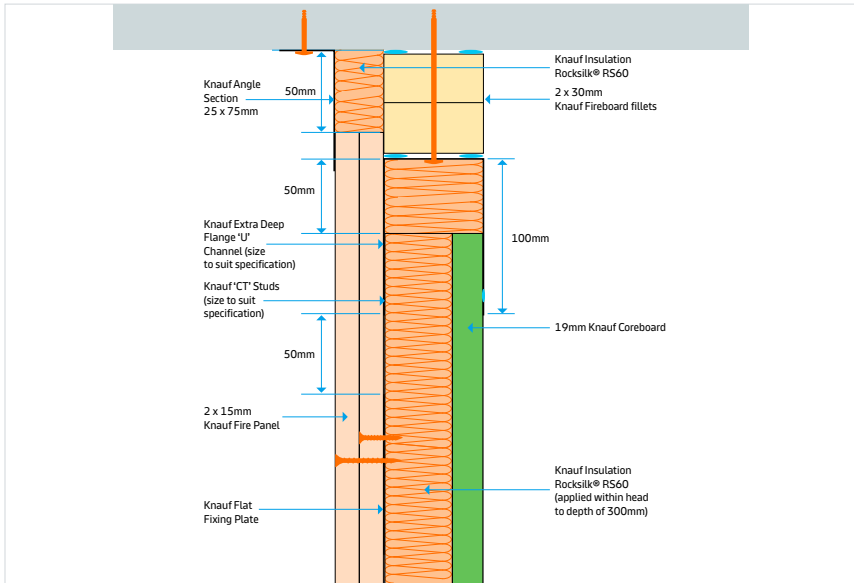

Figure 44

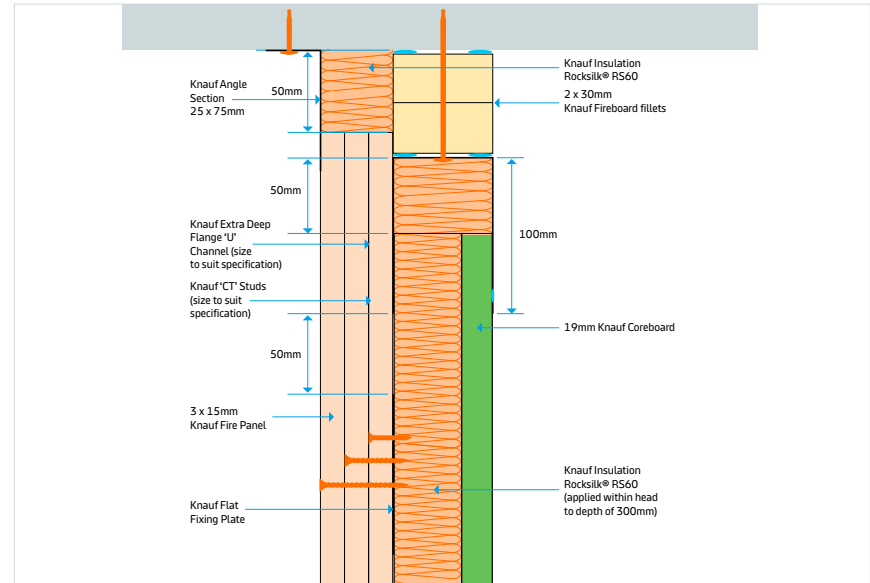

Figure 45

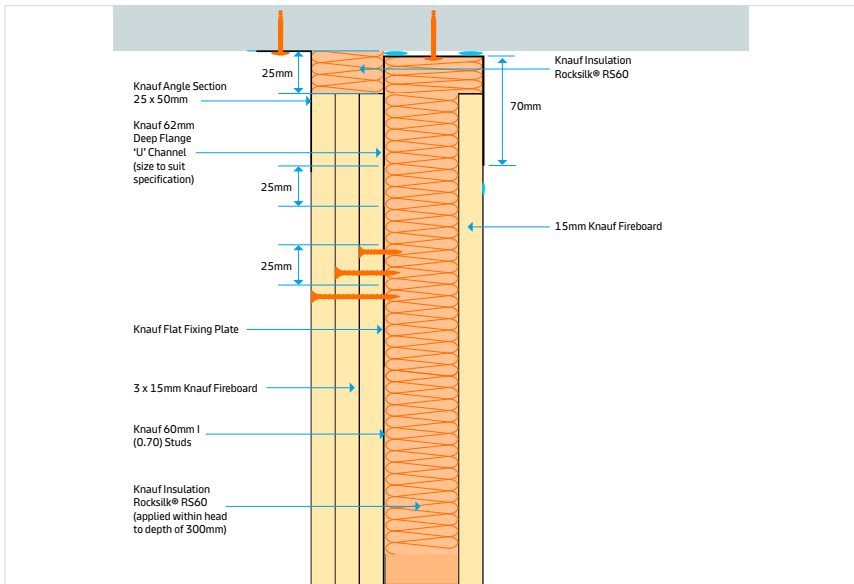

Figure 46

Knauf Deflection Heads - Independent 'I' Stud Systems

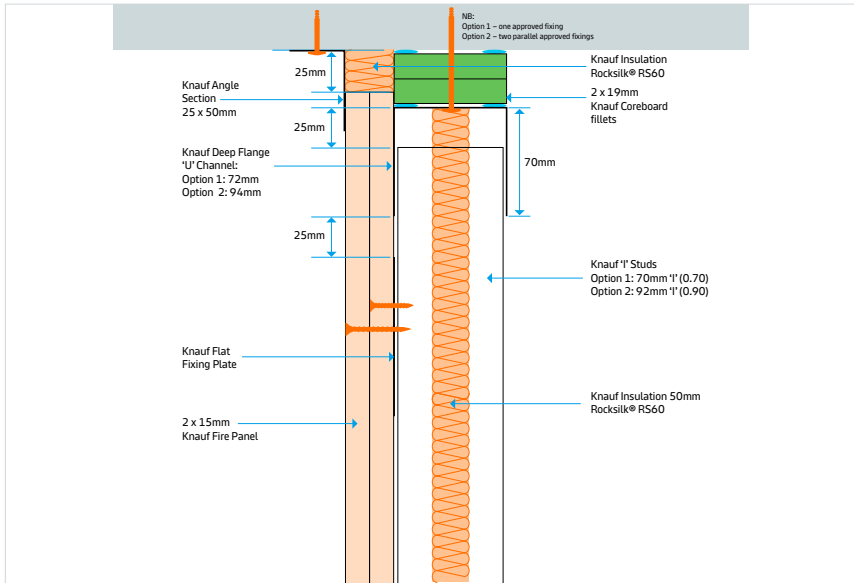

Figure 47

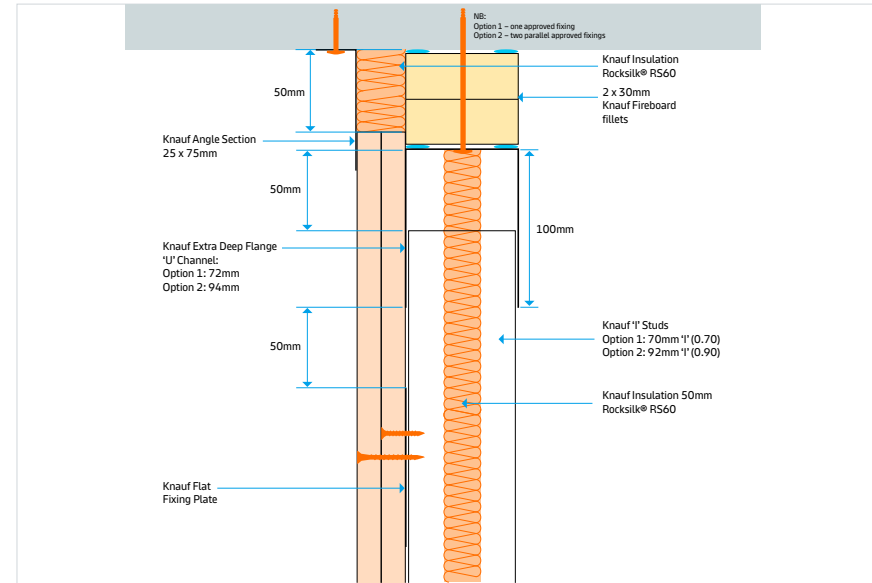

Figure 48

KNAUF

Customer Service

UK Tel: 0800 521 050
Eire Tel: 01 4620739
Email: cservice@knauf.com

Technical Service

0800 521 050 (Option 2)
technical-uk@knauf.com
(excluding Public Holidays)

Addresses

Knauf
Kemsley Fields Business Park
Sittingbourne
Kent ME9 8SR

Knauf
87 Broomhill Road
Tallaght
Dublin 24
D24 WR85

Social Media

 [KnaufUK](#)

 [KnaufUK](#)

 [Knauf UK & Ireland](#)

 [@Knauf UK](#)

Website

www.knauf.com
www.knauf.ie

Build on us.

The information given in this publication is believed to be current and accurate as at the date of publication, but no warranty, express or implied is given. Updates will not be automatically issued. © Copyright Knauf 2025