

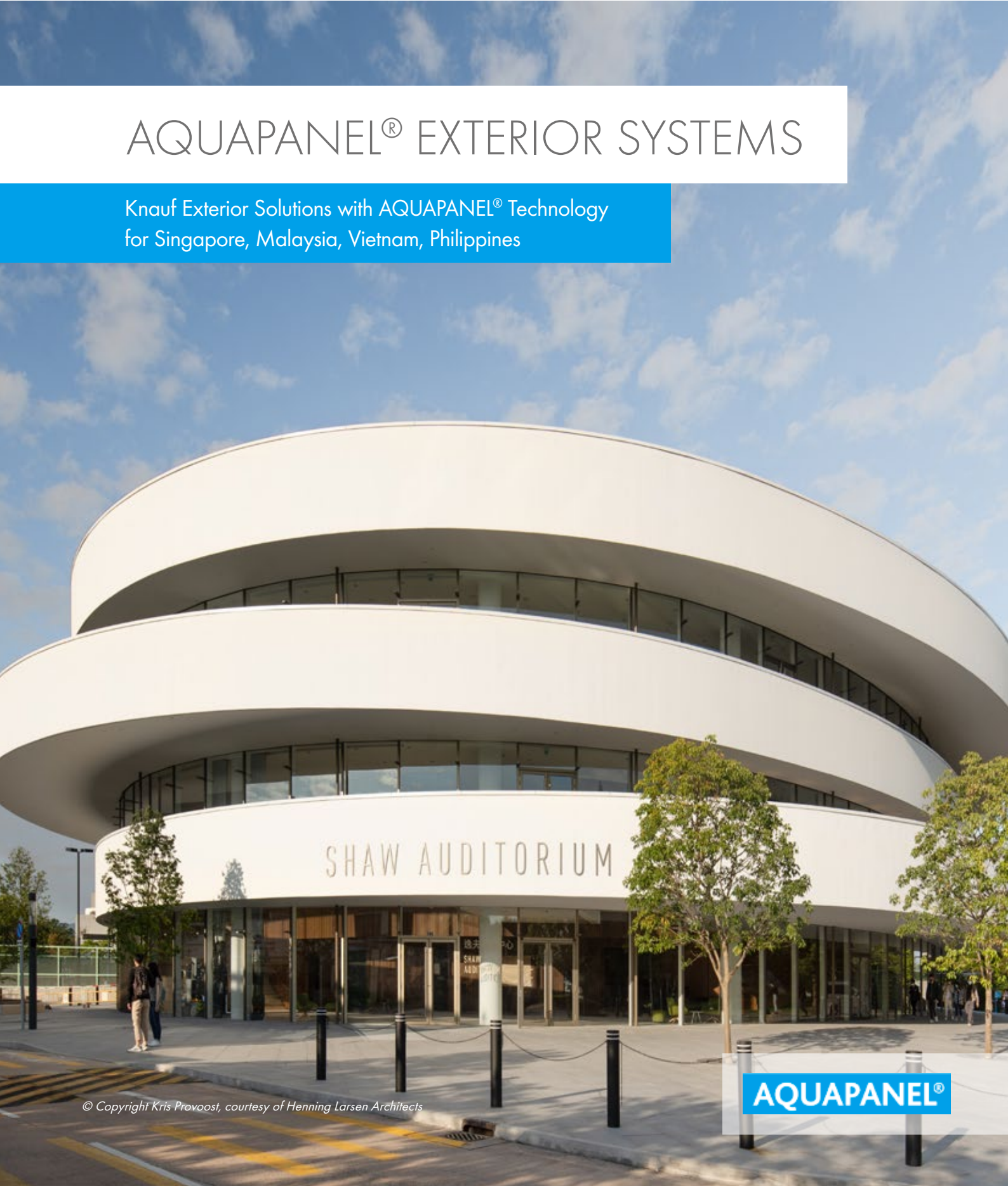

AQUAPANEL® EXTERIOR SYSTEMS

Knauf Exterior Solutions with AQUAPANEL® Technology
for Singapore, Malaysia, Vietnam, Philippines



SHAW AUDITORIUM

AQUAPANEL®

AQUAPANEL® Exterior Systems delivers creativity and certainty from seaside and hospitality projects through to commercial and residential buildings.



Markor Art Center | Beijing, China

System introduction

AQUAPANEL® Exterior Systems are high-performance, economical and sustainable solutions for drylining style construction of exterior walls, claddings and ceilings.

AQUAPANEL® Exterior Wall comes in two basic types: drywall, or as a rear-ventilated rainscreen facade. It therefore offers an extremely flexible and adaptable solution, which can accommodate an impressive range of designs, helping to turn vision into reality.

From external soffits, underpasses or open and underground car parks to exterior ceilings, our solution is engineered to withstand the most challenging wet conditions.

Outstanding protection against high humidity and moisture

The systems are the perfect solutions for exterior walls, claddings, and ceilings exposed to moisture, wind loading, and coastal environments. The components are designed and tested to achieve the highest performance in construction.

AQUAPANEL® Cement Board Outdoor is water-resistant and made of inorganic materials, which prevents mildew from forming and spreading.

The steel framing system, designed to support AQUAPANEL® Cement Board Outdoor is supplied by Rondo, with components coated with Zinc Z275/Z450, making it suitable for a variety of exterior systems (refer to Rondo for details).

Options for external finishes

Different external renders can be specified as a finish coat, offering options for texture and colors. The system can also accommodate other materials, such as tiles.

Complete Knauf engineered solution backed by industry experts.

Our team of engineers and specification managers will provide you with support throughout the project; from conceptual design, to reviewing architectural drawings and site support to ensure optimum performance in design and construction.

EXTERIOR WALL, CLADDINGS AND CEILING

Benefits

- › Simple installation
- › Easy to cut, score, and snap
- › No pre-drilling for fasteners
- › Resistant to moisture and driving rain
- › Mold and mildew-resistant
- › Dimensionally stable, robust and durable
- › Non-combustible (A1): complies with European standards
- › Creative design opportunities
 - Options for the creation of curved exterior walls, claddings and ceilings
 - Spectacular seamless surfaces, thanks to expansion joints that are only needed every 15 m to enable a 225 m² closed area without a visible joint*
- › Large choice of colours, textures, and finishes with different external render systems

With Knauf AQUAPANEL® Exterior Systems, the exterior walls, claddings and ceilings are optimally protected against various types of weather effects, regardless of their location.

*A control/movement joint must be installed if there is a control/movement joint in the structure underneath.



Eagle in Flight | Tirana, Albania

Physical properties - AQUAPANEL® Cement Board Outdoor

| | |
|---|---|
| Length (mm) | 2,400/2,440 |
| Width (mm) | 1,200/1,220 |
| Depth (mm) | 12.5 |
| Min. bending radius for 1,200 mm wide board (m) | 3 |
| Min. bending radius for 300 mm wide strip (m) | 1 |
| Weight (kg/m ²) | approx. 16 |
| Dry bulk density (kg/m ³) according to EN 12467 | approx. 1,150 |
| Bending strength (MPa) according to EN 12467 | ≥ 7 |
| Tensile strength perpendicular to the plane of the board (N/mm ²) according to EN 319 | 0.65 |
| Shearing strength (N) according to EN 520 | 607 |
| pH-value | 12 |
| Thermal conductivity (W/mK) according to EN ISO 10456 | 0.35 |
| Thermal expansion (10 ⁻⁶ K ⁻¹) | 7 |
| Water vapour diffusion coefficient μ (-) according to EN ISO 12572 | 66 |
| Length variation 65% - 85% humidity (mm/m) according to EN 318 | 0.23 |
| Thickness variation 65% - 85% humidity (%) according to EN 318 | 0.2 |
| Building material class according to EN 13501 | A1 non-combustible |
| Certificate of conformity (COC) according to BS 476-4:1970 (Singapore) | non-combustible |
| Fungus Resistance according to ASTM D3273-16 | Rating 10 (0 defacement by mold growth) |
| Fungus Resistance according to ASTM G21-15 | Rating 0 (No fungal growth) |



New design possibilities for curved walls

With a bending radius of 3 metres (full board) and 1 m (300 mm strips), AQUAPANEL® Cement Board Outdoor allows designers to introduce a variety of curved shapes and creative designs, including domes and arches. Moreover, by using double studs, it's possible to create different interiors and exteriors: for example, a wall that's concave on the outside, and convex on the inside.

Lingang Warehouse | Shanghai, China

Arrangement of AQUAPANEL® Cement Board Outdoor with different radius

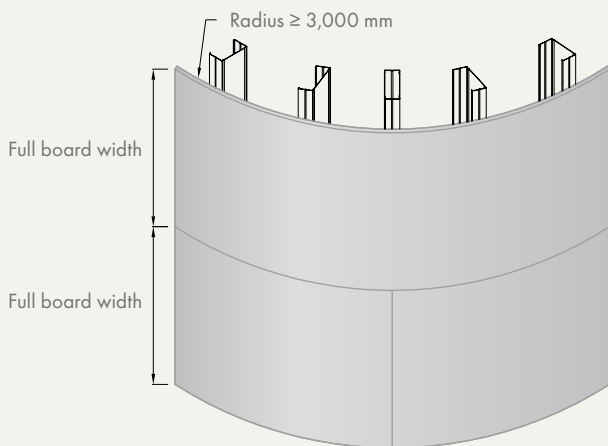

Assembly with full board size panels for radius $\geq 3,000$ mm

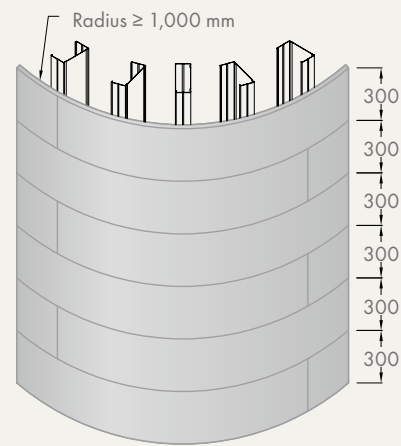

Assembly with 300 mm width panels for radius $\geq 1,000$ mm

DEDICATED SYSTEM SOLUTIONS

AQUAPANEL® Exterior Wall – rear-ventilated rainscreen facade

With rainscreen facades for use above solid substructures, such as brick or concrete, thermal insulation is separated from the weather protection materials ensuring a constant flow of air in the ventilated space to remove moisture from the building and to optimise indoor climate. Even if the facade is damaged, the insulation remains intact.



AQUAPANEL® Exterior Wall – drywall solution

Drywall systems are available as single stud solutions with a variety of creative design options. And although it is most commonly used in skeleton constructions comprising reinforced concrete, drywall is also suitable for timber or lightweight steel-frame constructions.

AQUAPANEL® Exterior Ceiling

Ideal drylining solution for exterior ceilings, such as soffits, undersides of balconies, underpasses, and underground car parks with proven resistance to moisture or mildew forming and spreading. For greater safety and the highest standards in design, construction, cost-effectiveness, and durability.

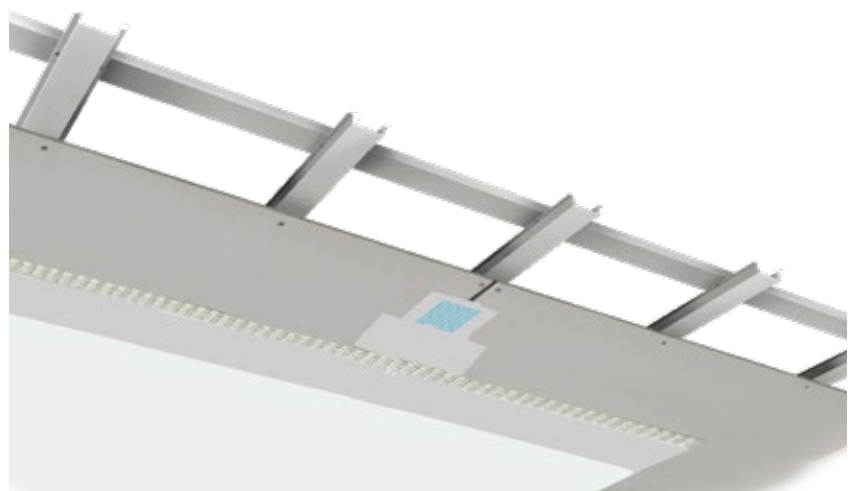

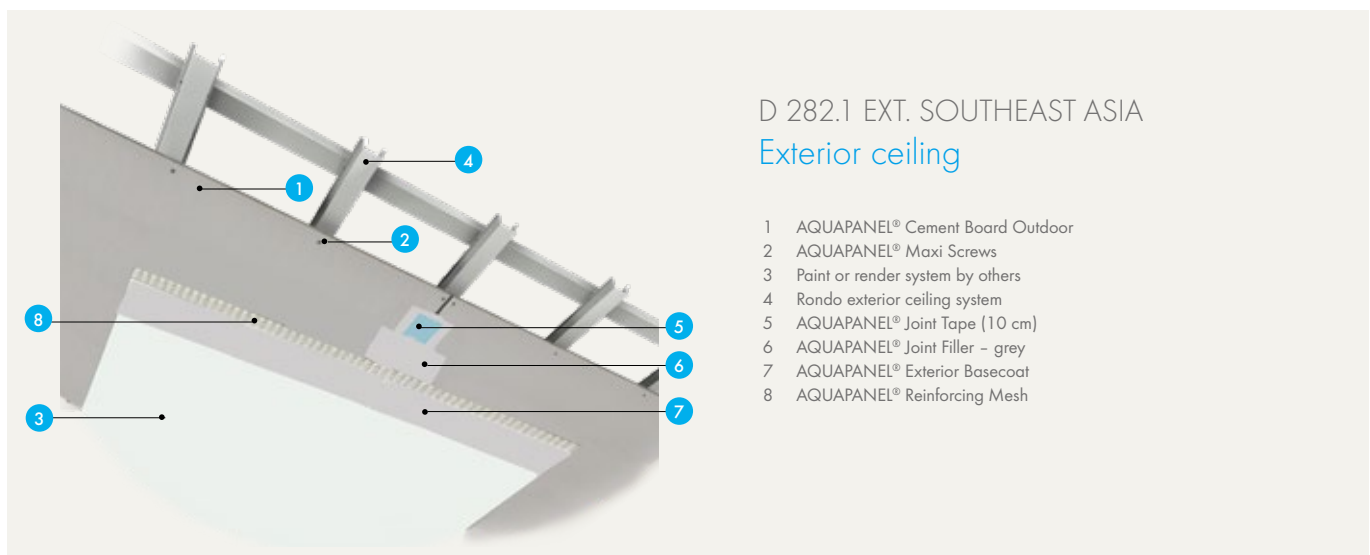
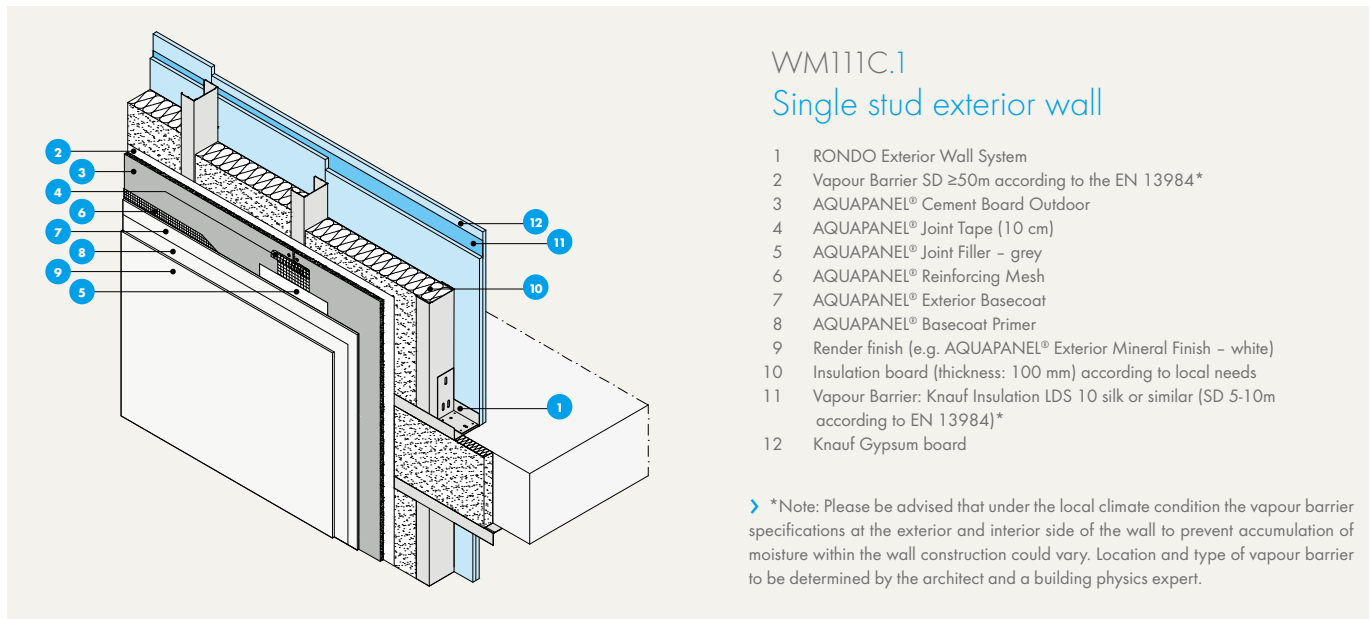
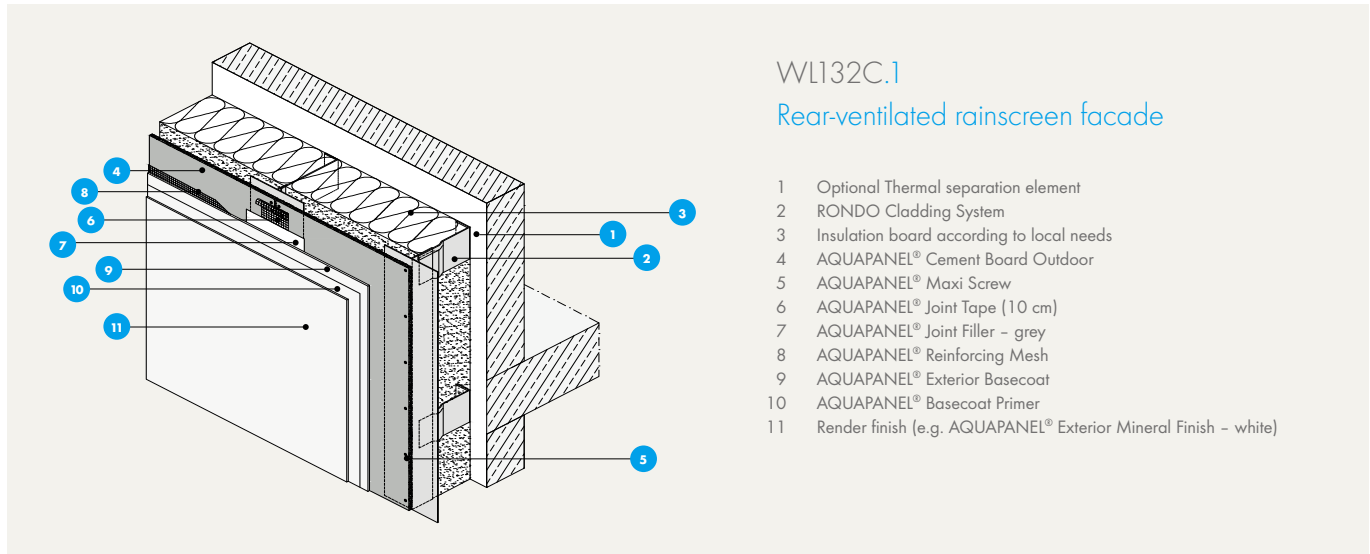

EXTERIOR PROJECTS



Lingang Warehouse | Shanghai, China



Markor Art Center | Beijing, China



Mercedes Showroom | Ypres, Belgium



Starbucks | Daecheon, Republic of Korea



Joali | Maldives



Hunan Broadcasting System Program Production Center | China

BENEFIT FROM THE VALUABLE SERVICES FROM AQUAPANEL®



AQUAPANEL® WEBSITE



INTERNATIONAL TRAINING CENTRE



YOUTUBE CHANNEL

Discover a world of online resources and support available 24/7 to help you understand and communicate the full scope of the AQUAPANEL® family. Find and download up to date in-depth technical documents, videos, and the latest materials.

› www.aquapanel.com

Stay in the loop and keep your knowledge at the cutting edge with professional, practical seminars from the AQUAPANEL® International Training Centre. With courses designed to give you and your people fresh insights and understanding, you get a unique advantage. For more information, please contact your local AQUAPANEL® partner or email us:

› aquapanel.info@knauf.com

See AQUAPANEL® in action. Our YouTube channel features product introductions and how-to videos on everything from installation to finishing options and curved wall constructions. It's all available any time - and we'll be regularly updating the channel with our latest videos, making it the first place to go for new AQUAPANEL® content.

› www.youtube.com

Search: Knauf Aquapanel

All technical changes reserved. Only the current printed instructions are valid. Our warranty is expressly limited to our products in flawless condition. The constructional and structural properties and characteristic building physics of Knauf systems can solely be ensured with the exclusive use of Knauf system components, or other products expressly recommended by Knauf. All application quantities and delivery amounts are based on empirical data that are not easily transferable to other deviating areas. All rights reserved. All amendments, reprints and photocopies, including those of excerpts, require the express permission of Knauf Aquapanel GmbH & Co. KG, Zur Helle 11, 58638 Iserlohn, Germany. AQUAPANEL® is a registered trademark.

Knauf Aquapanel GmbH & Co. KG

**Zur Helle 11
58638 Iserlohn
Germany**