

KNAUF

PARTIWALL[®] ***MANUAL***

*Separating Walls for Class 1a
Buildings Steel Framed*



Build on us.

All works undertaken to prescribe the use of or to install Knauf's products and systems must be performed by experienced and, where required by applicable laws, appropriately licensed personnel. Knauf's products and systems must be installed in accordance with Knauf's installation manual, Systems+, and any other product or system specific literature issued by Knauf. If installation works are not performed in compliance with such product literature, by experienced and licensed personnel, or are incorrectly performed by experienced or licensed personnel, there is a serious risk that the works, application and performance of the relevant system or products will be compromised, which could result in property damage, injury or death.

All personnel who undertake works to install Knauf's products and systems must comply with all applicable health and safety laws, including wearing appropriate personal protection equipment. If personnel do not comply with applicable health and safety laws, including by not wearing appropriate personal protection equipment, there is a serious risk of injury or death.

All of Knauf's products and systems must only be used for the uses identified in this document (and any other product or system specific literature issued by Knauf from time to time). Before prescribing or using any Knauf product or system for any other use, you must contact Knauf. All recommended component parts for Knauf's products and systems should be used and not substituted for other products. If component parts are substituted, there is a serious risk that the works, application and performance of the relevant system or products will be compromised, which could result in property damage, injury or death.

This product manual is intended to provide general information on plasterboard products and should not be used as a substitute for professional building advice. We recommend you use a qualified person to install Knauf plasterboard. To ensure the information you are using is current, Knauf recommends you review the latest building information available on the Knauf website Knauf.com. For further information contact TecASSIST or your Knauf representative.

Content

1 GENERAL INFORMATION

Introduction	4
Description	4
Features and Benefits	5
Design Options	5
Standards	5
PartiWall Design Concept	6

2 DESIGN CONSIDERATIONS

Fire Resistance	8
Fire Hazard Properties	8
Acoustics	8
Isolated Support for Stairs	9
Wet Areas	9
Mould Resistance	9
Structural	9
Maximum Permissible Height	9
Framing	9
PartiWall Clip Arrangement	9
PartiWall H-Stud Alignment and Back-To-Back Tracks	10
Construction Joints	10
Wind Speed	10
Seismic	10
Concrete Fasteners	10

3 MATERIALS

Shaftliner MouldStop Fire Barrier	11
Occupancy Linings	12
Jointing Compounds	12
Jointing Tapes	12

4 PARTIWALL SYSTEMS

PWS60.1	13
PWS90.1	14

5 INSTALLATION OF SHAFTLINER MOULDSTOP FIRE BARRIER

Set Out and Fixing	15
Protection from Weather	15
Dos and Don'ts	15
Installation Procedure	16-18

6 INSTALLATION DETAILS

Installation Details	19-33
----------------------	-------



PARTIWALL

Introduction

The pioneering system of its kind in Australia, Knauf PartiWall has become one of the most widely used separating wall systems in attached villa units and townhouse construction.

Excellent acoustic performance, ease of construction and design flexibility make PartiWall the system of choice for projects ranging from side-by-side duplexes to multi-unit developments.

PartiWall is suitable for attached dwellings Class 1a and for top storeys of Class 2 and 3 buildings (subject to Certifier's approval). Contact Knauf TecASSIST for advice.

For multi-residential buildings Class 2, 3 and 9C, Knauf recommends the Multiframe timber-framed construction system (subject to NCC limitations) or IntRwall separating wall system.

Description

PartiWall is a twin stud wall system, which incorporates a 25 mm Shaftliner MouldStop plasterboard fire barrier within the wall cavity.

PartiWall was developed to suit the normal pattern of framed construction and follow-up trades. Shaftliner MouldStop panels are held in position by lightweight steel H- or I-section studs attached to steel or timber framing on both sides with aluminium clips.

Installation of a Shaftliner MouldStop fire barrier is carried out during the framing stage and does not require plasterboard screw fixing, jointing or finishing. The internal wall linings are installed at the plastering stage using conventional installation methods, as outlined in the Knauf Plasterboard Installation Manual.



GENERAL INFORMATION

Features and Benefits

- No wet trades are required
- Panelised construction of Shaftliner MouldStop fire barrier permits easy installation at framing stage, with no additional trades required
- Permits easy inclusion of services and penetrations such as switches, power points, light fittings and pipes, without the need for fire proofing
- Internal wall linings are installed at the plastering stage, as per normal construction sequence

Design Options

Knauf PartiWall has been tested and certified to meet Fire Resistance Levels (FRL) of 60/60/60 and 90/90/90 and acoustic performance equal to or exceeding $R_w + C_{tr}$ 50, as required by the National Construction Code (NCC).

PartiWall systems are available in three basic types:

Table 1: PartiWall Steel System Configuration

System Type	Fire Barrier	FRL
PWS60.1	1 x 25 mm Shaftliner MouldStop	60/60/60
PWS90.1	1 x 25 mm Shaftliner MouldStop + 1 x 16 mm FireStop	90/90/90
PWS90.2 [^]	2 x 25 mm Shaftliner MouldStop	90/90/90

[^] System PWT90.2 is not covered in this manual. For acoustic performance refer to Knauf Eselector and BIM Wizard. For construction details contact TecASSIST.

Notes

This manual covers steel framed PartiWall systems only. For information on timber framed PartiWall systems, refer to the Knauf PartiWall Manual - Timber Framed.

All system types are available with a wide range of outer linings on one or both sides of the wall.

Construction details are provided for aligned and offset floor configurations, internal-to-external wall transitions, various roof types, flat clips, cantilever and roof penetrations.

All construction details contained in this manual have been certified by the CSIRO assessment report number FCO-3359.

Figure 1: Cantilever PartiWall

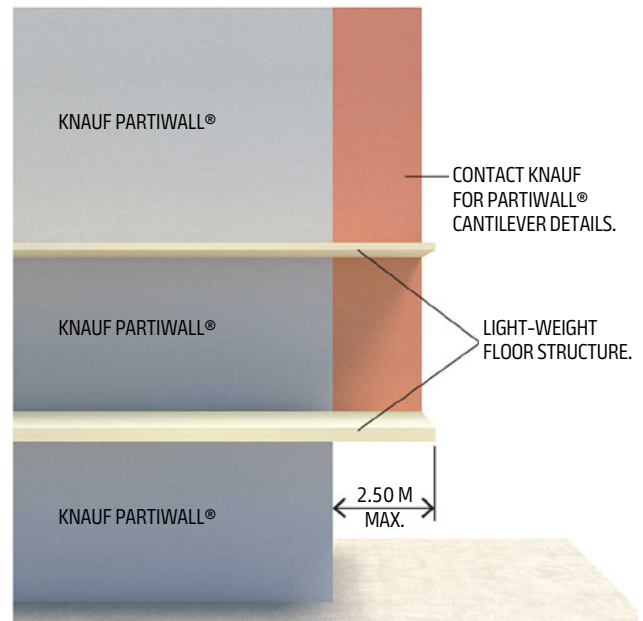

Notes

A cantilever PartiWall option is also available for overhanging floors. Refer to Figure 36 or contact Knauf for further information.

Standards

The following Australasian Standards associated with the PartiWall system:

- AS/NZS 2588 Gypsum plasterboard
- AS/NZS 2589 Gypsum linings – Application and finishing
- AS/NZS 1170.2 Structural Design Actions – Wind actions
- AS/NZS 1170.4 Structural Design Actions – Earthquake Actions
- AS 4055 Wind loads for housing
- AS 3999 Bulk thermal insulation – installation
- AS 1397 Steel sheet and strip – hot dipped, zinc coated or aluminium/zinc coated
- AS 3566 Self-drilling screws for the building and construction industries
- AS/NZS 4600 Cold-formed steel structures
- AS/NZS 5216 Fastenings in concrete
- AS/NZS 1530.4 Methods for fire tests on building materials
- AS/NZS 3837 Method of test for Heat and Smoke Release Rates for Materials and Products using an Oxygen Consumption Calorimeter
- AS 1191 Acoustics – Method for Laboratory Measurement of Airborne Sound Transmission Insulation of Building Elements
- AS/NZS ISO 717.1 Acoustics – Rating of Sound Insulation in Building and of Building Elements, Part 1: Airborne Sound Insulation.

GENERAL INFORMATION CONT.

Figure 2: PartiWall Design Concept

Figure 2.1: Before the fire



Figure 2.2: During the fire



PartiWall Design Concept

In a conventional fire-rated wall system, the fire-resistant outer linings protect the wall substrate. However, in the PartiWall system, the primary fire barrier is located within the wall cavity. This barrier is specifically designed to protect the structure on the side opposite the fire.

The Shaftliner MouldStop fire barrier relies on the structure for support, as the structure on the fire side may lose stability or collapse during a fire. To prevent damage to the fire barrier from the collapsing structure, aluminium clips are used to attach it to the steel frames on both sides. When the clips on the fire side melt, the Shaftliner MouldStop fire barrier disconnects from the collapsing structure. It remains supported by the clips and the structure on the protected side, maintaining its integrity for the specified fire-rating period.

Notes

Steel clips **MUST NOT** be used in the PartiWall system as their use will compromise the integrity of the Shaftliner MouldStop during the fire.

Figure 2.3: After the fire

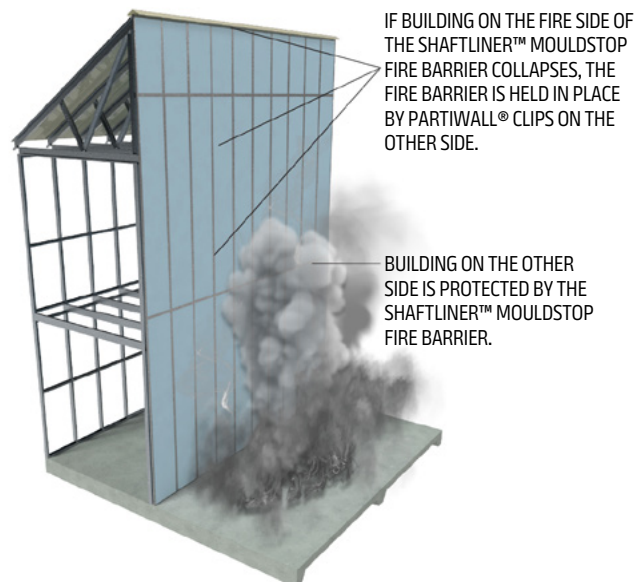

GENERAL INFORMATION CONT.

Figure 3: PartiWall Construction Sequence

Stage 1

- Ground Floor frame installed on one side
- Ground Floor fire barrier installed and clipped
- FireStop plasterboard is fixed at 1st Floor as required

Stage 2

- Ground Floor frame installed on opposite side
- Ground Floor fire barrier clipped on opposite side

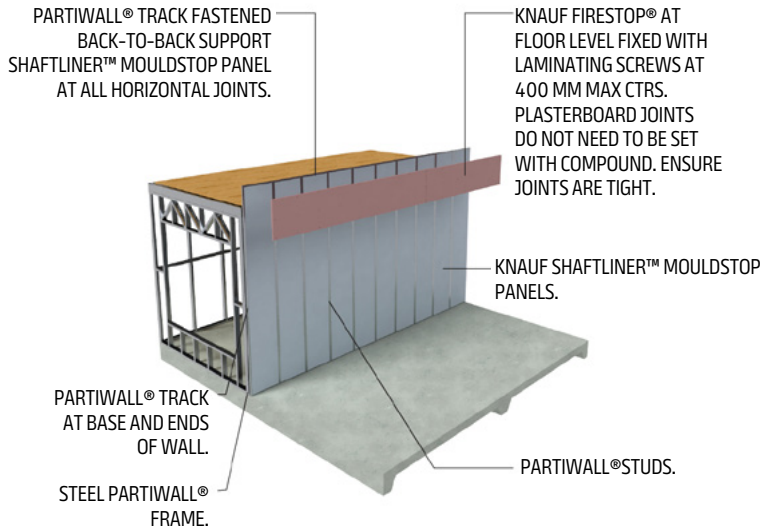

Stage 3

- 1st Floor and roof frame installed on one side
- 1st Floor and roof fire barrier installed and clipped
- FireStop plasterboard fixed within the roof space

Stage 4

- 1st Floor and roof frame installed on opposite side
- 1st Floor and roof fire barrier clipped on opposite side

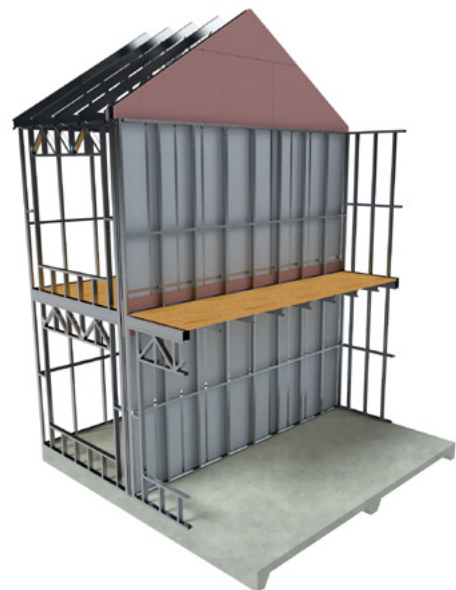
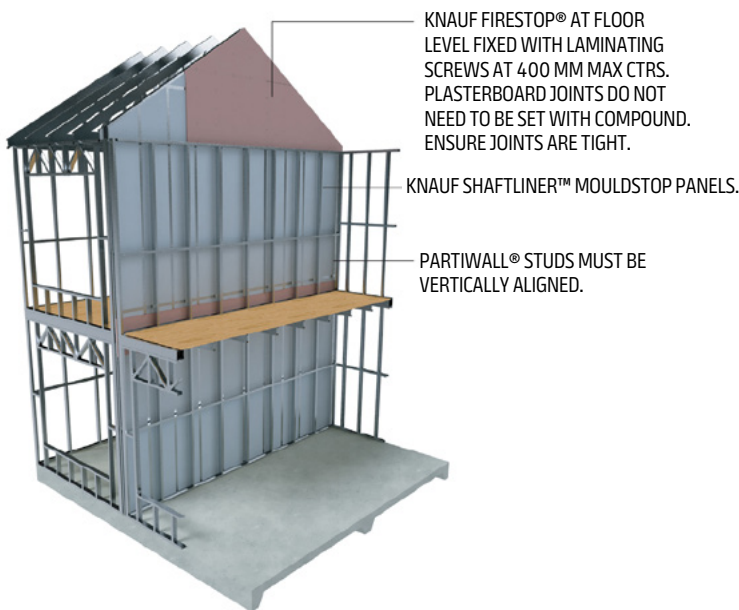

DESIGN CONSIDERATIONS

Fire Resistance

The PartiWall system has been fire tested at CSIRO's laboratory at North Ryde in Sydney. The performance of various system configurations have been assessed in CSIRO's reports: FSV-0381 and FCO-3359 and BRANZ's report FC16905-01-1.

The PartiWall system provides Fire Resistance Levels (FRL) of 60/60/60 and 90/90/90. In the case of a fire, the structural adequacy and load bearing capacity is provided by the wall frame on the other side of the Shaftliner MouldStop fire barrier.

As the primary fire barrier (the Shaftliner MouldStop panels) is located in the cavity between the frames, the system permits easy inclusion of services such as water and waste pipes, electrical and communications cables, as long as the primary fire barrier is not penetrated. Service penetrations are allowed through Shaftliner MouldStop fire barrier in the roof space subject to Certifier's approval (refer Installation Details).

The following penetrations – individually or in combinations, or back-to-back are allowed in the outer linings and are not required to be fire-rated:

- Normal residential electrical switches and power points
- Data, communications or electrical cables passing through the linings into the cavity
- Copper, galvanized steel, or plastic water or wastewater pipes of up to 50 mm nominal diameter passing through the linings into the cavity
- Cabinets, baths, shower bases or vanities
- For other penetrations contact Knauf TecASSIST.

Fire Hazard Properties

Knauf plasterboard linings have been tested to AS/NZS 3837 – Method of Test for Heat and Smoke Release Rates for Materials and Products using an Oxygen Consumption Calorimeter. These tests were conducted in accordance with AS 5637.1 to determine their Group Number Classification, as required by NCC Specification S7C4 Fire Hazard Properties – Walls and Ceilings.

The following Knauf plasterboard linings have achieved a Group 1 classification and have an Average Specific Extinction Area of less than 250 m²/kg, making them suitable for use in buildings not fitted with a sprinkler system, in accordance with BRANZ Assessment Report FC13971:

- 25 mm Shaftliner MouldStop
- 16 mm FireStop
- 10/13 mm SHEETROCK ONE
- 10 mm SHEETROCK PLUS
- 13 mm WetStop
- 13 mm ImpactStop.

Acoustics

The PartiWall system has been the subject of extensive laboratory testing at the CSIRO Acoustic Laboratory at Highett, Victoria.

Acoustical opinions have been determined by Renzo Tonin and Associates Pty Ltd in opinion number RT&A TE405-20S06(r2).

PartiWall satisfies NCC acoustic provisions for Class 1a buildings of $R_w + C_{tr}$ 50 for separating walls and $R_w + C_{tr}$ 25 and $R_w + C_{tr}$ 40 acoustic separation of adjoining soil and waste pipes within the cavity.

Figure 4: PartiWall Services Separation

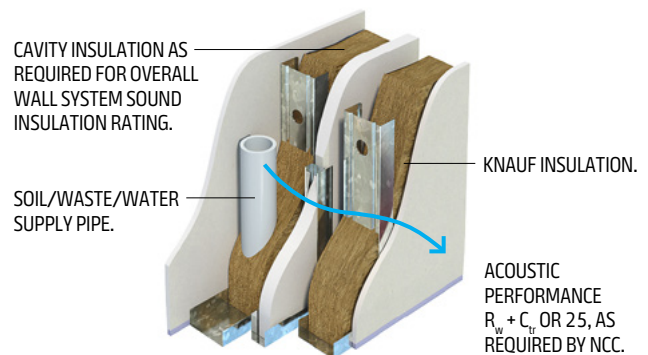

Small penetrations of linings in occupancy areas, i.e. switches, power points, light fittings and pipes, do not need to be fire or acoustically sealed. Knauf Insulation must be used within PartiWall system to achieve specified acoustic rating. Insulation thicker than the stud framing is acceptable, but is limited to the cavity size of the system.

PartiWall complies with NCC requirements for '**discontinuous construction**'.

DESIGN CONSIDERATIONS CONT.

Isolated Support for Stairs

In order to reduce the likelihood of stair footfall noise passing through the wall into the attached dwelling, it is recommended that stairs should be isolated from the separating wall as follows:

- Using stringers to support the stairs, at each floor level, without intermediate support from the separating wall in between (i.e. free standing), or alternatively:
 - Using newel posts rather than the separating wall to support the stair structure
 - Keeping the treads clear of the separating wall.

The following requirements are essential to maintaining the fire-rating integrity and acoustic performance of the PartiWall system:

- Use only the specified PartiWall aluminium clips to attach the PartiWall H-studs to steel framing members. In the event of a fire, aluminium clips are designed to melt to allow the steel framing on the fire side to fall away leaving the Shaftliner MouldStop fire barrier intact
- Other than the clips, there should be no attachments to the Shaftliner MouldStop fire barrier
- There should be no penetrations through the Shaftliner MouldStop fire barrier apart from approved penetrations in the roof space
- Shaftliner MouldStop fire barrier base must be sealed with Firesound sealant
- To maintain acoustic performance, service pipes must not be in contact with the Shaftliner MouldStop fire barrier. All services should be run through the framing
- The clear distance between the Shaftliner MouldStop fire barrier and wall framing on both sides should not be less than 20 mm and no more than 40 mm
- The 16 mm FireStop plasterboard laminated to the Shaftliner MouldStop fire barrier should not come into contact with wall or floor framing. It is recommended that the gap between Shaftliner MouldStop fire barrier and steel framing be increased to a minimum 25 mm on the FireStop side to ensure adequate clearance
- Knauf Insulation must be used to achieve the specified system performance.

Wet Areas

Water resistant wall linings must be used in areas classified as Wet Areas in accordance with the NCC. PartiWall systems are available with the following water-resistant linings on one or both sides:

- 10 mm SHEETROCK PLUS
- 13 mm WetStop
- 6 mm Villaboard fibre cement.

For installation details of Knauf Wet Area Systems refer to the Knauf Plasterboard Installation Manual.

Knauf Wet Area Systems comply with the requirements of AS 3740 and is thus suitable for use in residential buildings and other buildings with a similar usage pattern.

Mould Resistance

All Shaftliner panels are now manufactured as Shaftliner MouldStop.

Shaftliner MouldStop contains the added advantage of mould resistance and showed zero signs of mould growth when tested in accordance with ASTM D3273 and ASTM G21.

Structural

Maximum Permissible Height

Height of the standard Shaftliner MouldStop fire barrier should not exceed 12 metres:

Figure 5: Shaftliner MouldStop Maximum Height Structure

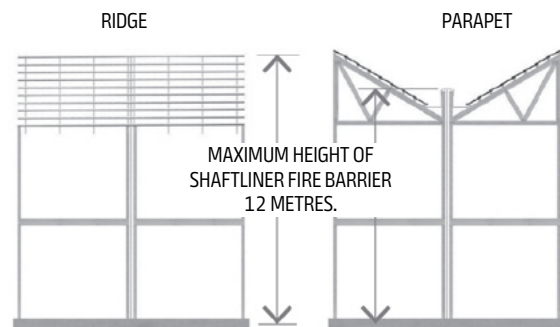

Notes

Heights of up to 15 metres can be achieved with special detailing. Contact Knauf TecASSIST for further information.

Framing

Steel framing must be designed by a suitably qualified Structural Engineer to meet NCC requirements, and in accordance with AS 4600 Cold-formed Steel Structures and other relevant Australian Standards. Stud spacings must not exceed 600 mm centres.

PartiWall Clip Arrangement

Every PartiWall stud and end track must be fixed on both sides of the fire barrier to the steel framing with PartiWall aluminium clips, as per the installation details.

Clips on each side of the Shaftliner MouldStop fire barrier must be spaced at no more than 3000 mm vertically and 600 mm horizontally.

DESIGN CONSIDERATIONS CONT.

Figure 6: Clip Arrangement For Maximum 12 m Fire Barrier Height

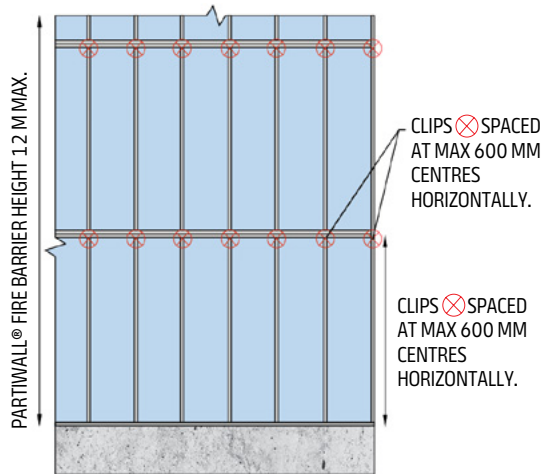

Notes

- 3 m Shaftliner MouldStop panels shown in figure.
- Where the maximum height of the Shaftliner MouldStop fire barrier is less than 7.5 m a reduction in PartiWall aluminium clips is possible. For clip reduction details and project compliance please contact Knauf TecASSIST.

PartiWall H-Stud Alignment and Back-To-Back Tracks

Continuous PartiWall tracks must be fixed back-to-back with 10 g x 16 mm drill point wafer head Type 'D' screws at all Shaftliner MouldStop horizontal joints.

It is recommended that when installing Shaftliner MouldStop panels and PartiWall studs, that studs above align with studs below. In this case back-to-back PartiWall tracks can be fixed at max 600 mm centres.

Figure 7: PartiWall H-Studs Aligned

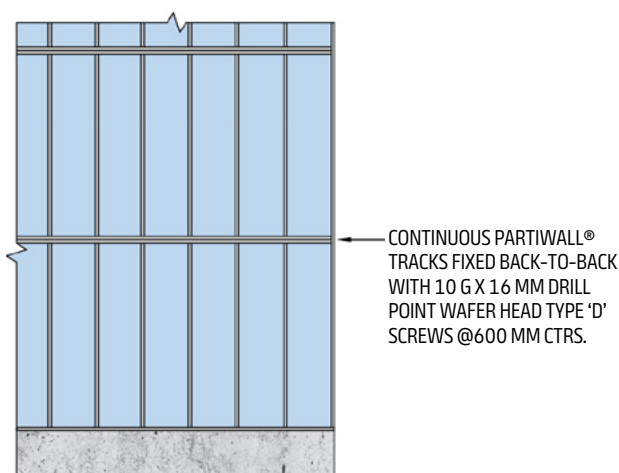

If Shaftliner MouldStop panels and PartiWall studs do not align with the studs below, back-to-back PartiWall tracks must be fixed at max 300 mm centres.

Construction Joints

Where construction joints are necessary in PartiWall, contact Knauf TecASSIST 1800 811 222 for construction details.

Figure 8: PartiWall H-Studs Staggered

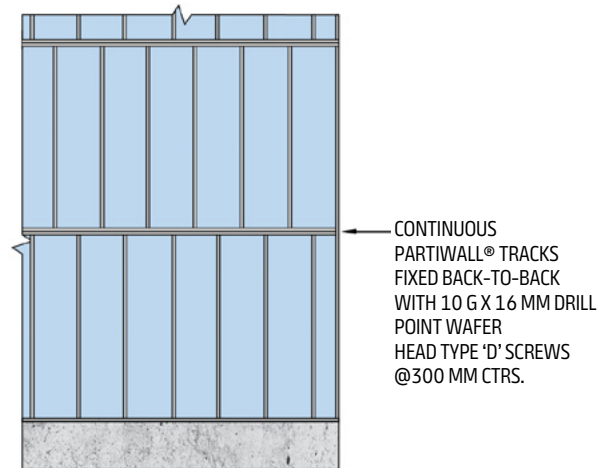

Notes

- PartiWall clips must be spaced at no more than 3000 mm vertically and 600 mm horizontally on both sides of fire barrier regardless of H-stud alignment.

Wind Speed

PartiWall is suitable for wind classification N1 and N2 as determined by AS 4055 Wind loads for housing. For higher wind classifications, Knauf recommends temporary propping of the Shaftliner MouldStop fire barrier during construction until the building is enclosed.

Propping details are to be designed by a suitably qualified Structural Engineer. When PartiWall is proposed in cyclonic areas, contact Knauf TecASSIST for advice.

Seismic

PartiWall has been seismically assessed by Lapish Enterprises Ltd report number EL9111C4, in accordance with AS1170.4. It is suitable for use in earthquake zones where the Earthquake Hazard Factor (Z) is 0.12 or less, only if the aluminium support clips are adequately spaced on both sides of the Shaftliner MouldStop fire barrier as indicated in the details, and when the adjacent framing members have been adequately designed to withstand the project's specific design seismic forces.

The load bearing steel stud framing must be designed by a qualified Structural Engineer and in accordance with AS4600 Cold-formed Steel Structures, AS1170.4 Earthquake actions in Australia and other relevant Australian Standards.

Concrete Fasteners

Concrete fasteners to be spaced at 600 mm max centres. Fasteners must be designed by the Project Engineer in accordance with AS5216 and all other relevant Australian Standards and provisions of the National Construction Code. Fastener manufacturer/supplier to provide compliance documentation to ensure design intent is satisfied.

Notes

















- Nylon anchors and drive pins are not acceptable fasteners.
- Suitable fasteners include Rondo CERT-R-FIX or equivalent. Refer Rondo for details.

MATERIALS

Shaftliner MouldStop Fire Barrier

Materials used in construction of Shaftliner MouldStop fire barrier are listed in the following table:

Table 2: Shaftliner MouldStop Fire Barrier Components

Knauf Item Codes	Item Description	Product Image	Knauf Item Codes	Item Description	Product Image
00818588	25 mm Shaftliner MouldStop 600 x 3000 mm		00832942	6 g x 25 mm Type 'S' Steel Screws	
00818589	25 mm Shaftliner MouldStop 600 x 3600 mm		Refer to Knauf	10 g x 40 mm Type 'L' Laminating Screws Pkt 1000	
00817941	16 mm FireStop 1200 x 2400 mm		00832982	10 g x 16 mm Type 'D' Drill Point Wafer Head Screws	
00824030	25 mm H-Stud x 3000 mm	PartiWall Stud 	00832984	10 g x 30 mm Type 'D' Drill Point Wafer Head Screws	
00824031	25 mm H-Stud x 3600 mm		00824145	Cert-R-Fix Screw Bolts HH RCH06 M6 x 43	
00757543	25 mm Wall track 3000 mm (Rondo P140)	PartiWall Track 	00820308	Knauf Firepack Mineral Wool Packer 5 m x 200 x 50 mm Pkt 3	
00817659	25 mm Wall track 3600 mm (Rondo P140)		00820255	Firesound Mastic 450 g Tube	
00817836	Aluminium Clip	PartiWall Clip 	Refer to Knauf	90 mm Knauf Insulation Glasswool 11 kg /m ³ Density	
00826209	Flat Aluminium Clip	PartiWall Flat Clip 		90 mm Knauf Insulation Glasswool 24 kg /m ³ Density	

Notes

PartiWall performance values stated in this manual are based on the use of materials and components listed herein. Material substitution is not permitted and may affect the performance of the PartiWall systems.

MATERIALS *CONT.*

Occupancy Linings

The following linings are typically used in occupancy areas:

- 10/13 mm SHEETROCK ONE
- 10 mm SHEETROCK PLUS
- 13 mm WetStop
- 13 mm ImpactStop
- 6 mm Villaboard fibre cement.

Jointing Compounds

Knauf offers a wide range of setting and air-drying jointing compounds suitable for a variety of application methods and requirements.

Bedding and base compounds to be used with jointing tape:

- BaseCote 45 20 kg
- BaseCote 60 20 kg
- BaseCote 90 20 kg
- RediBase 18 kg.

Finishing compounds:

- SHEETROCK Total LITE 17.5 kg
- LiteFinish 18 kg
- FinalCote 20 kg.

Jointing Tapes

Jointing tapes are used to provide reinforcement to plasterboard joints and angles.

Paper tape is recommended by Knauf for jointing of gypsum wall and ceiling linings due to its high strength and suitability for all jointing compounds and applications.

Paper jointing tape must be used in wet area and fire-rated applications and with air-drying type jointing compounds.

For more information please refer to our plasterboard installation manual.



PARTI WALL SYSTEMS

Table 3: System PWS60.1

Fire Resistance Level LB 60/60/60 From both sides FRL Basis: FCO-3359	Acoustic Ratings Basis: RT&A TK778-26F01				Discontinuous Construction			
	System	Side 1		Side 2		Insulation (both cavities)	Nom. Wall Width (mm)	R _w (R _w +C _{tr})
		Lining	Stud Size (gap) mm	Lining	Stud Size (gap) mm			
 <p>System Description</p> <p>Side 1:</p> <ul style="list-style-type: none"> Lining (refer to table) Steel framing 20 mm min gap between steel frame and fire barrier <p>Insulation (refer to table)</p> <p>Fire Barrier:</p> <ul style="list-style-type: none"> 1 x 25 mm Shaftliner MouldStop between 25 mm H-studs @600 mm ctrs <p>Side 2:</p> <ul style="list-style-type: none"> Lining (refer to table) Steel framing 20 mm min gap between steel frame and fire barrier <p>Insulation (refer to table)</p>	PWS60.1A	1 x 10 mm SHEETROCK PLUS	70(40)	1 x 10 mm SHEETROCK PLUS	70(40)	KI 90G14	265	63(50)
		1 x 10 mm SHEETROCK PLUS	90(20)	1 x 10 mm SHEETROCK PLUS	90(20)			
	PWS60.1D	1 x 13 mm SHEETROCK ONE	70(40)	1 x 13 mm SHEETROCK ONE	70(40)	KI 90G14	271	63(50)
		1 x 13 mm SHEETROCK ONE	90(20)	1 x 13 mm SHEETROCK ONE	90(20)			
	PWS60.1E	1 x 13 mm SHEETROCK ONE	70(40)	1 x 13 mm WetStop	70(40)	KI 90G11	271	63(50)
		1 x 13 mm SHEETROCK ONE	90(20)	1 x 13 mm WetStop	90(20)			
	PWS60.1F	1 x 13 mm SHEETROCK ONE	70(40)	1 x 6 mm Villaboard	70(40)	KI 90G14	264	63(50)
		1 x 13 mm SHEETROCK ONE	90(20)	1 x 6 mm Villaboard	90(20)			
	PWS60.1G	1 x 13 mm WetStop	70(40)	1 x 13 mm WetStop	70(40)	KI 90G11	271	62(50)
		1 x 13 mm WetStop	90(20)	1 x 13 mm WetStop	90(20)			
	PWS60.1H	1 x 13 mm ImpactStop	70(20)	1 x 13 mm ImpactStop	70(20)	KI 90G11	231	65(52)
		1 x 13 mm ImpactStop	70(40)	1 x 13 mm ImpactStop	70(40)	KI 90G11 (one cavity only)	271	58(50)
		1 x 13 mm ImpactStop	90(20)	1 x 13 mm ImpactStop	90(20)			
	PWS60.1I	1 x 13 mm ImpactStop	70(20)	1 x 13 mm WetStop	70(20)	KI 90G11	231	60(50)
		1 x 13 mm ImpactStop	70(40)	1 x 13 mm WetStop	70(40)	KI 90G11 (one cavity only)	271	58(50)
		1 x 13 mm ImpactStop	90(20)	1 x 13 mm WetStop	90(20)			
	PWS60.1J	1 x 13 mm ImpactStop	70(20)	1 x 6 mm Villaboard	70(20)	KI 90G11	224	60(50)
		1 x 13 mm ImpactStop	70(40)	1 x 6 mm Villaboard	70(40)	KI 90G11 (one cavity only)	264	58(50)
1 x 13 mm ImpactStop		90(20)	1 x 6 mm Villaboard	90(20)				
PWS60.1Q	1 x 6 mm Villaboard	70(40)	1 x 6 mm Villaboard	70(40)	KI 90G11	257	63(50)	
	1 x 6 mm Villaboard	90(20)	1 x 6 mm Villaboard	90(20)				

* KI 90G11 - 90 mm Knauf Insulation Glasswool 11 kg/m³ density.
KI 90G24 - 90 mm Knauf Insulation Glasswool 14 kg/m³ density.

PARTIWALL SYSTEMS CONT.

Table 4: System PWS90.1

Fire Resistance Level LB 90/90/90 From both sides	Acoustic Ratings Basis: RT&A TK778-26F01				Discontinuous Construction				
	System	Side 1		Side 2		Insulation (both cavities)	Nom. Wall Width (mm)	R _w (R _w +C _{tr})	
		Lining	Stud Size (gap) mm	Lining	Stud Size (gap) mm				
FRL Basis: FC16905  <p>System Description</p> <p>Side 1:</p> <ul style="list-style-type: none"> • Lining (refer to table) • Steel framing • 20 mm min gap between steel frame and fire barrier • Insulation (refer to table) <p>Fire Barrier:</p> <ul style="list-style-type: none"> • 1 x 25 mm Shaftliner MouldStop between 25 mm H-studs • @600 mm ctrs + 1 x 16 mm FireStop laminated to Shaftliner MouldStop @400 ctrs <p>Side 2:</p> <ul style="list-style-type: none"> • Lining (refer to table) • Steel framing • 20 mm min gap between steel frame and fire barrier • Insulation (refer to table) 	PWS90.1A	1 x 10 mm SHEETROCK PLUS	70(20)	1 x 10 mm SHEETROCK PLUS	70(20)	KI 90G11	241	63(50)	
		1 x 10 mm SHEETROCK PLUS	70(40)	1 x 10 mm SHEETROCK PLUS	70(40)		KI 90G11	281	64(52)
		1 x 10 mm SHEETROCK PLUS	90(20)	1 x 10 mm SHEETROCK PLUS	90(20)			287	69(55)
	PWS90.1E	1 x 13 mm SHEETROCK ONE	70(40)	1 x 13 mm SHEETROCK ONE	70(40)	KI 90G11	287	69(55)	
		1 x 13 mm SHEETROCK ONE	90(20)	1 x 13 mm SHEETROCK ONE	90(20)				
	PWS90.1F	1 x 13 mm SHEETROCK ONE	70(40)	1 x 13 mm WetStop	70(40)	KI 90G11	284	70(57)	
		1 x 13 mm SHEETROCK ONE	90(20)	1 x 13 mm WetStop	90(20)				
	PWS90.1G	1 x 13 mm SHEETROCK ONE	70(40)	1 x 6 mm Villaboard	70(40)	KI 90G11	277	70(57)	
		1 x 13 mm SHEETROCK ONE	90(20)	1 x 6 mm Villaboard	90(20)				
	PWS90.1I	1 x 13 mm ImpactStop	70(20)	1 x 13 mm ImpactStop	70(20)	KI 90G11 (one cavity only)	287	62(50)	
		1 x 13 mm ImpactStop	70(40)	1 x 13 mm ImpactStop	70(40)				
		1 x 13 mm ImpactStop	90(20)	1 x 13 mm ImpactStop	90(20)				
	PWS90.1K	1 x 13 mm ImpactStop	70(20)	1 x 13 mm WetStop	70(20)	KI 90G11 (one cavity only)	280	61(52)	
		1 x 13 mm ImpactStop	70(40)	1 x 13 mm WetStop	70(40)				
		1 x 13 mm ImpactStop	90(20)	1 x 13 mm WetStop	90(20)				
	PWS90.1L	1 x 13 mm ImpactStop	70(20)	1 x 6 mm Villaboard	70(20)	KI 90G11 (one cavity only)	287	61(52)	
		1 x 13 mm ImpactStop	70(40)	1 x 6 mm Villaboard	70(40)				
		1 x 13 mm ImpactStop	90(20)	1 x 6 mm Villaboard	90(20)				
PWS90.1R	1 x 6 mm Villaboard	70(40)	1 x 6 mm Villaboard	70(40)	KI 90G11	273	66(53)		
	1 x 6 mm Villaboard	90(20)	1 x 6 mm Villaboard	90(20)					

* KI 90G11 - 90 mm Knauf Insulation Glasswool 11 kg/m³ density.

Notes

PWS90.1 requires 16 mm FireStop to be laminated at the floor plenum and roof void on the opposite side of the Shaftliner MouldStop fire barrier, as per the installation procedure.

INSTALLATION OF SHAFTLINER MOULDSTOP FIRE BARRIER

Set Out and Fixing

Installation of the Shaftliner MouldStop fire barrier requires the attachment of PartiWall H-studs and end tracks to steel framing members using aluminium clips. Set out the steel framing to allow for the required clearances on both sides of the Shaftliner MouldStop fire barrier and later fixing of the PartiWall clips to wall tracks and roof frame.

After one side of the steel framing has been completed, install the Shaftliner MouldStop fire barrier and attach it to the completed frame with PartiWall aluminium clips. When framing on the other side is completed, attach the Shaftliner MouldStop fire barrier with PartiWall aluminium clips to that side.

The sequence of construction should be planned to accommodate progressive erection of the Shaftliner MouldStop fire barrier.

Protection from Weather

To prevent damage from the weather, all materials must be suitably protected during construction. Knauf recommends that exposure of the Shaftliner MouldStop fire barrier to the elements should be minimised, and that it should be protected if exposure is likely to exceed one month or when periods of intense inclement weather, such as heavy rain or high winds, are expected. Allow Shaftliner MouldStop panels to dry out before lining the occupancy areas.

Temporary exposure of Shaftliner MouldStop panels to moisture should not downgrade their fire resisting properties, as long as there is no physical damage to the panels in a wet state.

Knauf also recommends that concrete slabs on which the Shaftliner MouldStop fire barrier is erected should be level, free draining and free of depressions where water can collect, removing the possibility of the panel standing in water for any length of time. The specified 6 mm gap between the adjacent bottom track sections will facilitate drainage of water from the track.

Do

- **Do** provide min 20 mm clearance between Shaftliner MouldStop fire barrier and timber framing on both sides
- **Do** fix down PartiWall bottom track with approved concrete fasteners
- **Do** use aluminium clips at every PartiWall H-stud and end track and not more than 3000 mm above lower clip line or base track
- **Do** seal at PartiWall bottom track
- **Do** install Knauf Firepack at wall ends and top, as specified
- **Do** cut PartiWall studs and Shaftliner MouldStop panels to the same length
- **Do** align PartiWall studs above and below horizontal joint in Shaftliner MouldStop fire barrier
- **Do** insert PartiWall studs and Shaftliner MouldStop panels fully into the PartiWall base track
- **Do** insert Shaftliner MouldStop panels fully into the PartiWall H-studs
- **Do** use the specified fasteners for aluminium PartiWall clips
- **Do** use the specified Knauf Insulation to achieve the specified system performance

Don't

- **Don't** use damaged materials
- **Don't** penetrate the Shaftliner MouldStop other than in the roof space as per Knauf's specifications
- **Don't** exceed specified clip spacing
- **Don't** use steel clips
- **Don't** use PartiWall H-studs in lieu of PartiWall track as edge tracks, nor at horizontal joints in the Shaftliner MouldStop fire barrier
- **Don't** cut tracks between PartiWall studs. Tracks should be used in full lengths
- **Don't** run services in the gap between the Shaftliner MouldStop fire barrier and framework

INSTALLATION OF SHAFTLINER MOULDSTOP FIRE BARRIER *CONT.*

Installation Procedure (PWS60.1)

- Ensure that Shaftliner MouldStop panels, PartiWall studs and end tracks are the same length. Cut to length if required
- In a multi-level Shaftliner MouldStop fire barrier, PartiWall studs at upper levels are recommended to align with the studs below
- PartiWall aluminium clips must be installed progressively as the Shaftliner MouldStop fire barrier is erected
- PartiWall aluminium clips must be spaced at maximum 600 mm horizontally and 3000 mm vertically
- For aligned floors, PartiWall aluminium clips must be directly opposite on both sides of the PartiWall studs, unless noted otherwise
- For offset floors, PartiWall aluminium clips can be staggered in line with floors on each side of the wall
- Fix PartiWall aluminium clips to PartiWall studs with 2 x 10 g x 16 mm Type 'D' drill point wafer head screws (2 x 10 g x 30 mm Type 'D' drill point wafer head screws if fixing through 16 mm FireStop plasterboard)
- Fix PartiWall aluminium clip to steel frame with 2 x 6 g x 25 mm Type 'S' steel screws or 2 x 2.8 mm x 30 mm galvanised nail/clout
- Shaftliner MouldStop fire barrier must be adequately braced against wind forces until the building is enclosed
- When laminating 16 mm FireStop to fire barrier ensure butt joints fall centrally between PartiWall studs



Step 1: Install Base Track

- Use full track lengths, spaced 6 mm apart
- Position PartiWall track at min 20 mm clearance along full length of the steel frame, starting and ending in line with the steel frame
- Fix each track length to slab/foundation with approved concrete fasteners at 600 mm maximum spacing and at 150 mm maximum both ends

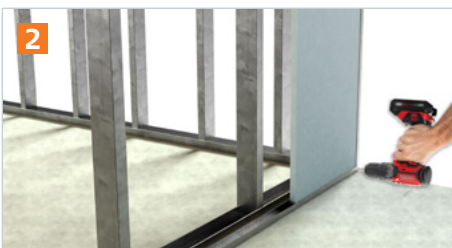

Step 2: Install First Shaftliner Mouldstop Panel

- To enable fixing of aluminium clip, cut the first Shaftliner MouldStop panel to width so that its edge falls not less than 50 mm from steel stud
- Fit Shaftliner MouldStop panel fully down into the PartiWall base track and align with end of track
- Fit PartiWall end track tightly over Shaftliner MouldStop panel and into the base track. Screw fix end and base track junction with 10 g x 16 mm Type 'D' drill point wafer head screws
- Fix PartiWall end track to steel frame with PartiWall aluminium clip



Step 3: Install First PartiWall Stud and Clip

- Fit PartiWall stud fully down into the PartiWall base track and move tight over the edge of Shaftliner MouldStop panel. Tap lightly to give a snug fit
- Fit second Shaftliner MouldStop panel into PartiWall base track and push tight into the PartiWall stud
- Fix PartiWall stud to steel frame top plate with PartiWall aluminium clip

INSTALLATION OF SHAFTLINER MOULDSTOP FIRE BARRIER CONT.



Step 4: Continue Installing Shaftliner MouldStop Panels and PartiWall Studs

- Continue to install Shaftliner MouldStop panels and PartiWall studs until reaching end of wall
- As framing progresses, fix PartiWall studs to steel framing with PartiWall aluminium clips
- Cut the last Shaftliner MouldStop panel in line with the end of PartiWall base track. Fit PartiWall end track tightly over the edge of the panel and screw fix end and base tracks junction with 10 g x 16 mm drill point wafer head screws both sides
- Fix end track to steel frame with PartiWall aluminium clip



Step 5: Seal Base Track

- Apply continuous Firesound sealant along PartiWall base track/floor junction on one side only



Step 6: At Mid-Floors

- Screw laminate 16 mm FireStop to one side of Shaftliner MouldStop fire barrier with 10 g x 40 mm Type 'L' laminating screws at max 400 mm centres (both directions) and nom 10 mm from the edges. Ensure minimum 150 mm overlap above floor and below ceiling level. Plasterboard joints do not need to be set with compounds. Ensure joints are tight. Butt joints must fall centrally between PartiWall studs
- Screw fix PartiWall aluminium clips through 16 mm FireStop into PartiWall studs and end tracks and fix PartiWall aluminium clips to steel frame



Step 7: Install top track

- Using full track lengths, fit PartiWall top track over the installed Shaftliner MouldStop panels and PartiWall studs.
- Push top track fully down over the top of PartiWall studs.
- Screw fix top and end track junctions with 10 g x 16 mm Type 'D' drill point wafer head screws.

INSTALLATION OF SHAFTLINER MOULDSTOP FIRE BARRIER CONT.



Step 8: Next level of Shaftliner MouldStop Fire Barrier

- Using full track lengths, install PartiWall bottom track for the upper level of Shaftliner MouldStop fire barrier back-to-back with the top track below and leaving 6 mm gap between track lengths. Screw fix each track length with 10 g x 16 mm Type 'D' drill point wafer head screws at 600 mm maximum centres and at each end
- Install Shaftliner MouldStop panels, PartiWall studs and clips as per level below. PartiWall studs must align with studs below. If PartiWall studs are not aligned with studs below, fix back-to-back tracks at max 300 mm centres

CONTINUOUS PARTIWALL® TRACKS FIXED BACK-TO-BACK WITH 10 G X 16 MM DRILL POINT WAFER HEAD TYPE 'D' SCREWS @600 MM CTRS.

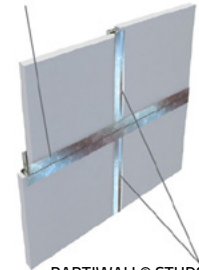

PARTIWALL® STUDS ON UPPER LEVELS MUST ALIGN WITH STUDS BELOW.

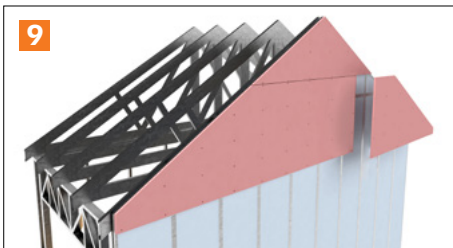

Step 9: At Roof

- Measure and cut Shaftliner MouldStop panels and PartiWall studs to pitch of roof
- Allow 25 mm gap at top of Shaftliner MouldStop panels for frame shrinkage and roof movement in pitched roof, flat metal roof, parapet and box gutter applications
- Fix PartiWall track on rake and fix PartiWall studs to roof frame on one side with PartiWall aluminium clips
- Screw fix top and end track junctions with 10 g x 16 mm Type 'D' drill point wafer head screws
- Screw-laminate 16 mm FireStop to one side of Shaftliner MouldStop with 10 g x 40 mm Type 'L' laminating screws at 400 mm max centres (both directions) and nom 10 mm from edges. Ensure minimum 150 mm overlap below ceiling level. Plasterboard joints do not need to be set with compounds. Ensure joints are tight. Butt joints must fall centrally between PartiWall studs
- Ensure minimum 150 mm overlap below ceiling level
- Screw fix PartiWall aluminium clips through 16 mm FireStop into PartiWall studs and end tracks and fix PartiWall aluminium clips to steel frame



Step 10: Seal for Fire

- Install continuous Knauf Firepack mineral fibre packer at external wall junctions and under roofing
- Fill cavities between roof battens with compressed mineral fibre packer

INSTALLATION DETAILS

Figure 9: Concrete Slab Base

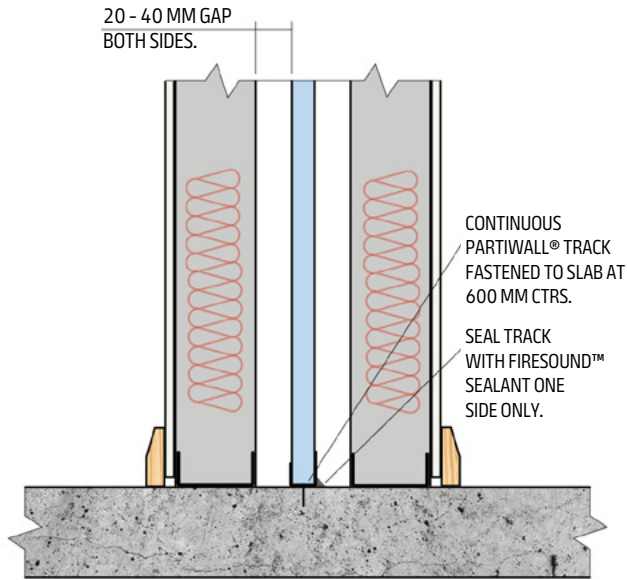

Notes The base track of the Shaftliner MouldStop fire barrier must be fixed with approved concrete fasteners spaced at 600 mm max ctrs. Plastic-sleeved fasteners are not permitted.

Figure 10: Masonry Base

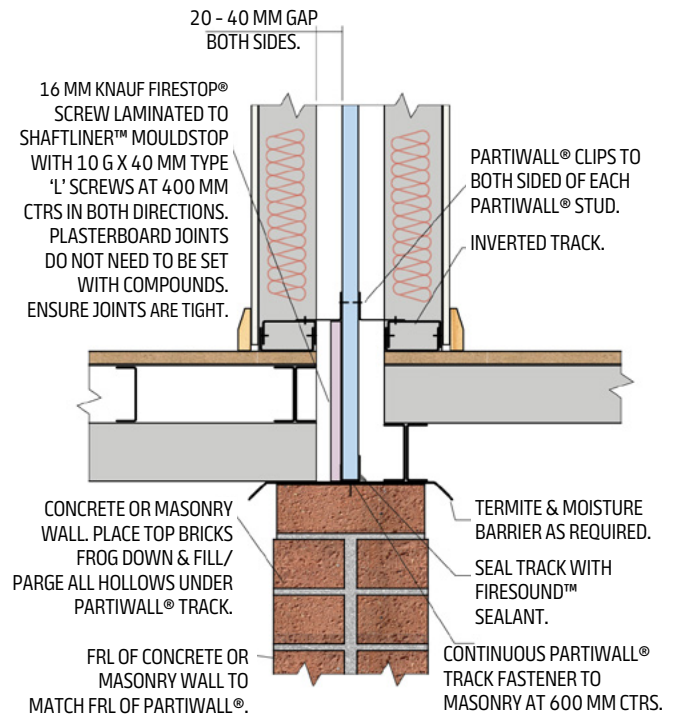

Figure 11: Step in Slab - Parallel 1

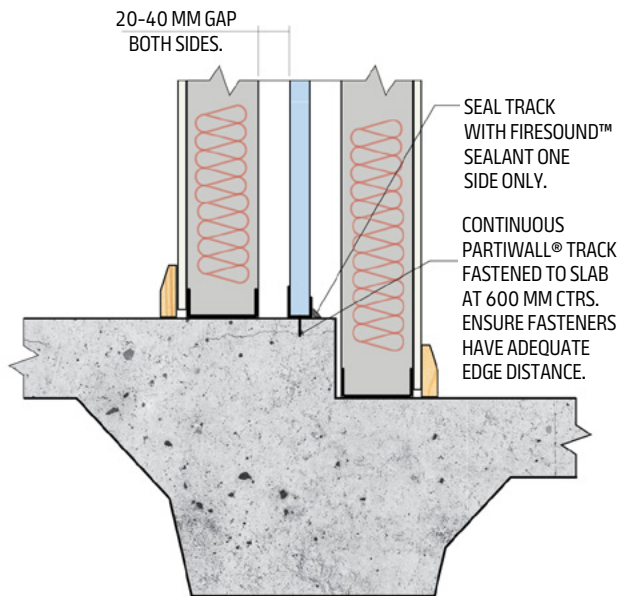
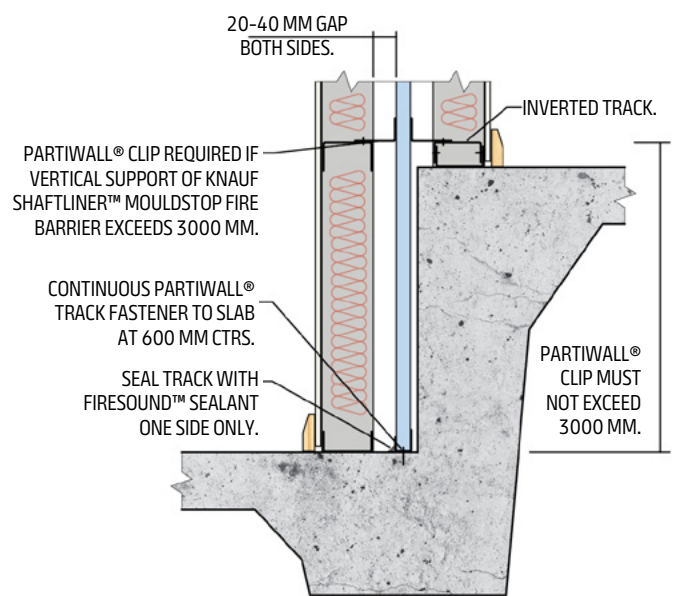

Figure 12: Step in Slab - Parallel 2



INSTALLATION DETAILS CONT.

Figure 16: Pitched Roof Junction

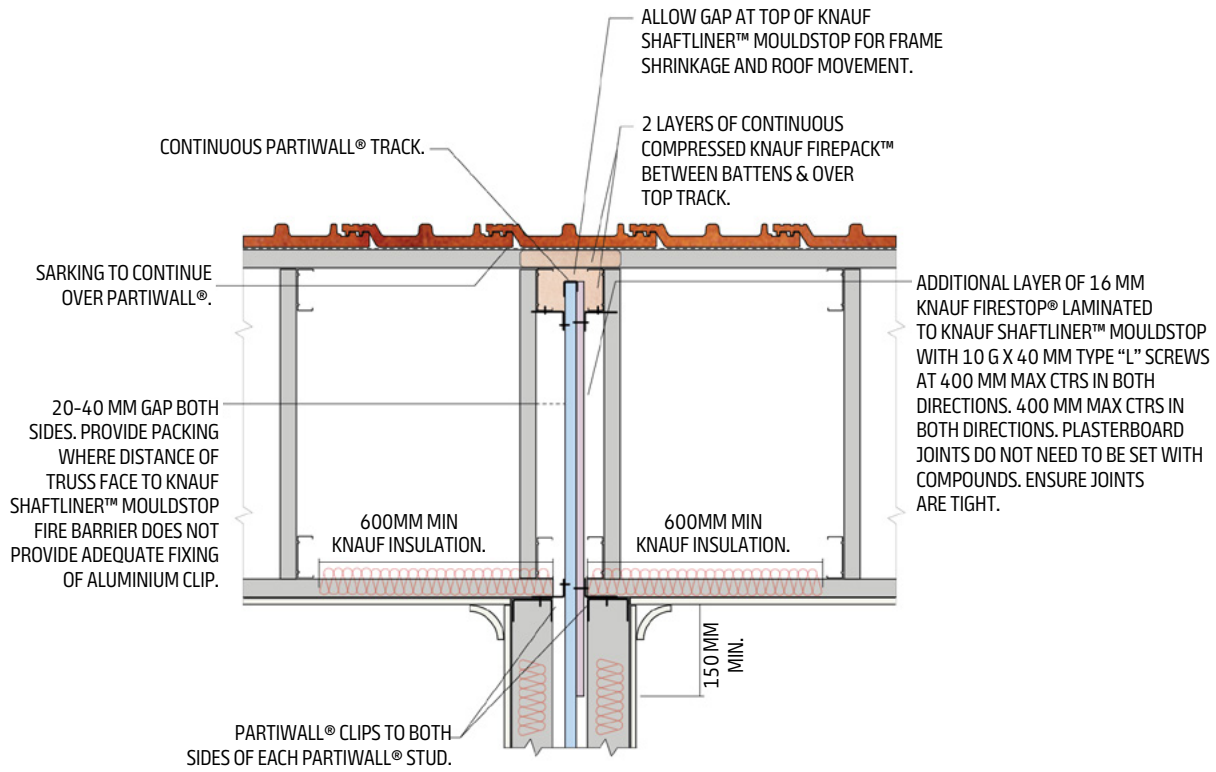
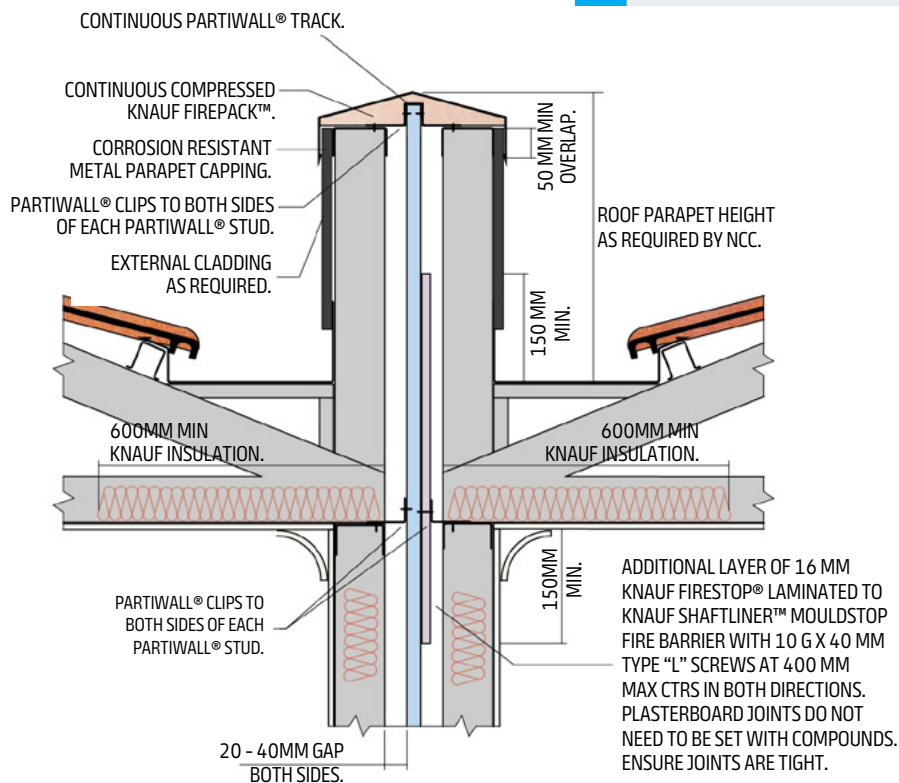

Figure 17: Parapet Roof Junction



Notes

- Ceiling insulation must extend min 600 mm both sides of the Partiwall and must satisfy thermal requirements.
- If no thermal insulation is required use insulation specified for Partiwall system.

INSTALLATION DETAILS CONT.

Figure 18: Flat Metal Roof

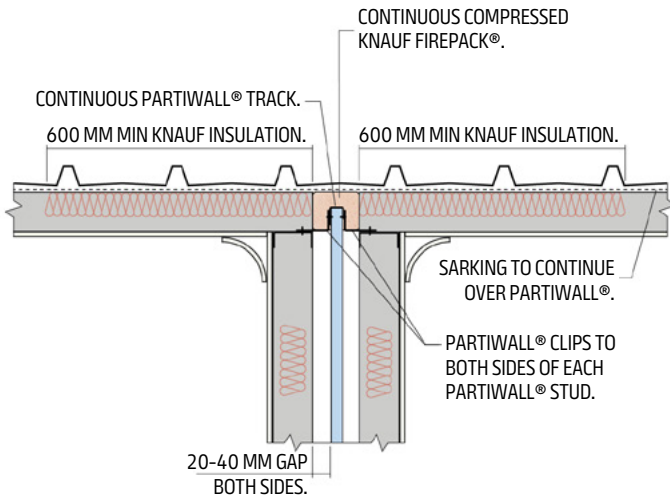

Notes

- Ceiling insulation must extend min 600 mm both sides of the PartIWall and must satisfy thermal requirements.
- If no thermal insulation is required use insulation specified for PartIWall system.

Figure 19: Roof Box Gutter

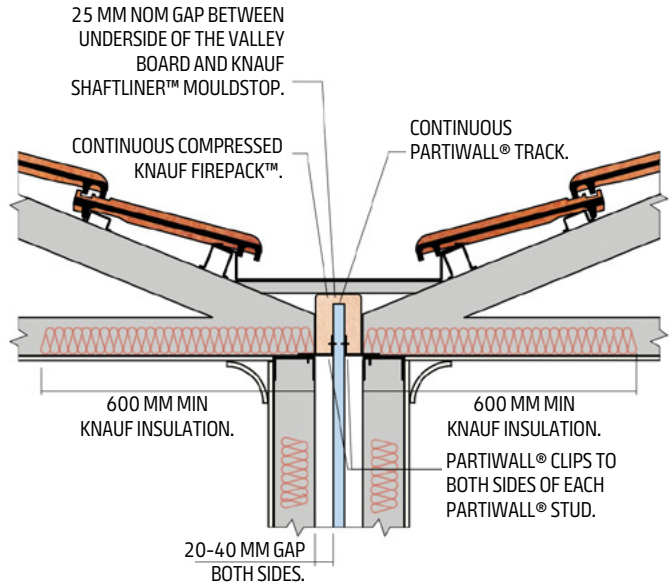

Figure 20: Staggered Metal Roof

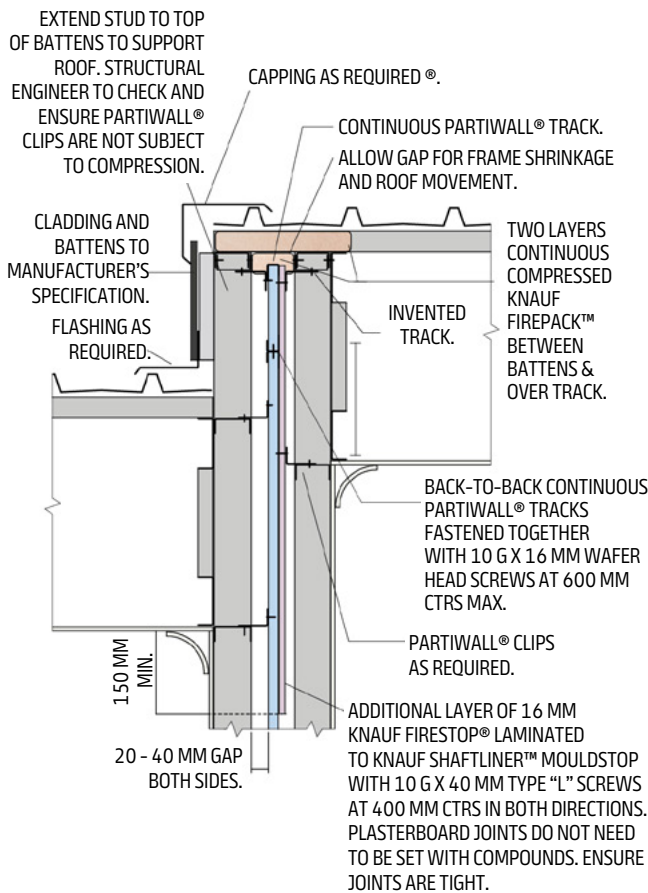
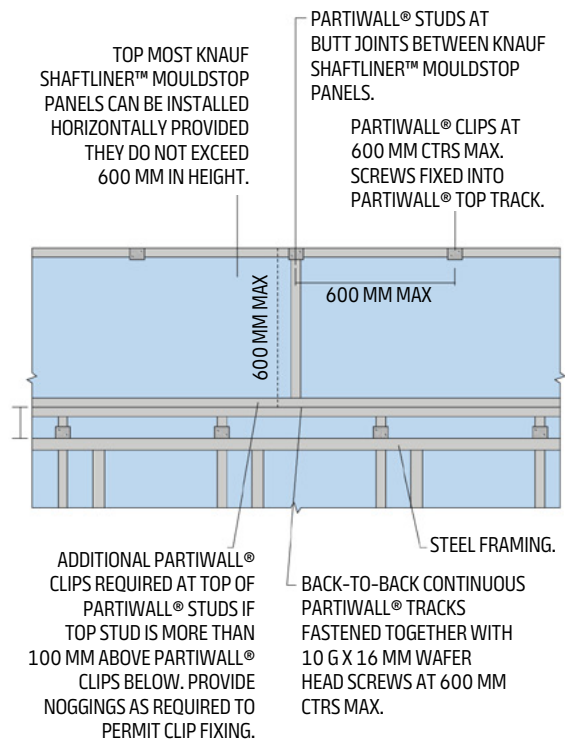

Figure 21: Horizontal Shaftliner MouldStop Under Roof



Notes

- 16 mm FireStop not shown for clarity.
- Refer to roof cross-sections for extent of additional layer of 16 mm FireStop in roof space.

INSTALLATION DETAILS CONT.

Figure 22: Rafter Closure – Section View

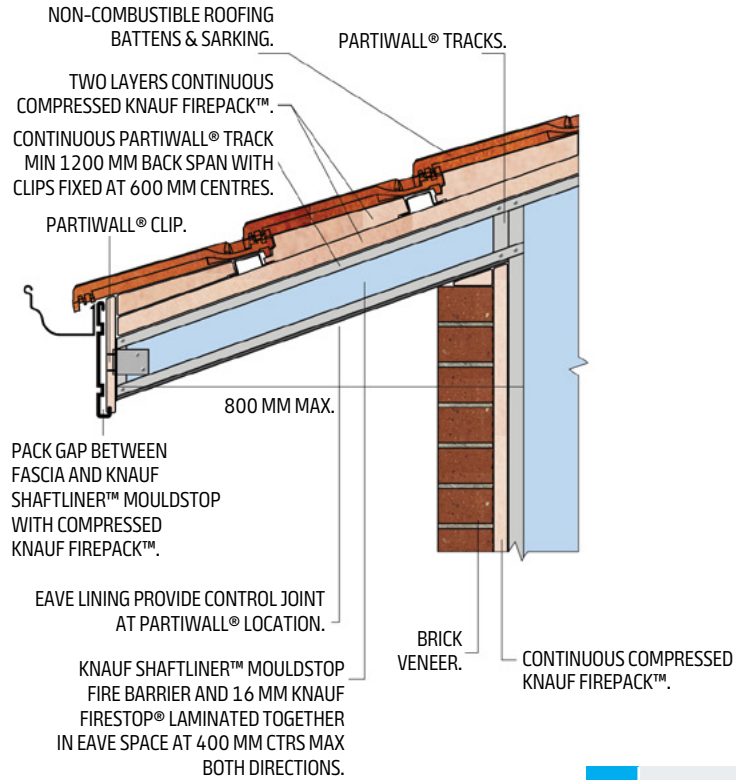
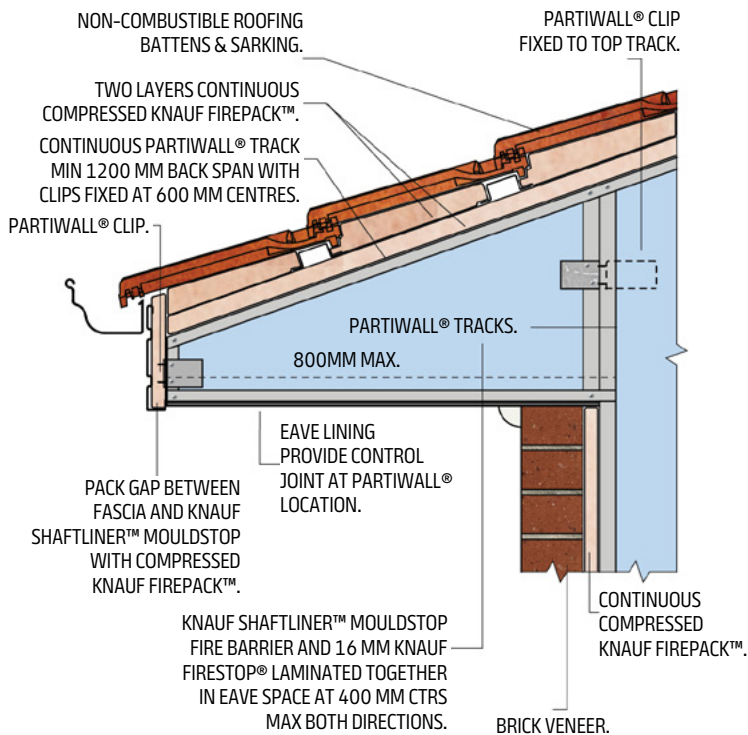

Figure 23: Eave Closure – Section View



Notes

- Laminated 16 mm FireStop not shown for clarity.
- Wall framing not shown for clarity.

INSTALLATION DETAILS CONT.

Figure 24: OutRwall Vertical Transition – JH Cladding

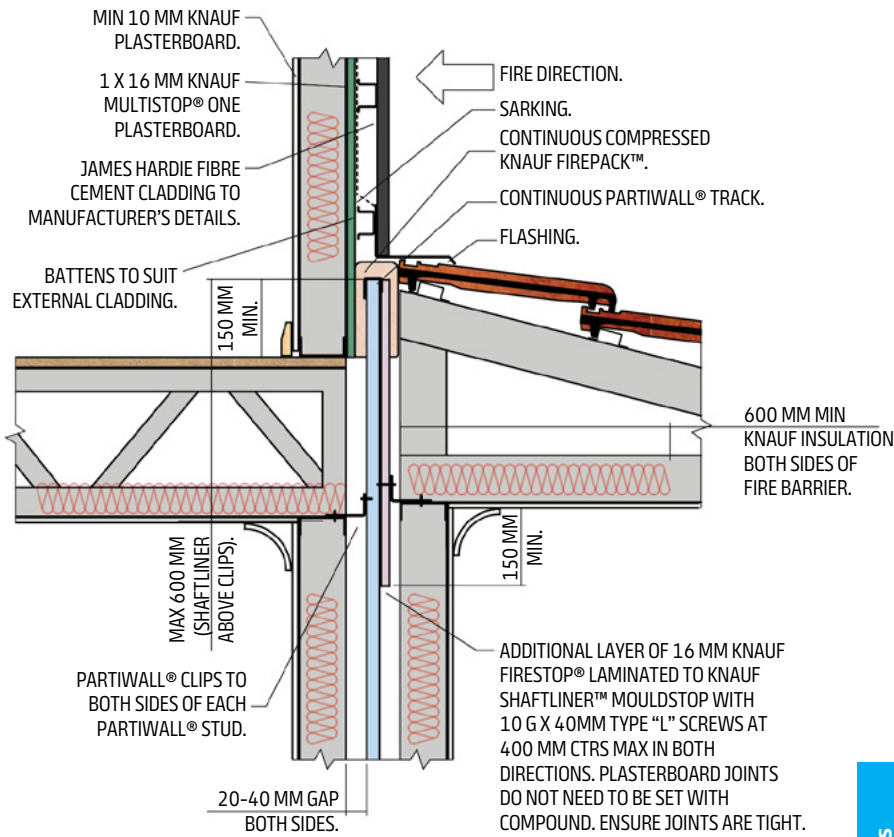
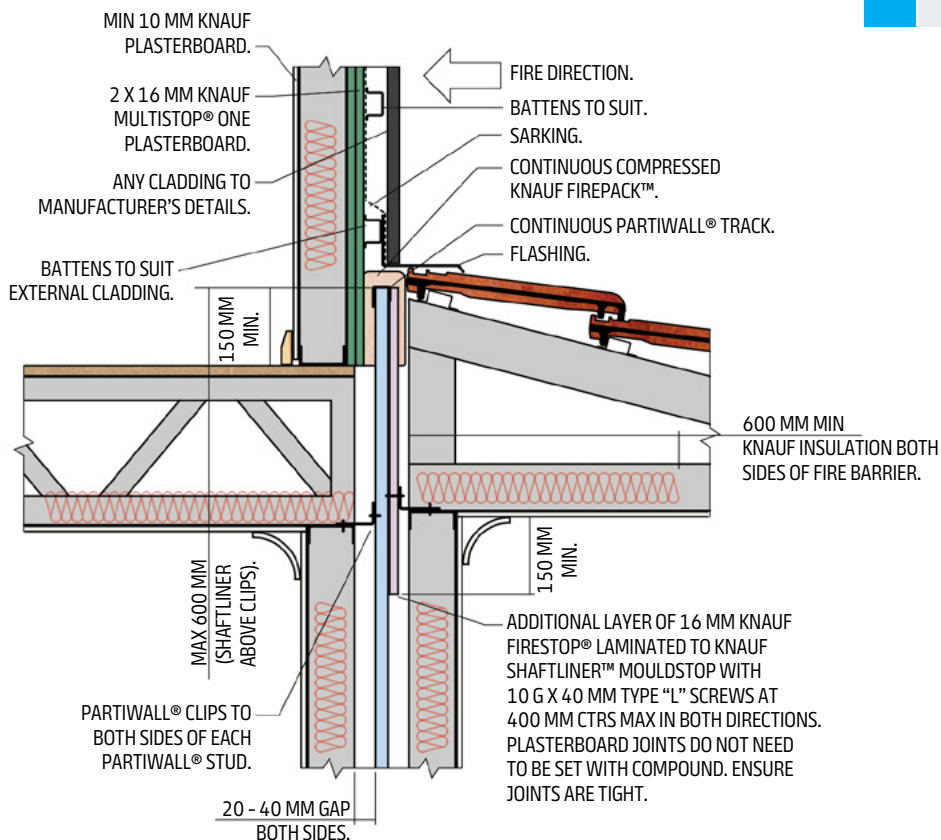

Figure 25: OutRwall Vertical Transition – Any Cladding



Notes

- For external wall transitions, Knauf OutRwall combined with James Hardie Fibre Cement residential cladding will result in a reduction from two layers to one layer of 16 mm FireStop on the external side to maintain FRL 60/60/60 from outside only.
- Refer Knauf for any load reduction requirements.

INSTALLATION DETAILS CONT.

Figure 26: OutRwall Vertical Transition – JH Cladding

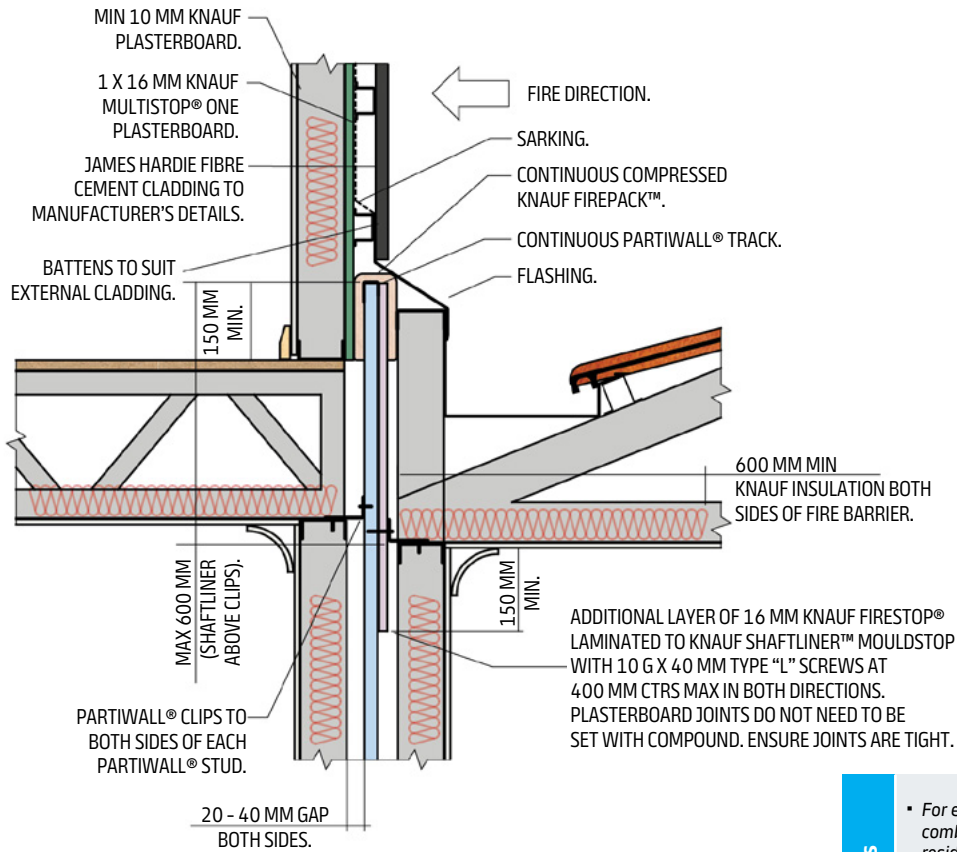
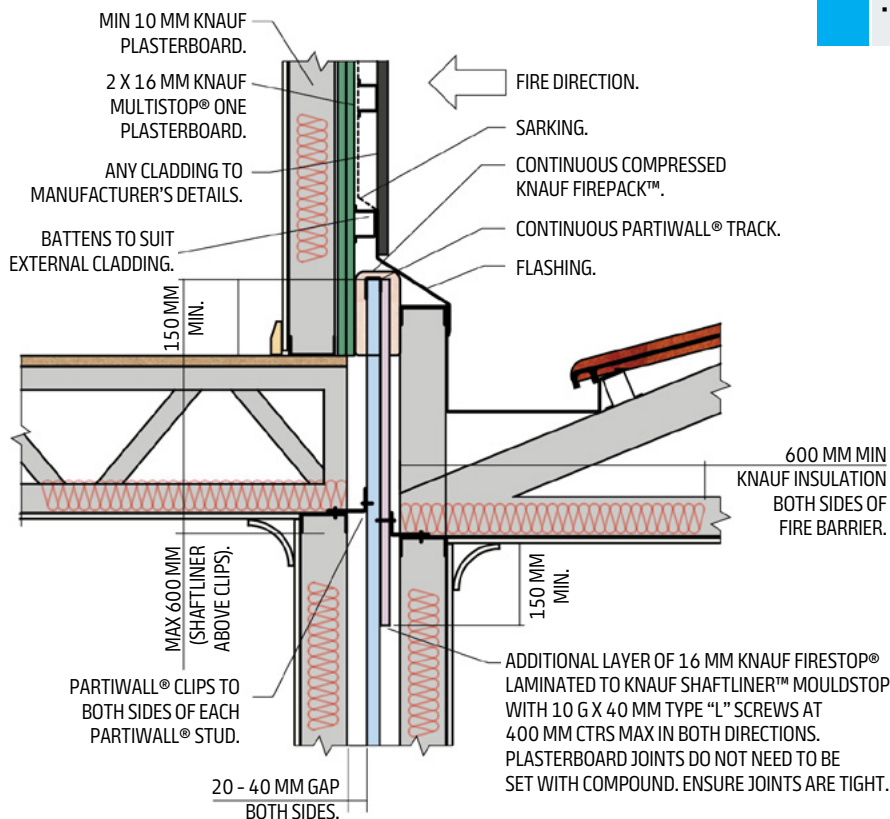

Figure 27: OutRwall Vertical Transition – Any Cladding



Notes

- For external wall transitions, Knauf OutRwall combined with James Hardie Fibre Cement residential cladding will result in a reduction from two layers to one layer of 16 mm FireStop on the external side to maintain FRL 60/60/60 from outside only.
- Refer Knauf for any load reduction requirements.

INSTALLATION DETAILS CONT.

Figure 28: Typical Corner – Plan View

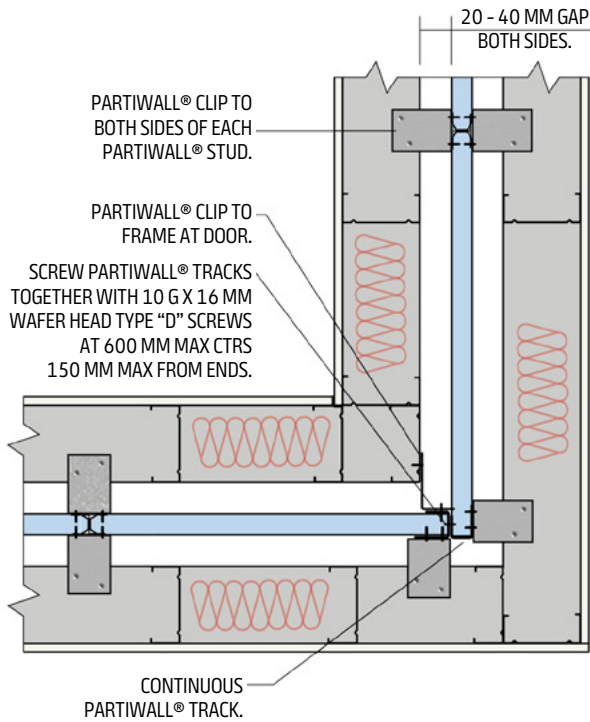

Figure 29: Internal Wall Junction – Plan View

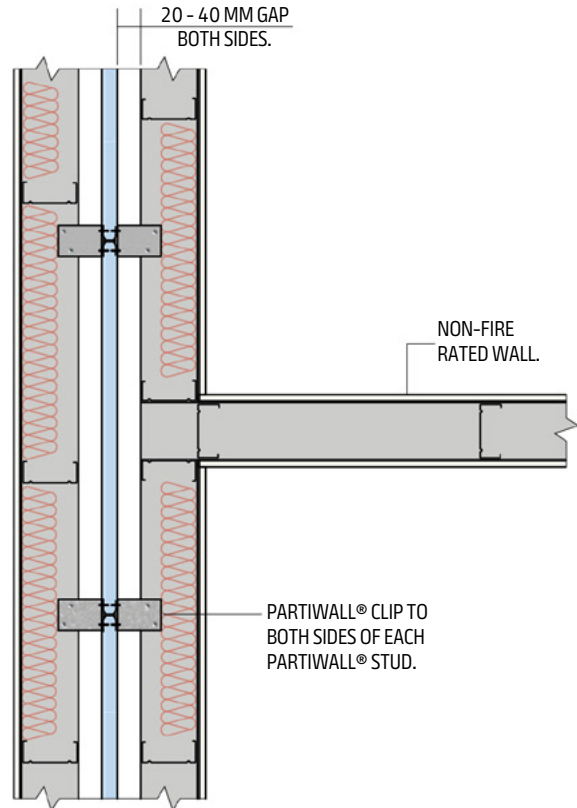

Figure 30: 4 Way Intersecting Wall – Plan View

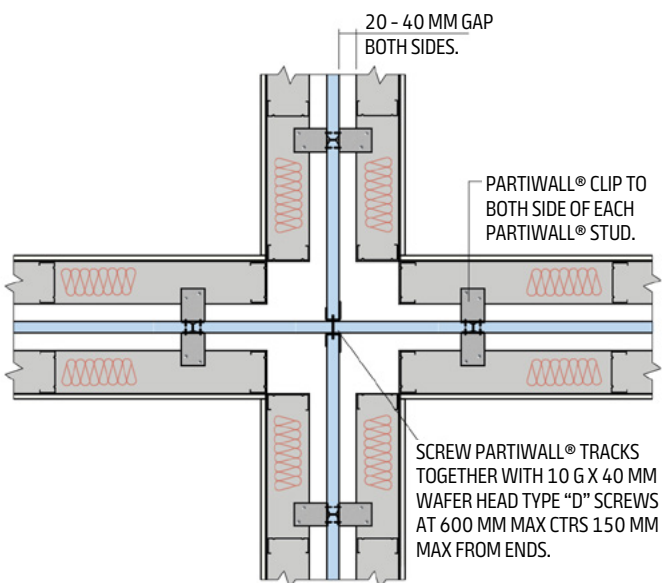
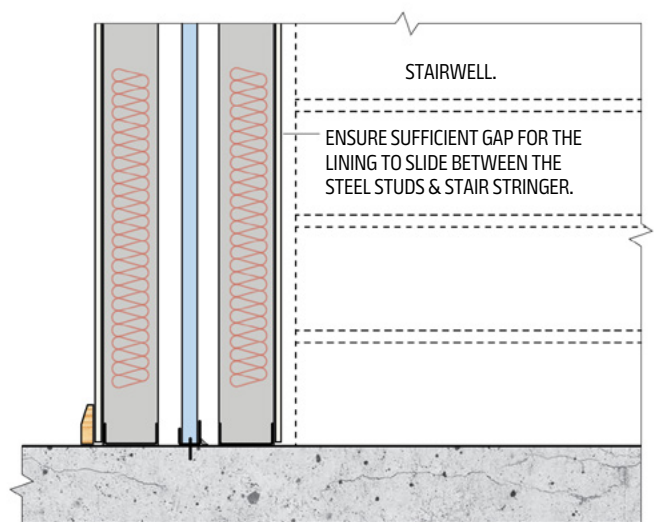
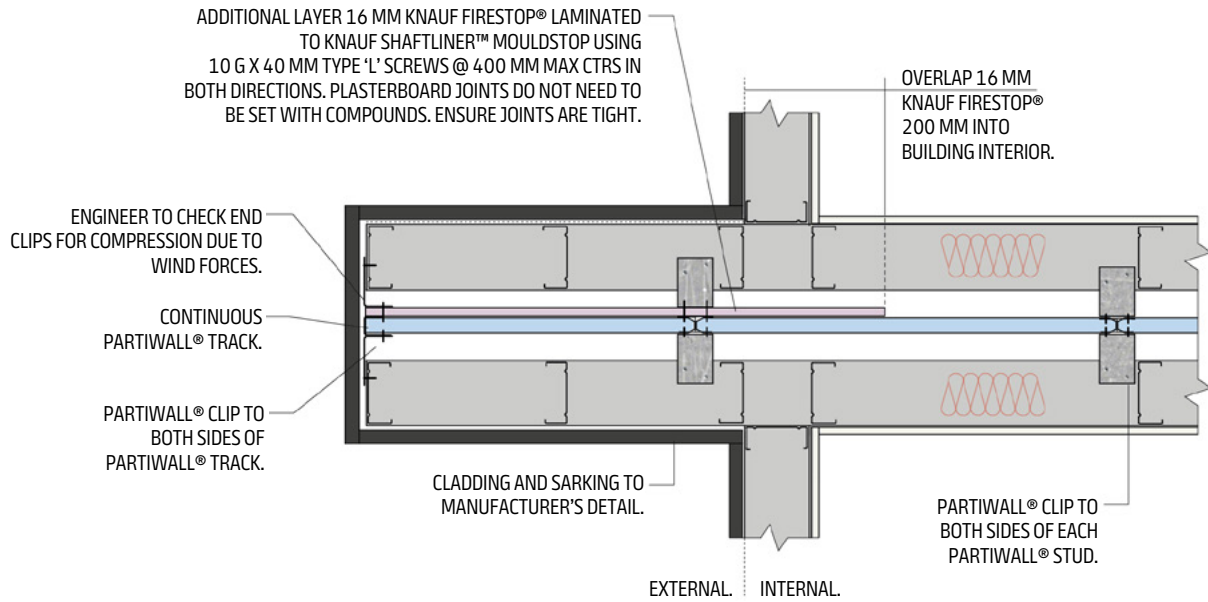

Figure 31: Adjacent Stairwell – Section View



INSTALLATION DETAILS CONT.

Figure 32: External to Internal PartiWall – Plan View



Notes
Aluminium flat clips can also be used to clip the PartiWall end.

Figure 33: OutRwall Horizontal Transition – JH Cladding

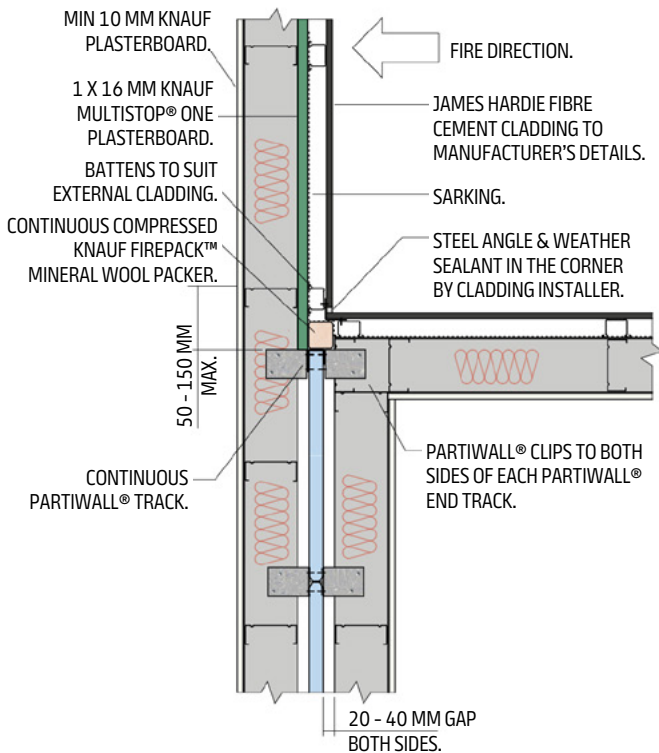
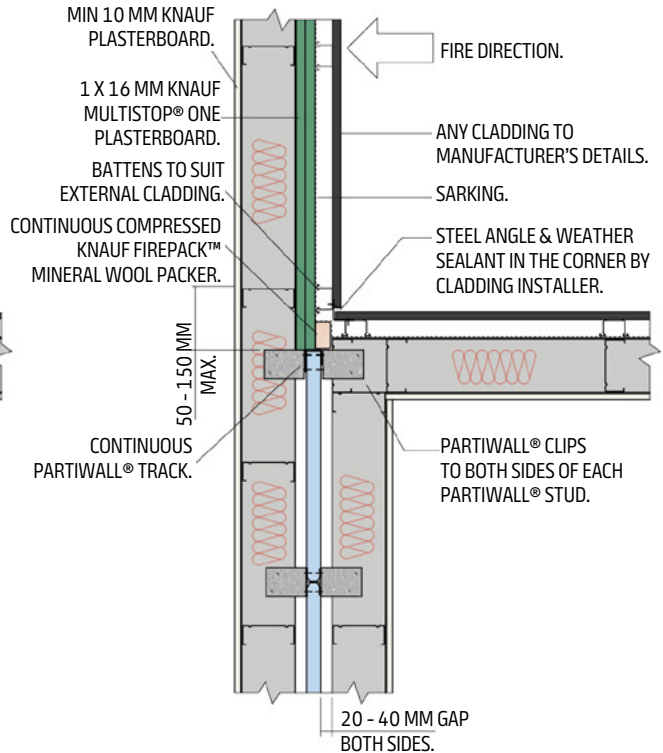

Figure 34: OutRwall Horizontal Transition – Any Cladding



Notes

- For external wall transitions, Knauf OutRwall combined with James Hardie Fibre Cement residential cladding will result in a reduction from two layers to one layer of 16 mm FireStop on the external side to maintain FRL 60/60/60 from outside only.
- Refer Knauf for any load reduction requirements.

INSTALLATION DETAILS CONT.

Figure 35: Clad Wall Junction – Plan View

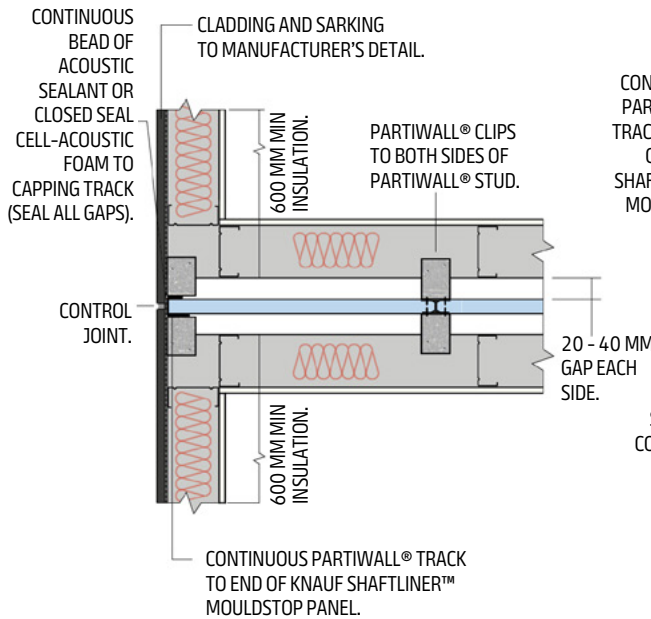
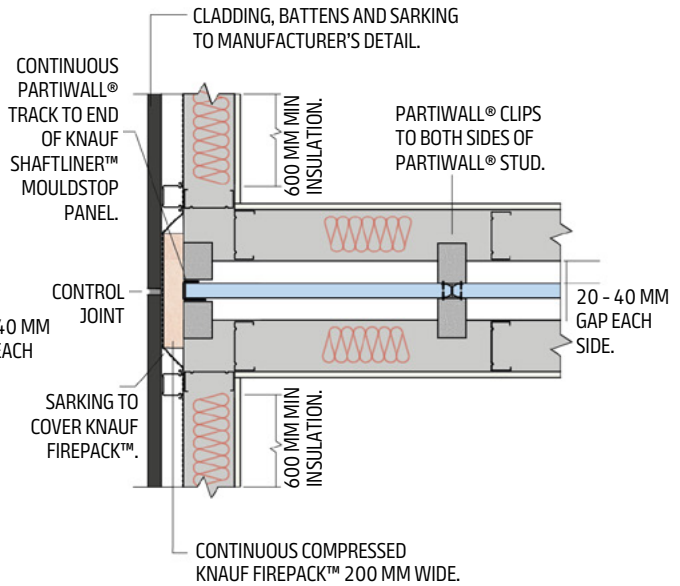

Figure 36: Clad Wall Junction with Thermal Break – Plan View



Notes

- For external wall transitions, Knauf OutRwall combined with James Hardie Fibre Cement residential cladding will result in a reduction from two layers to one layer of 16 mm FireStop on the external side to maintain FRL 60/60/60 from outside only.
- Refer Knauf for any load reduction requirements.

Figure 37: Brick Veneer Wall Junction 1 – Plan View

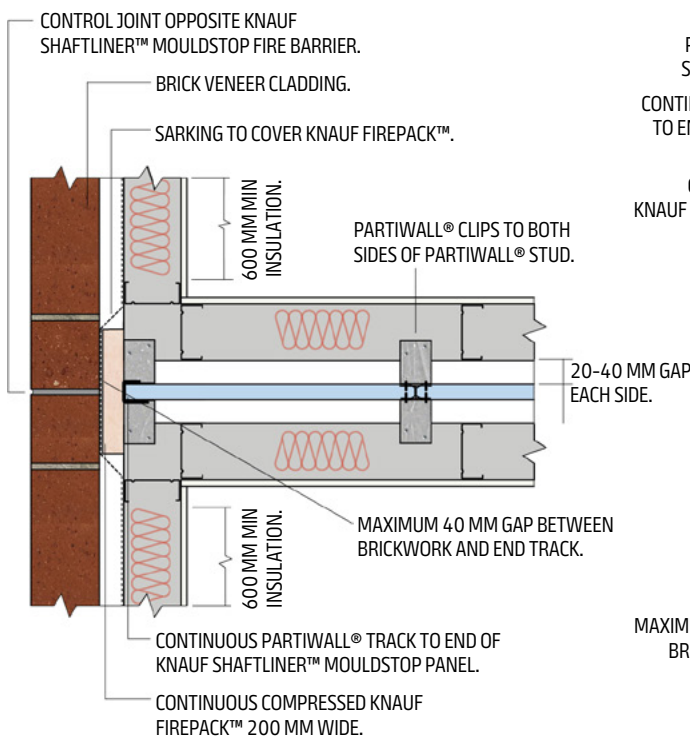
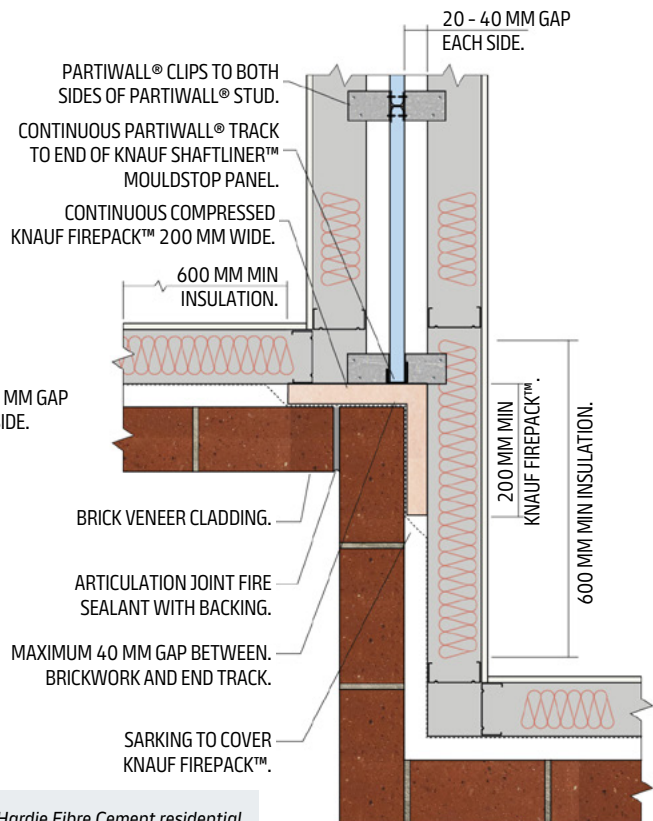

Figure 38: Brick Veneer Wall Junction 2 – Plan View



Notes

- For external wall transitions, Knauf OutRwall combined with James Hardie Fibre Cement residential cladding will result in a reduction from two layers to one layer of 16 mm FireStop on the external side to maintain FRL 60/60/60 from outside only.
- Refer Knauf for any load reduction requirements.

INSTALLATION DETAILS CONT.

Figure 39: Flat Aluminium Clip Detail

End Track

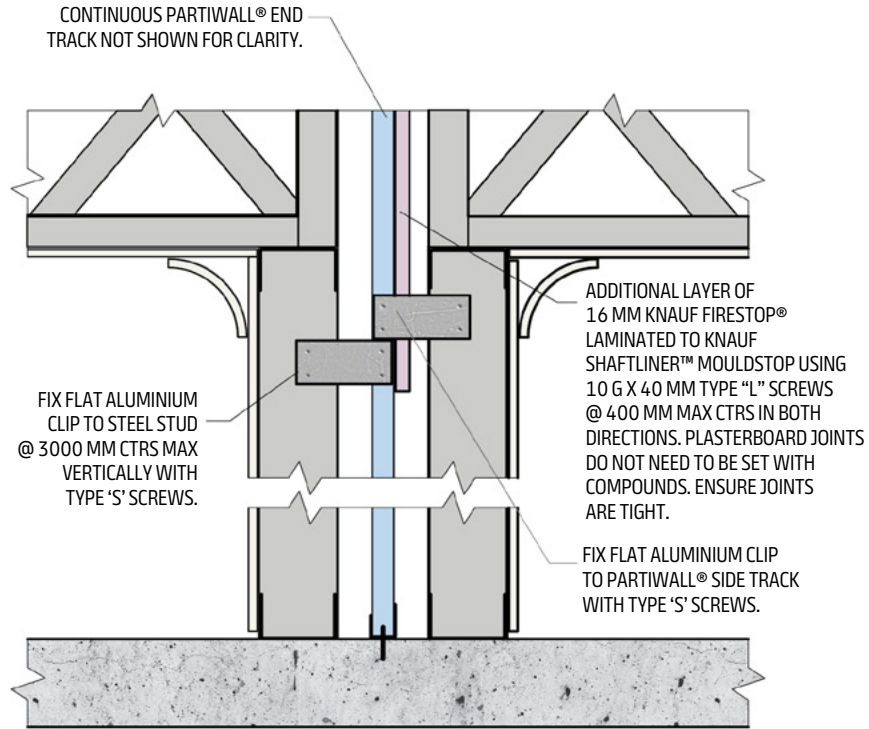

Top Track

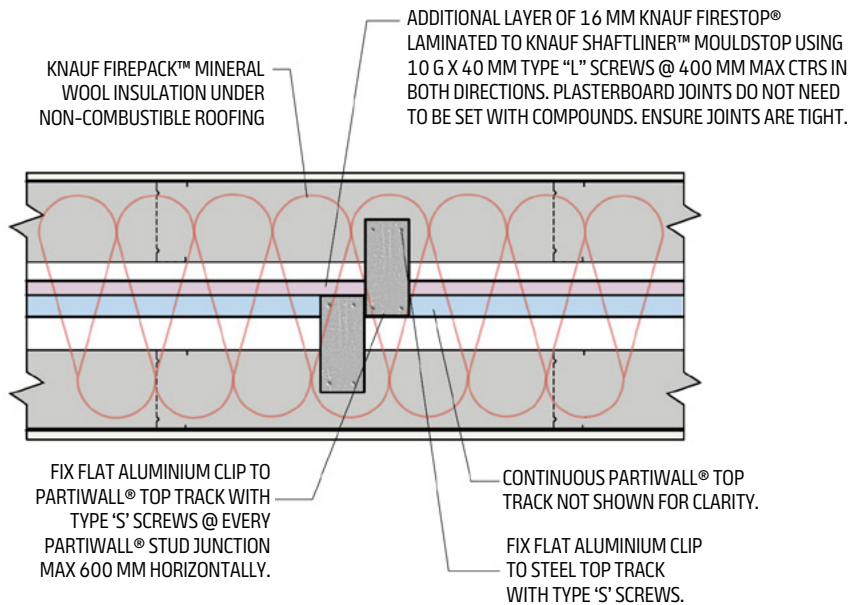

Notes

- PartiWall flat clips can be used around the perimeter of the fire barrier, spaced at max 3000 mm vertically on side tracks and 600 mm horizontally on top track.
- PartiWall angled clips cannot be flattened and used as flat clips.

INSTALLATION DETAILS CONT.

Figure 36: PartiWall Cantilever Details

Section View

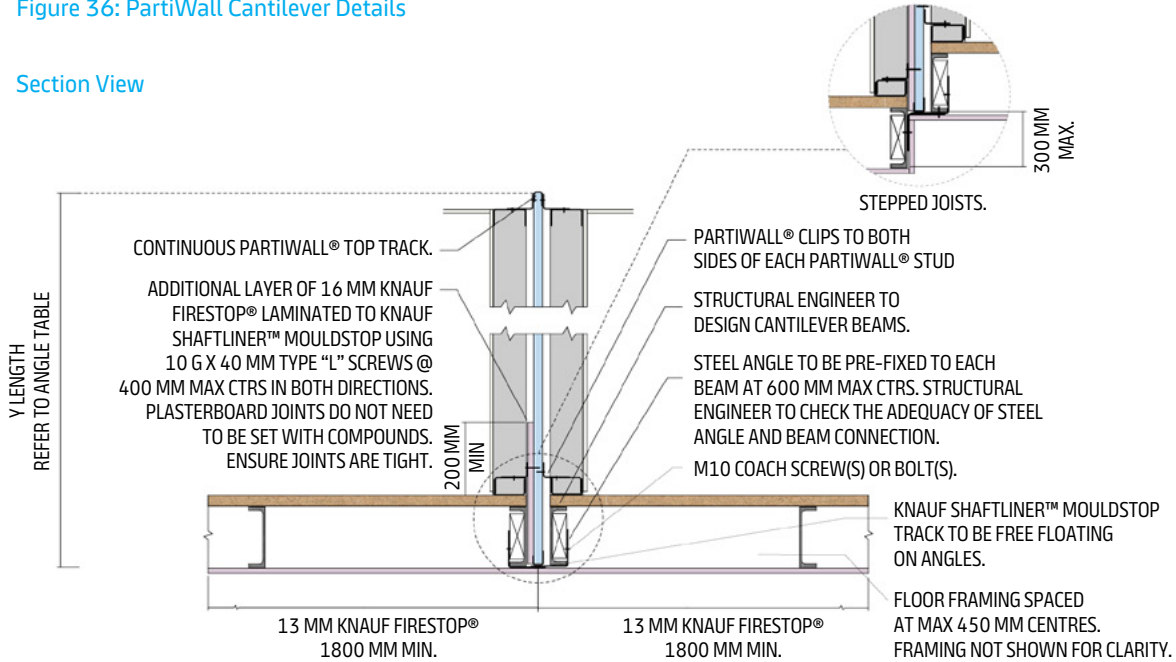

Plan View

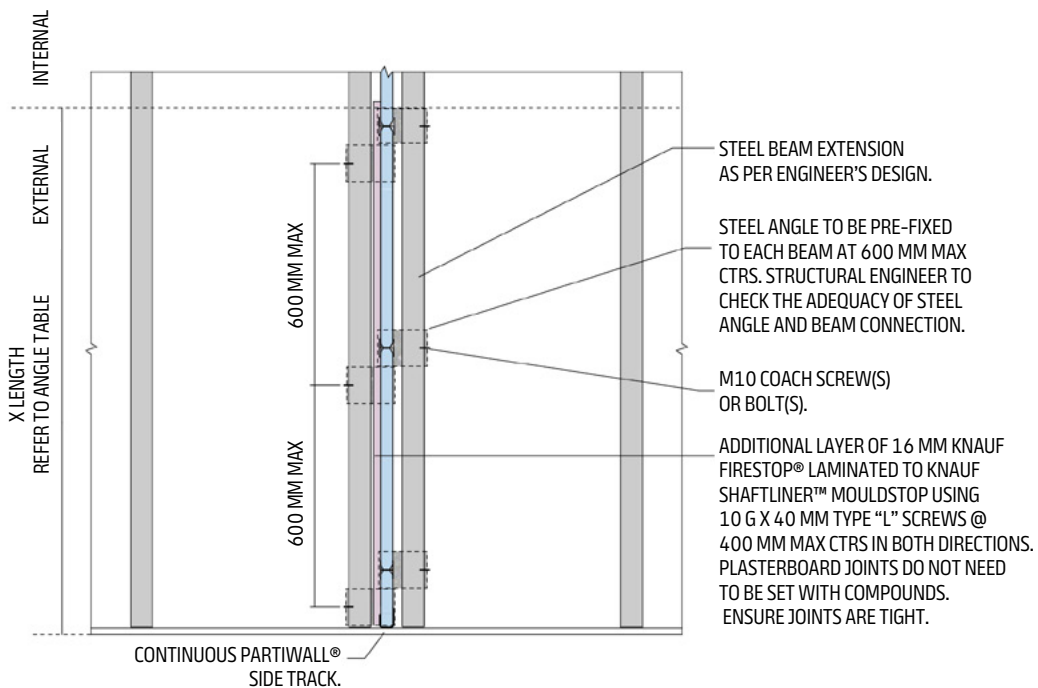

Steel Angle Requirements

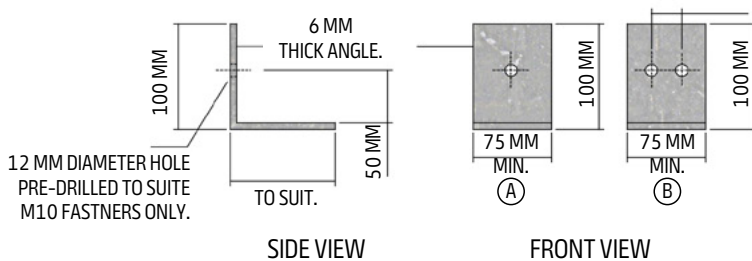

Angle Type Table

Cantilever [X] (mm)	Wall HT [Y] (mm)	Angle
<1500	<6000	A
<1500	<9000	B
1501-2000	<6000	B
1501-2000	<9000	B
2001-2500	<6000	B

Notes

- Steel angles can be either screwed, bolted or welded to the steel beam extension.
- Structural Engineer to check the adequacy of the steel beams, steel angles and beam connections.

INSTALLATION DETAILS CONT.

Figure 41: Back to Back Wall Penetrations – Plan Details – FRL 60/60/60

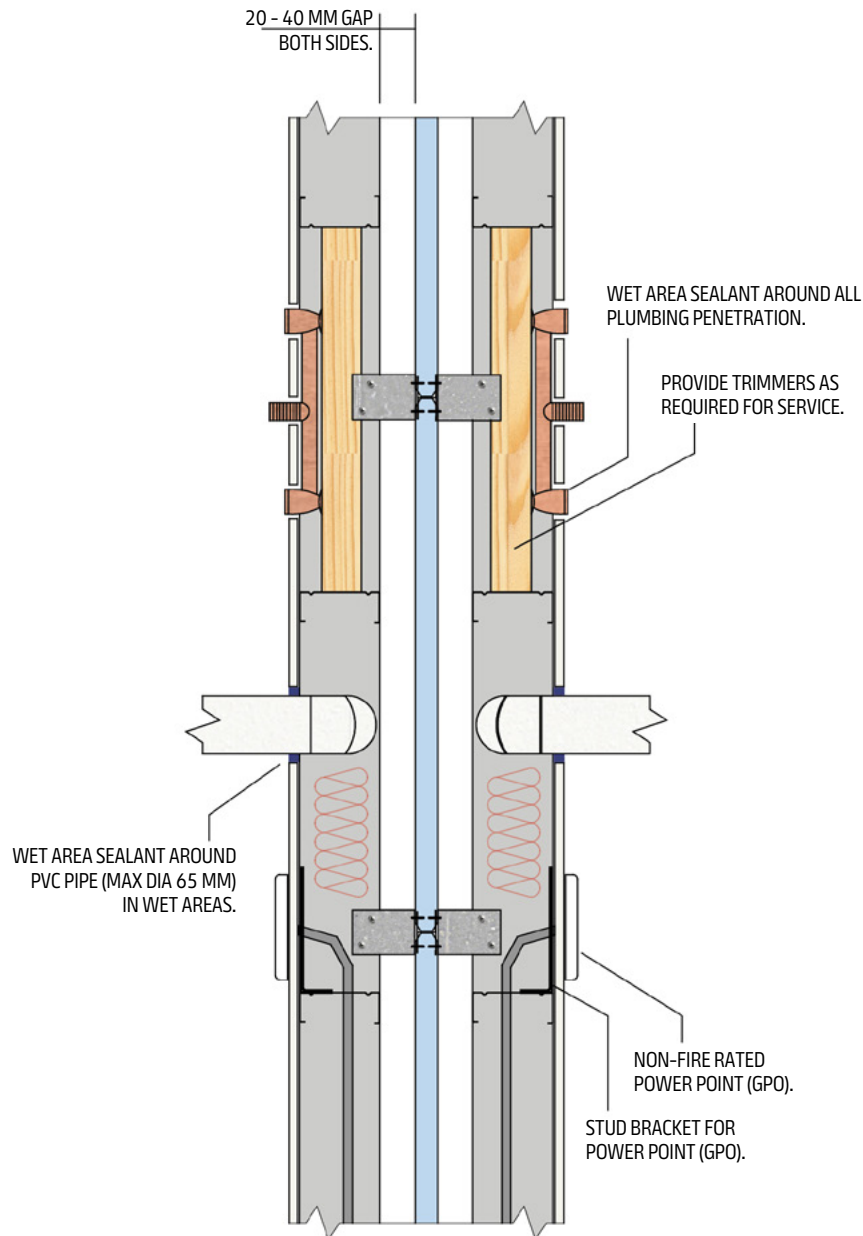

Notes

- All penetrations can be back-to-back.
- To achieve $R_w + C_{tr} 40$ services separation insulation is required in the wall cavity on the opposite side of the soil/waste/water supply pipe.

INSTALLATION DETAILS CONT.

Figure 42: uPVC Pipe Penetration at Roof Space – FRL -/60/60

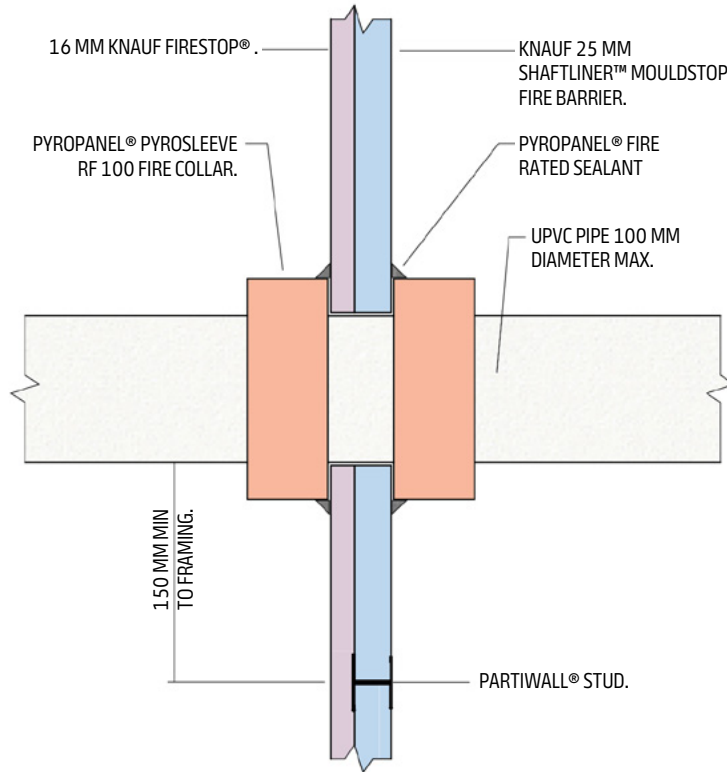
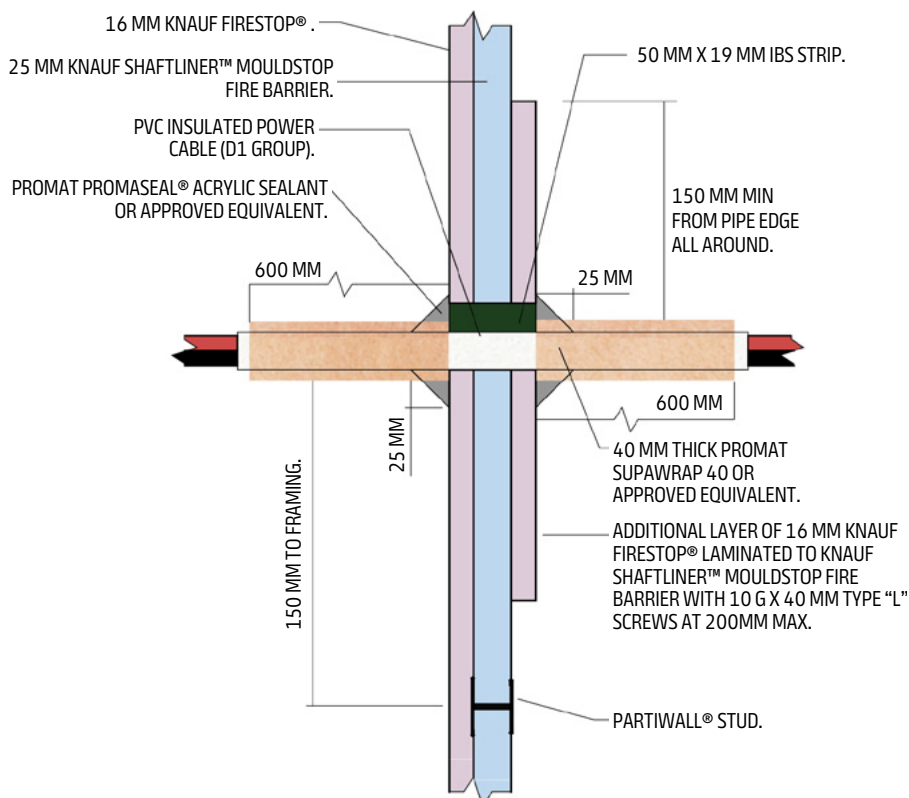
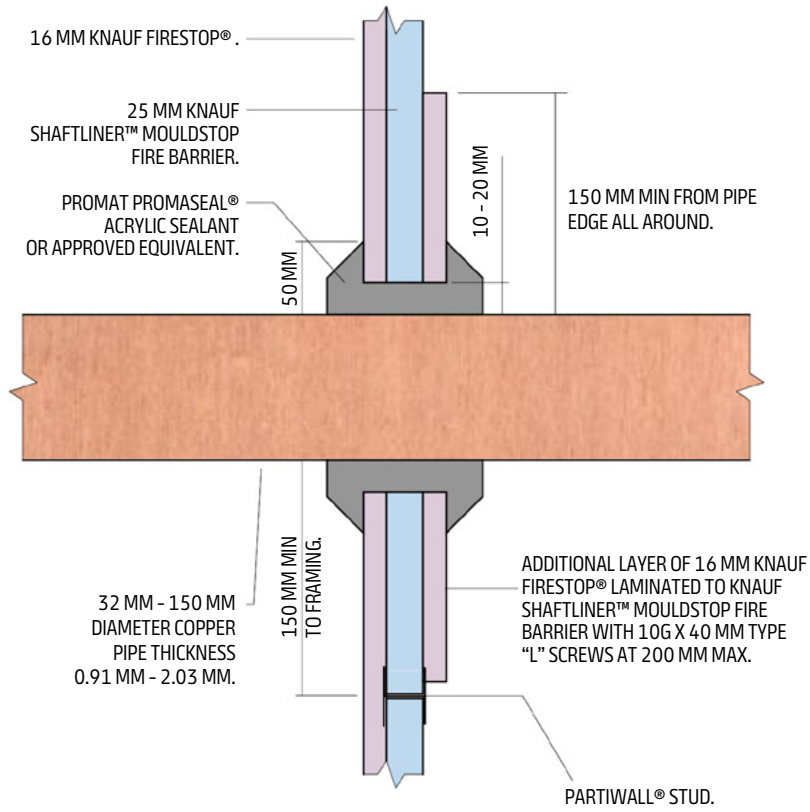

Figure 43: Power Cable Penetration at Roof Space – FRL -/60/60



INSTALLATION DETAILS CONT.

Figure 44: Copper Pipe Penetrations at Roof Space – FRL –/60/–



Notes

Services penetrations through Shaftliner MouldStop fire barrier should be approved by Building Surveyor/Certifier prior to installation.

PARTIWALL CHECKLIST

Project Details			
Date	PartiWall Ref		
Suburb/Town	State	Postcode	
Builder	Installer		
Unit Number/Street			

Please tick the relevant box for each item:

Item	Confirmed	Rectification Required
Cavity between H-studs and frames on both sides is 20 mm–40 mm	<input type="checkbox"/>	<input type="checkbox"/>
PartiWall bottom tracks are fixed to the slab with approved all steel fasteners 150 mm maximum from each end and at 600 mm maximum centres	<input type="checkbox"/>	<input type="checkbox"/>
6 mm gap has been provided between adjacent PartiWall bottom tracks	<input type="checkbox"/>	<input type="checkbox"/>
Firesound sealant has been applied along the PartiWall bottom track at least on one side (NOT underneath)	<input type="checkbox"/>	<input type="checkbox"/>
PartiWall tracks have been fitted to Shaftliner MouldStop panels around perimeter and screw fixed to PartiWall top and bottom tracks at each level	<input type="checkbox"/>	<input type="checkbox"/>
PartiWall studs (not Shaftliner MouldStop panels) are attached to framing on both sides with PartiWall aluminium clips at maximum 3000 mm vertically and 600 mm horizontally	<input type="checkbox"/>	<input type="checkbox"/>
PartiWall studs in roof cavity are attached to roof framing with PartiWall aluminium clips as indicated in PartiWall Guide	<input type="checkbox"/>	<input type="checkbox"/>
PartiWall studs on upper levels are aligned with PartiWall studs below	<input type="checkbox"/>	<input type="checkbox"/>
PartiWall eave details have been constructed in accordance with PartiWall Guide	<input type="checkbox"/>	<input type="checkbox"/>
Back-to-back PartiWall tracks (NOT PartiWall H-studs) are installed at horizontal joints between Shaftliner MouldStop panels	<input type="checkbox"/>	<input type="checkbox"/>
There are no penetrations through Shaftliner MouldStop panels apart from any approved penetrations in the roof space	<input type="checkbox"/>	<input type="checkbox"/>
No bridging occurs due to services between framing and Shaftliner MouldStop panels	<input type="checkbox"/>	<input type="checkbox"/>
Shaftliner MouldStop panels or other PartiWall components are not damaged	<input type="checkbox"/>	<input type="checkbox"/>
16 mm FireStop plasterboard is laminated to Shaftliner MouldStop panels at 400 mm centres in both directions at floor-ceiling junctions and in the roof space and butt joints to fall centrally between PartiWall studs	<input type="checkbox"/>	<input type="checkbox"/>
Compressed Firepack mineral wool packer has been installed between the top PartiWall track and roofing and between the end PartiWall tracks and external cladding	<input type="checkbox"/>	<input type="checkbox"/>
PartiWall system has been installed in accordance with installation specification and details contained in Knauf PartiWall Guide and any project specific instructions provided by Knauf	<input type="checkbox"/>	<input type="checkbox"/>

Builder's Supervisor	PartiWall Installer
Name	Name
Signature	Signature
Comments:	
<hr/> <hr/>	

BUILDING THE FUTURE TOGETHER.

The Knauf Group is one of the world's leading manufacturers of modern insulation materials, dry lining systems, plasters and accessories, thermal insulation composite systems, floor screed, floor systems, and construction equipment and tools. With more than 300 production facilities and sales organisations in over 90 countries, 42,000 employees worldwide, and sales of €12.6 billion, the Knauf Group is one of the largest players in the industry, with operations in Europe, the United States (US), South America, Asia, Africa, and Australia.

The Knauf Group believes that the best innovations start with a purpose; a focus on why the innovation is needed and who will benefit from it. The business's focus is to deliver innovations that help companies in the construction sector to work smarter, do more, and build better. This is achieved through investing in purposeful innovation, expanding into different markets and constantly searching for new ways to increase performance and productivity. This commitment to innovation and focus on customers is inspired by a desire to empower architects, contractors, and workers alike to improve the way societies live by changing the way buildings are designed and built. Knauf is committed to delivering only the best to its customers and partners.





Sales Enquiries

1800 003 377

To purchase Knauf plasterboard and other building materials including insulation, cornice, compounds, ceilings and accessories visit the Where To Buy page on our website for a list of Knauf Fulfilment Centres and distributors.

TecASSIST

1800 811 222

Our National TecASSIST helpline is available to answer technical questions and provide free advice to builders, contractors, architects, engineers and home owners throughout Australia.

Technical Resources

knauf.com/en-AU/tools/download-center

Find all of Knauf's technical literature in our comprehensive Download Centre. From CAD files to certifications, installation guides and data sheets - our most up to date product and system information is at your fingertips.



knauf.com

©2025 Knauf Gypsum Pty Ltd. All rights reserved. The trademarks Knauf, Build on us, TecASSIST, FireStop, Shaftliner, WetStop, ImpactStop and PartiWall are trademarks of Knauf Gypsum Pty Ltd or one or more of its affiliates, including Knauf Gips KG. SHEETROCK is a registered trademark of United States Gypsum Company and used under license. All other trademarks identified with ® or ™ are owned by third party manufacturers and not Knauf Gypsum.
Knauf Gypsum Pty Ltd. ABN 84 004 231 976. 3 Thackeray Street, Camellia NSW 2142, Australia.
30.09.2025_GVAU250822/09

**Build
on us.**