



© Copyright Kris Provoost, courtesy of Henning Larsen Architects

# **AQUAPANEL®**

# **EXTERIOR SYSTEMS**

Knauf Exterior Solutions with AQUAPANEL®  
Technology for Singapore and Malaysia.

**KNAUF**

## System introduction

AQUAPANEL® Exterior Systems are high-performance, economical and sustainable solutions for drylining style construction of exterior walls, claddings and ceilings.

AQUAPANEL® Exterior Wall comes in two basic types: drywall, or as a rear-ventilated rainscreen facade. It therefore offers an extremely flexible and adaptable solution, which can accommodate an impressive range of designs, helping to turn vision into reality.

From external soffits, underpasses or open and underground car parks to exterior ceilings, our solution is engineered to withstand the most challenging wet conditions.

## Outstanding protection against high humidity and moisture

The systems are the perfect solutions for exterior walls, claddings, and ceilings exposed to moisture, wind loading, and coastal environments. The components are designed and tested to achieve the highest performance in construction.

AQUAPANEL® Cement Board Outdoor is water-resistant and made of inorganic materials, which prevents mildew from forming and spreading.

The steel framing system, designed to support AQUAPANEL® Cement Board Outdoor is supplied by Rondo, with components coated with Zinc Z275/Z450, making it suitable for a variety of exterior systems (refer to Rondo for details).

## Options for external finishes

Different external renders can be specified as a finish coat, offering options for texture and colors. The system can also accommodate other materials, such as tiles.

## Complete Knauf engineered solution backed by industry experts

Our team of engineers and specification managers will provide you with support throughout the project; from conceptual design, to reviewing architectural drawings and site support to ensure optimum performance in design and construction.



*AQUAPANEL® Exterior Systems deliver creativity and certainty from seaside and hospitality projects through to commercial and residential buildings.*

*Markor Cave | Beijing, China*

# EXTERIOR WALL, CLADDINGS AND CEILINGS

## Benefits

- Simple installation
- Easy to cut, score, and snap
- No pre-drilling for fasteners
- Resistant to moisture and driving rain
- Mold and mildew-resistant
- Dimensionally stable, robust and durable
- Non-combustible (A1): complies with European standards
- Creative design opportunities
  - > Options for the creation of curved exterior walls, claddings and ceilings
  - > Spectacular seamless surfaces, thanks to expansion joints that are only needed every 15 m to enable a 225 m<sup>2</sup> closed area without a visible joint\*
- Large choice of colours, textures, and finishes with different external render systems

With Knauf AQUAPANEL® Exterior Systems, the exterior walls, claddings and ceilings are optimally protected against various types of weather effects, regardless of their location.

\*A control/movement joint must be installed if there is a control/movement joint in the structure underneath.



*Eagle in Flight | Tirana, Albania*

Physical properties - AQUAPANEL® Cement Board Outdoor	
Length (mm)	2,400/2,440
Width (mm)	1,200/1,220
Depth (mm)	12.5
Min. bending radius for 1,200 mm wide board (m)	3
Min. bending radius for 300 mm wide strip (m)	1
Weight (kg/m <sup>2</sup> )	approx. 16
Dry bulk density (kg/m <sup>3</sup> ) according to EN 12467	approx. 1,150
Bending strength (MPa) according to EN 12467	≥ 7
Tensile strength perpendicular to the plane of the board (N/mm <sup>2</sup> ) according to EN 319	0.65
Shearing strength (N) according to EN 520	607
pH-value	12
Thermal conductivity (W/mK) according to EN ISO 10456	0.35
Thermal expansion (10 <sup>-6</sup> K <sup>-1</sup> )	7
Water vapour diffusion coefficient μ (-) according to EN ISO 12572	66
Length variation 65% - 85% humidity (mm/m) according to EN 318	0.23
Thickness variation 65% - 85% humidity (%) according to EN 318	0.2
Building material class according to EN 13501	A1 non-combustible
Certificate of conformity (COC) according to BS 476-4:1970 (Singapore)	non-combustible
Fungus Resistance according to ASTM D3273-16	Rating 10 (0 defacement by mold growth)
Fungus Resistance according to ASTM G21-15	Rating 0 (No fungal growth)

## New design possibilities for curved walls

With a bending radius of 3 metres (full board) and 1 m (300 mm strips), AQUAPANEL® Cement Board Outdoor allows designers to introduce a variety of curved shapes and creative designs, including domes and arches. Moreover, by using double studs, it's possible to create different interiors and exteriors: for example, a wall that's concave on the outside, and convex on the inside.



Lingang Warehouse | Shanghai, China

## Arrangement of AQUAPANEL® Cement Board Outdoor with different radius

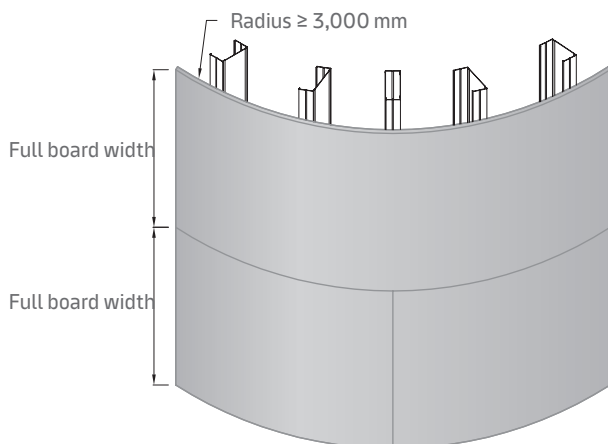

Assembly with full board size panels for radius  $\geq 3,000$  mm

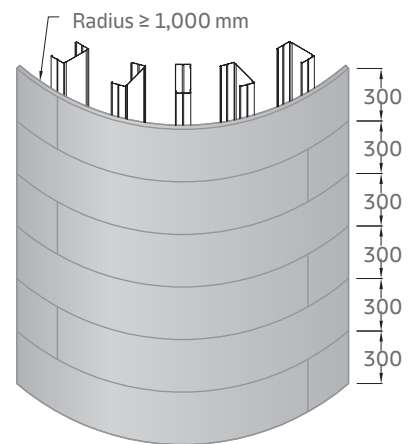

Assembly with 300 mm width panels for radius  $\geq 1,000$  mm

# DEDICATED SYSTEM SOLUTIONS



## AQUAPANEL® Exterior Wall – rear-ventilated rainscreen facade

With rainscreen facades for use above solid substructures, such as brick or concrete, thermal insulation is separated from the weather protection materials ensuring a constant flow of air in the ventilated space to remove moisture from the building and to optimise indoor climate. Even if the facade is damaged, the insulation remains intact.

## AQUAPANEL® Exterior Wall – drywall solution

Drywall systems are available as single stud solutions with a variety of creative design options. And although it is most commonly used in skeleton constructions comprising reinforced concrete, drywall is also suitable for timber or lightweight steel-frame constructions.

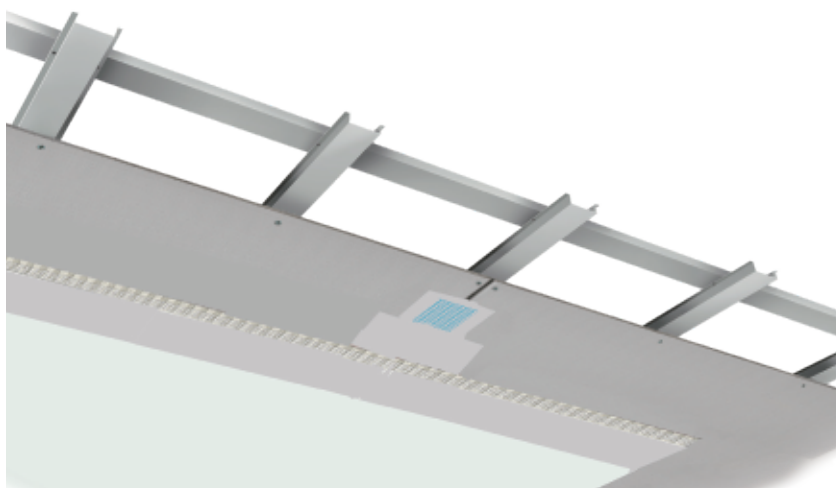
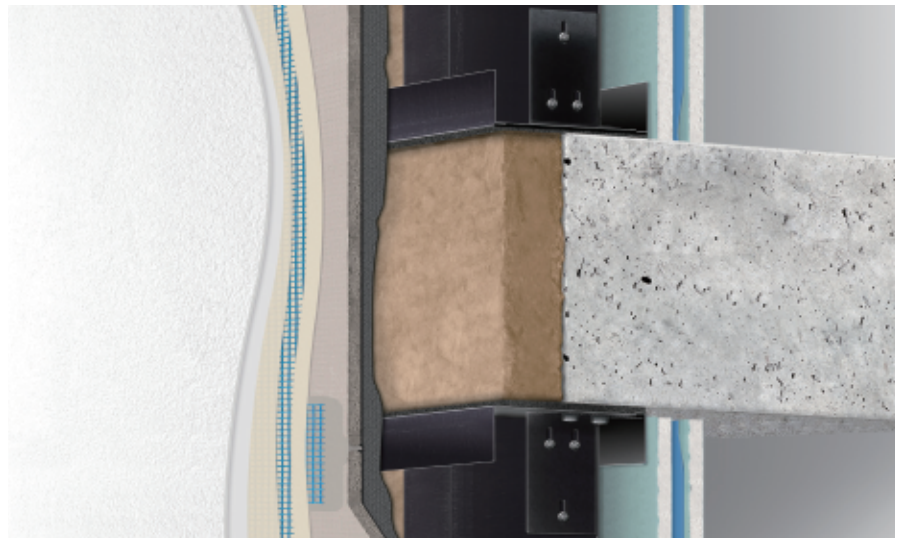

## AQUAPANEL® Exterior Ceiling

Ideal drylining solution for exterior ceilings, such as soffits, undersides of balconies, underpasses, and underground car parks with proven resistance to moisture or mildew forming and spreading. For greater safety and the highest standards in design, construction, cost-effectiveness, and durability.

### WL132C.1 Rear-ventilated rainscreen facade

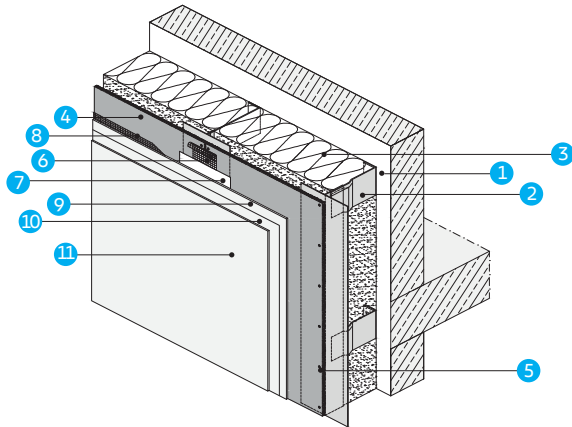

- 1 Optional Thermal separation element
- 2 RONDO Cladding System
- 3 Insulation board according to local needs
- 4 AQUAPANEL® Cement Board Outdoor
- 5 AQUAPANEL® Maxi Screw
- 6 AQUAPANEL® Joint Tape (10 cm)
- 7 AQUAPANEL® Joint Filler – grey
- 8 AQUAPANEL® Reinforcing Mesh
- 9 AQUAPANEL® Exterior Basecoat
- 10 AQUAPANEL® Basecoat Primer
- 11 Render finish (e.g. AQUAPANEL® Exterior Mineral Finish – white)

### WM111C.1 Single stud exterior wall

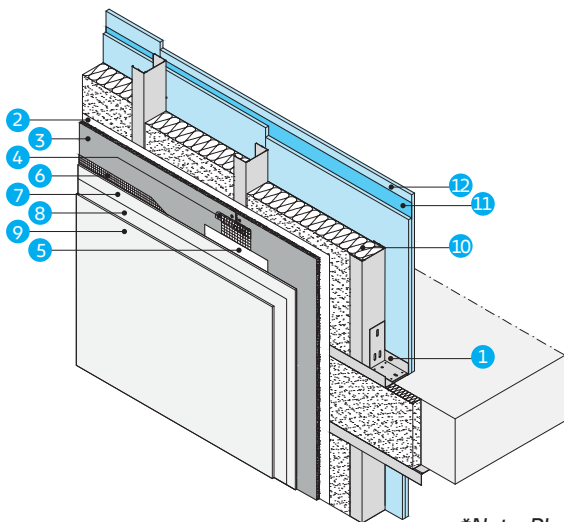

- 1 RONDO Exterior Wall System
- 2 Vapour Barrier SD  $\geq 50\text{m}$  according to the EN 13984\*
- 3 AQUAPANEL® Cement Board Outdoor
- 4 AQUAPANEL® Joint Tape (10 cm)
- 5 AQUAPANEL® Joint Filler – grey
- 6 AQUAPANEL® Reinforcing Mesh
- 7 AQUAPANEL® Exterior Basecoat
- 8 AQUAPANEL® Basecoat Primer
- 9 Render finish (e.g. AQUAPANEL® Exterior Mineral Finish – white)
- 10 Insulation board (thickness: 100 mm) according to local needs
- 11 Vapour Barrier: Knauf Insulation LDS 10 silk or similar (SD 5–10m according to EN 13984)\*
- 12 Knauf Gypsum board

*\*Note: Please be advised that under the local climate condition the vapour barrier specifications at the exterior and interior side of the wall to prevent accumulation of moisture within the wall construction could vary. Location and type of vapour barrier to be determined by the architect and a building physics expert.*

### D 282.1 EXT. SOUTHEAST ASIA Exterior ceiling

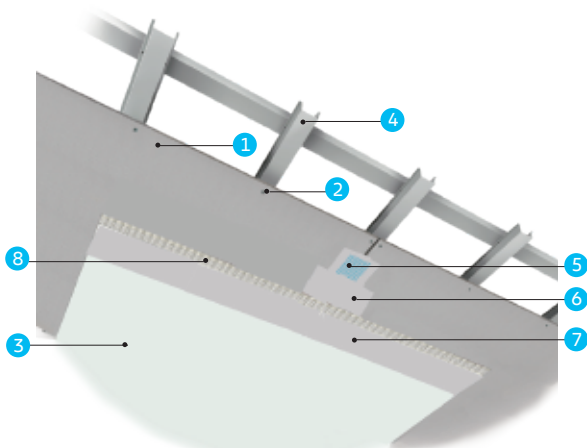

- 1 AQUAPANEL® Cement Board Outdoor
- 2 AQUAPANEL® Maxi Screws
- 3 Paint or render system by others
- 4 Rondo exterior ceiling system
- 5 AQUAPANEL® Joint Tape (10 cm)
- 6 AQUAPANEL® Joint Filler – grey
- 7 AQUAPANEL® Exterior Basecoat
- 8 AQUAPANEL® Reinforcing Mesh

# EXTERIOR PROJECTS



**Lingang Warehouse**  
*Shanghai, China*



**Markor Cave**  
*Beijing, China*



**Mercedes Showroom**  
*Ypres, Belgium*



**Starbucks**  
*Daecheon, Republic of Korea*



**Joali**  
*Maldives*



**Hunan Broadcasting System Program Production Center**  
*China*



**Knauf Sdn. Bhd**

Lot 606, Jalan Lagoon Selatan,  
47500 Subang Jaya, Selangor, Malaysia

Phone + (03) 5629 2000

[contactusmy@knauf.com](mailto:contactusmy@knauf.com)

[www.knauf.com](http://www.knauf.com)

**Knauf Singapore Pte. Ltd.**

79 Anson Road #07-01 Singapore 079906

Phone + (65) 6272 9272

[contact-us.sg@knauf.com](mailto:contact-us.sg@knauf.com)

[www.knauf.com](http://www.knauf.com)

