

# rolly<sup>®</sup> trac lader

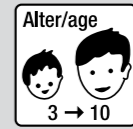

rolly toys Kundendienst Deutschland:

Tel: +49 (0) 95 68 / 856-142

Fax: +49 (0) 95 68 / 856-183

e-mail: service@rollytoys.de

2023/12

934.000.800.00

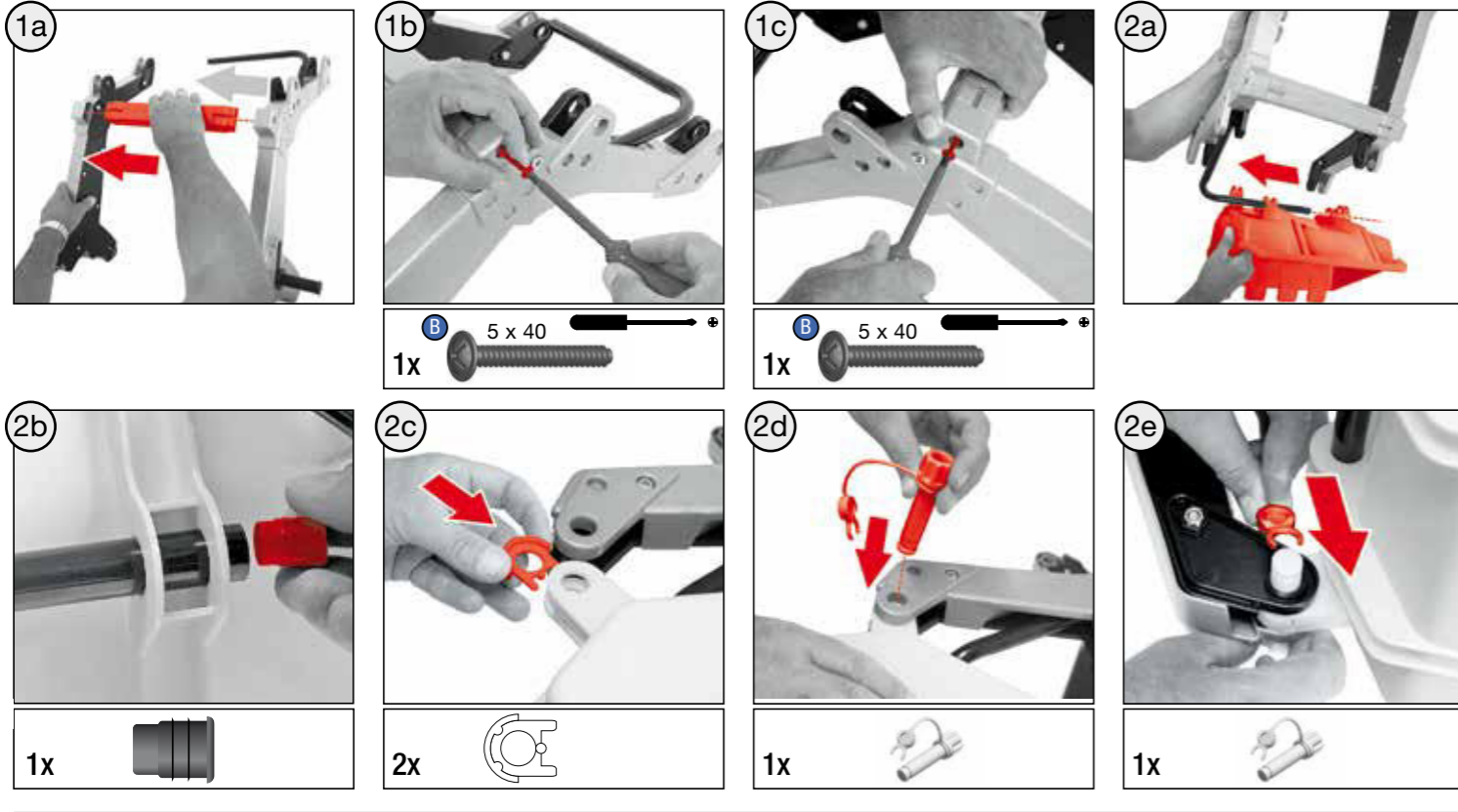

## ! WARNING

- CHOKING HAZARD - Small parts, Not for children under 3 years.
- Must be assembled by adults
- Adult supervision required.
- Toy is not suitable to carry children.
- If toy is defective stop using it, repairs may only be carried out by adults.
- Never use near steps, slopes, driveways, hills, roadways, alleys or swimming pool areas.
- Always wear shoes.
- The stickers are to be applied by adults only.
- Conforms to the requirements of ASTM Standard Consumer Safety Specification on Toy Safety, F 963.



## ! AVERTISSEMENT

- RISQUE D'ÉTOUFFEMENT - Petites pièces. Ne convient pas aux enfants de moins de 3 ans.
- Doit être assemblé par un adulte.
- Surveillance d'un adulte est requise.
- Le jouet ne convient pas au transport des enfants.
- Si le jouet est défectueux, cessez de l'utiliser. Toute réparation ne doit être effectuée que par un adulte.
- Ne jamais utiliser à proximité des marches, des pentes, des allées, des collines, des routes, des allées ou des piscines.
- Portez toujours des chaussures.
- Les autocollants ne doivent être appliqués que par des adultes.
- Conforme aux exigences de la norme internationale ASTM Standard Consumer Safety Specification on Toy Safety, F 963.

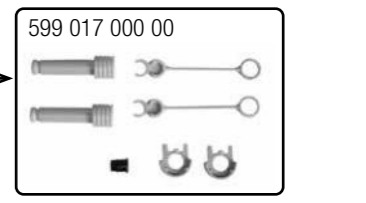
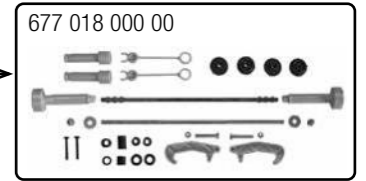
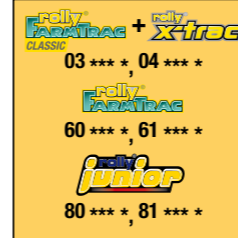
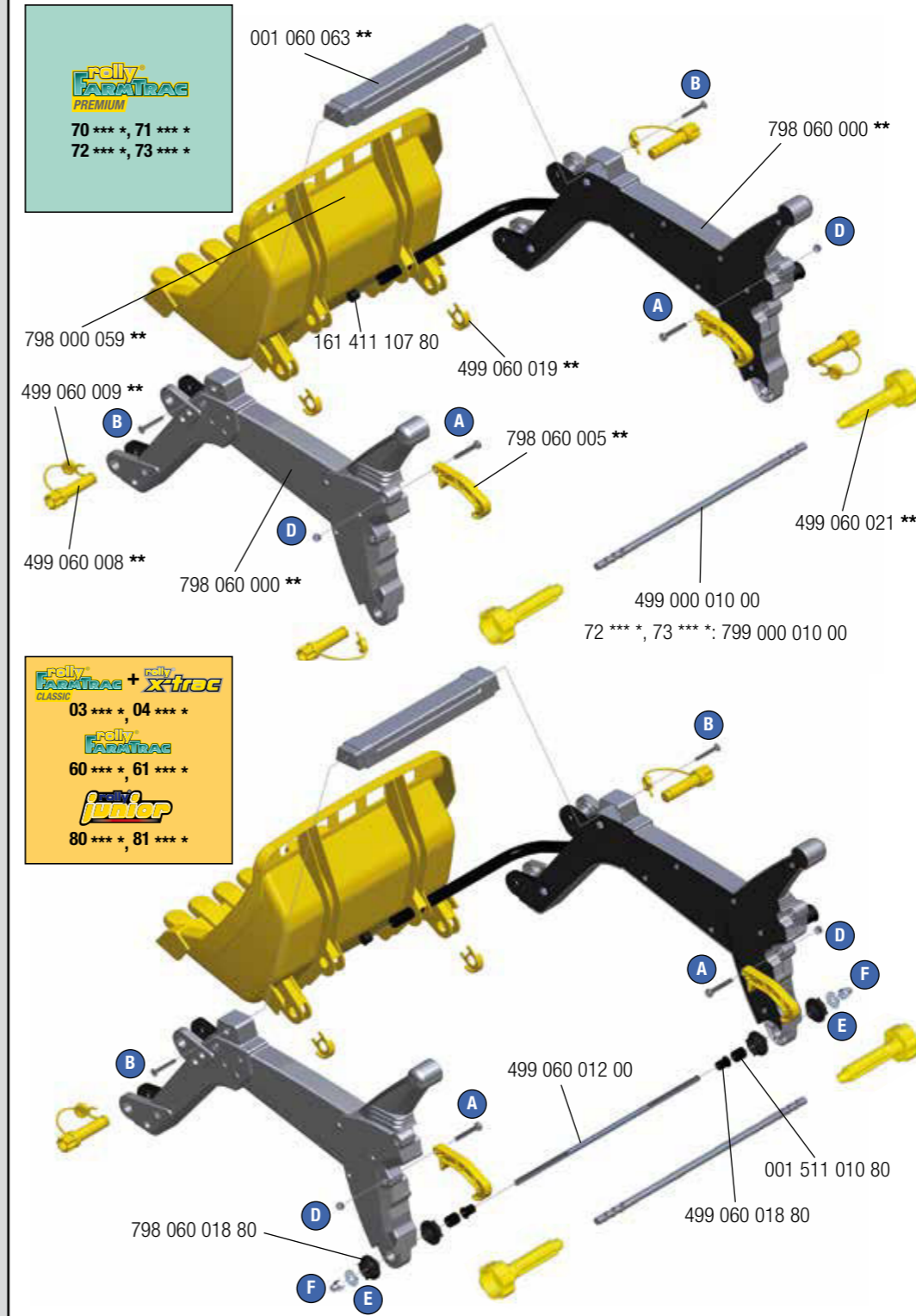

→ \*\*

● +10	● +26	● +47
● +12	● +30	● +51
● +13	● +37	● +54
● +20	● +40	● +70
● +22	● +41	● +75
● +23	● +44	● +80

--- NORTH & SOUTH AMERICA only ---  
**180 days warranty**

From the date of purchase + guaranteed spare part service  
The warranty does not cover damages caused by improper use or neglect

made in Germany



Franz Schneider GmbH & Co KG  
P.O.Box 1460  
D-96459 - Neustadt bei Coburg · Germany  
Tel.: +49 (0) 95 68 / 856-0  
Fax.: +49 (0) 95 68 / 856-190  
www.rollytoys.com

**reilly**  
**FARATRAC**  
**PREMIUM**

70 \*\*\* , 71 \*\*\* \*  
72 \*\*\* , 73 \*\*\* \*  
(A - I)

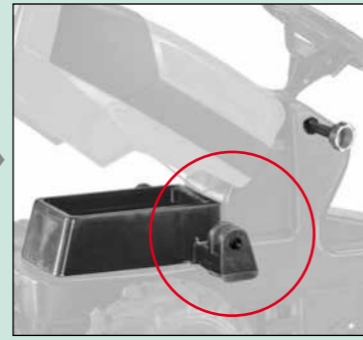
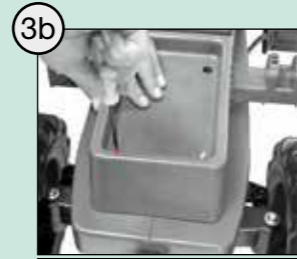
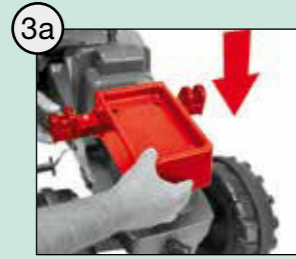

**B** 5 x 40  
2x **C** 3 x 20

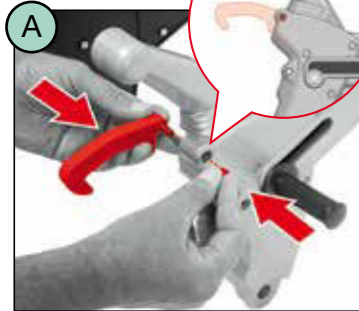

**A** M6 x 40  
1x **D** M6

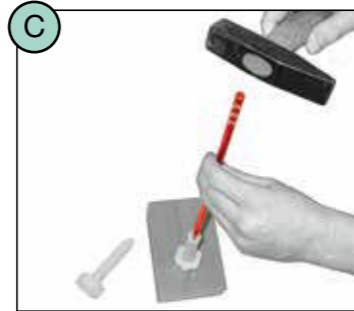
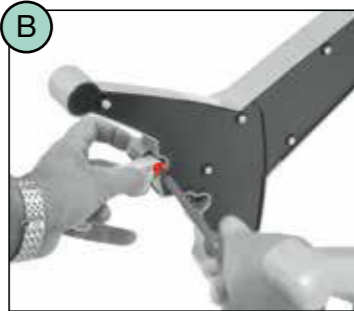

1x

70 \*\*\* , 71 \*\*\* \*:  
∅ 8 x 335mm  
72 \*\*\* , 73 \*\*\* \*:  
∅ 8 x 330mm

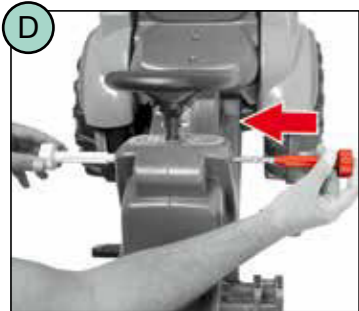

1x

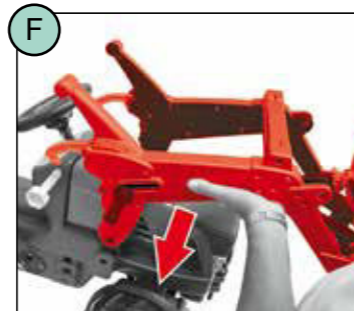
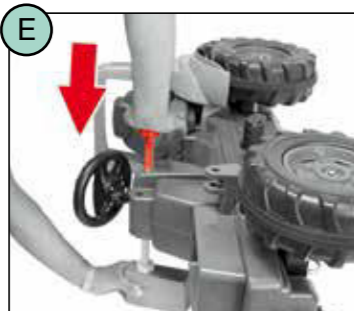

2x

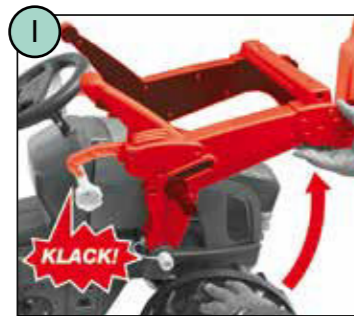
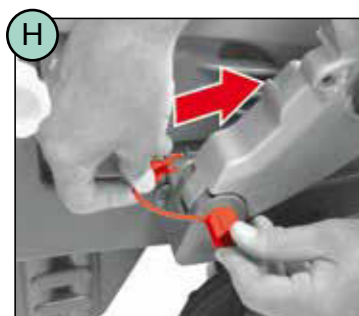

**reilly**  
**FARATRAC** + **reilly**  
**CLASSIC** **XTRAC**  
03 \*\*\* , 04 \*\*\* \*  
**reilly**  
**FARATRAC**  
60 \*\*\* , 61 \*\*\* \*  
**reilly**  
**junior**  
80 \*\*\* , 81 \*\*\* \*  
(J - Z)

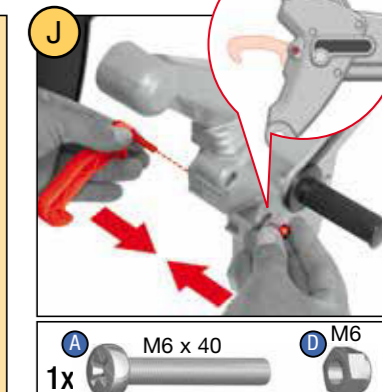
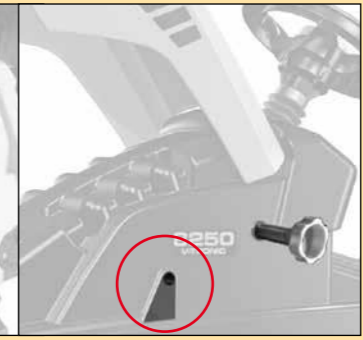
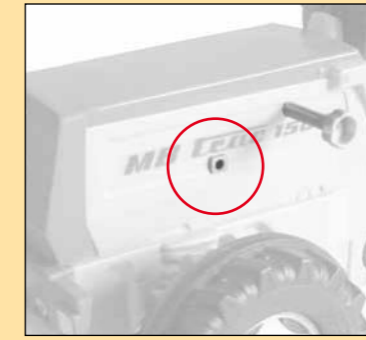

**A** M6 x 40  
1x **D** M6

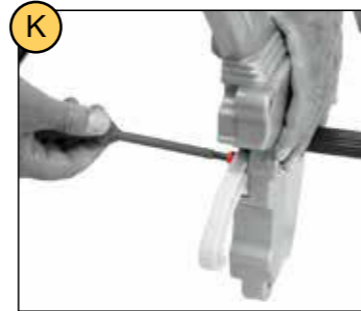

1x

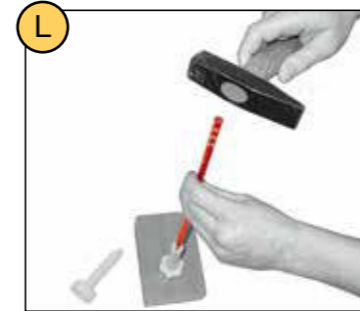

1x ∅ 8 x 335mm

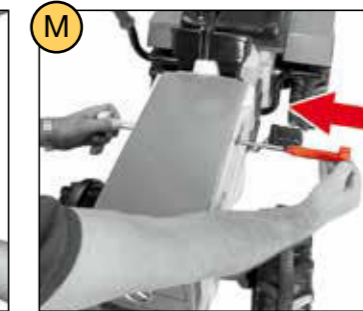

1x

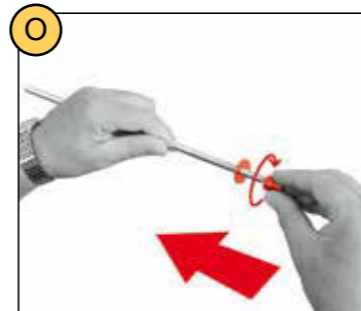
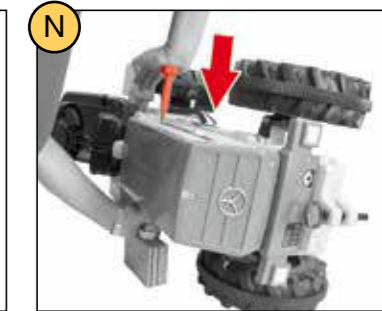

1x ∅ 8 x 345mm **E** **F**



2x ∅ 12 x 16mm

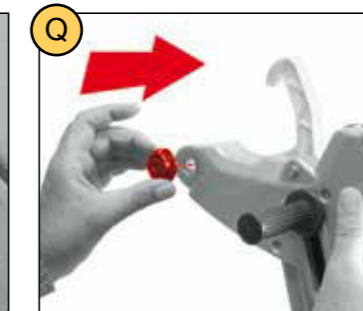

1x



1x

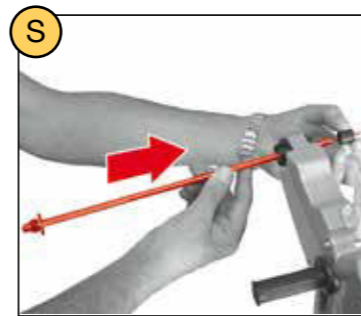

1x

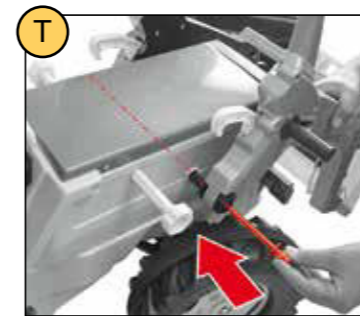

1x

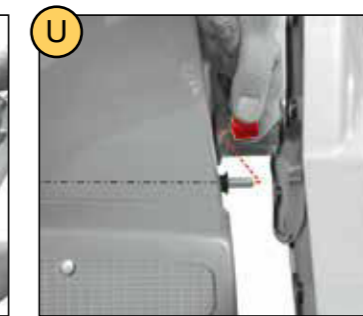

1x

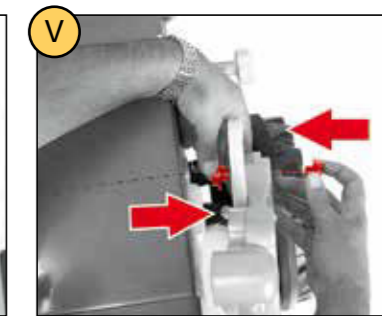

1x

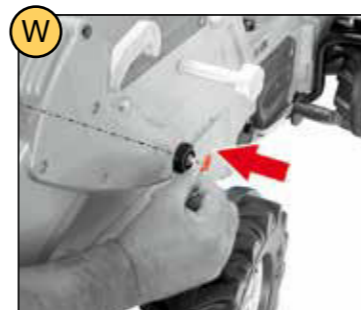

1x **E** ∅ 8,4 x ∅ 24

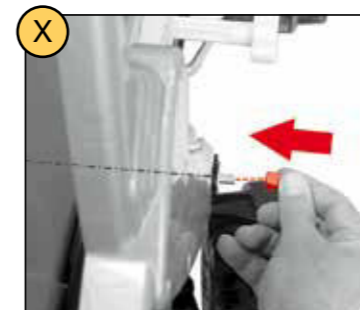

1x **F** M8

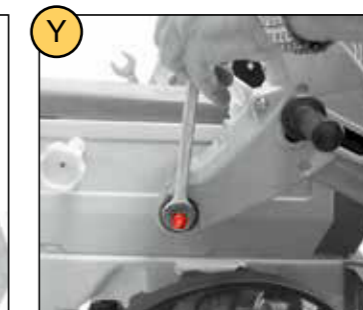

1x 13 13



**A** M6 x 40  
2x 798 506 040 00

**D** M6  
2x 098 506 000 00

**E** ∅ 8,4 x ∅ 24  
2x 902 184 000 00

**F** M8  
2x 098 608 000 00

**B** AMTEC 5 x 40  
2x 520 060 540 00

**C** ∅ 3 x 20  
2x 750 503 020 00

0 10 20 30 40 50 mm (metrisch • metric)







**rolly toys Kundendienst Deutschland:**

Tel: +49 (0) 95 68 / 856-142

Fax: +49 (0) 95 68 / 856-183

e-mail: service@rollytoys.de

**Plattform / Platform**

**72 \*\*\* \*, 73 \*\*\* \***

2022/01

**720.000.800.00**

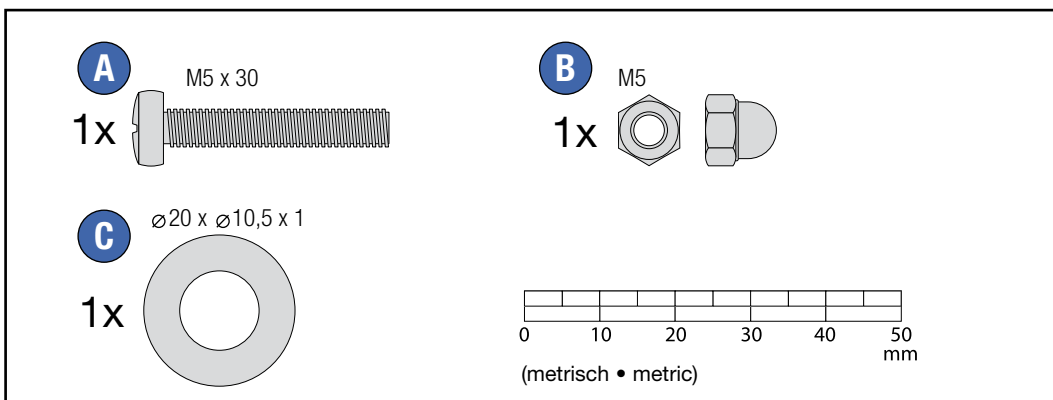
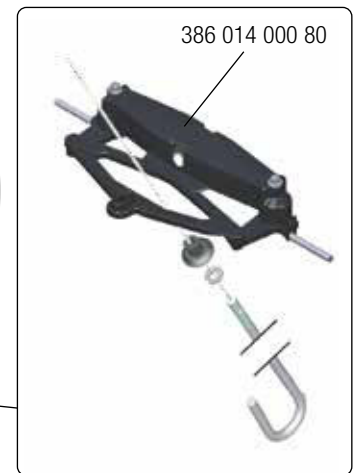
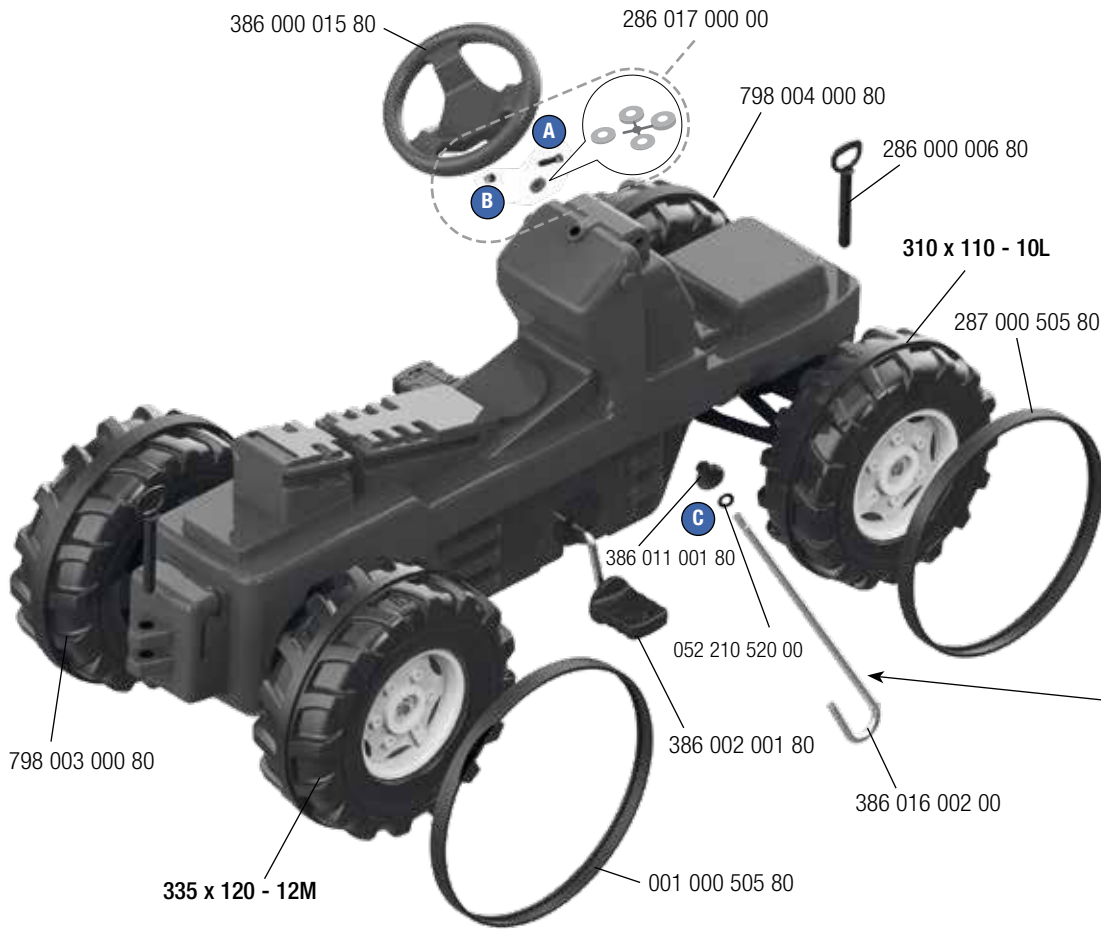

---NORTH & SOUTH AMERICA only---

**180** days warranty

From the date of purchase + guaranteed spare part service

The warranty does not cover damages caused by improper use or neglect



made in Germany

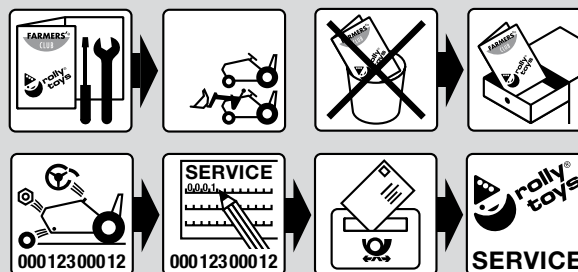

**Franz Schneider GmbH & Co KG**

P.O.Box 1460

D-96459 · Neustadt bei Coburg · Germany

Tel.: +49 (0) 95 68 / 856-0

Fax.: +49 (0) 95 68 / 856-190

www.rollytoys.com

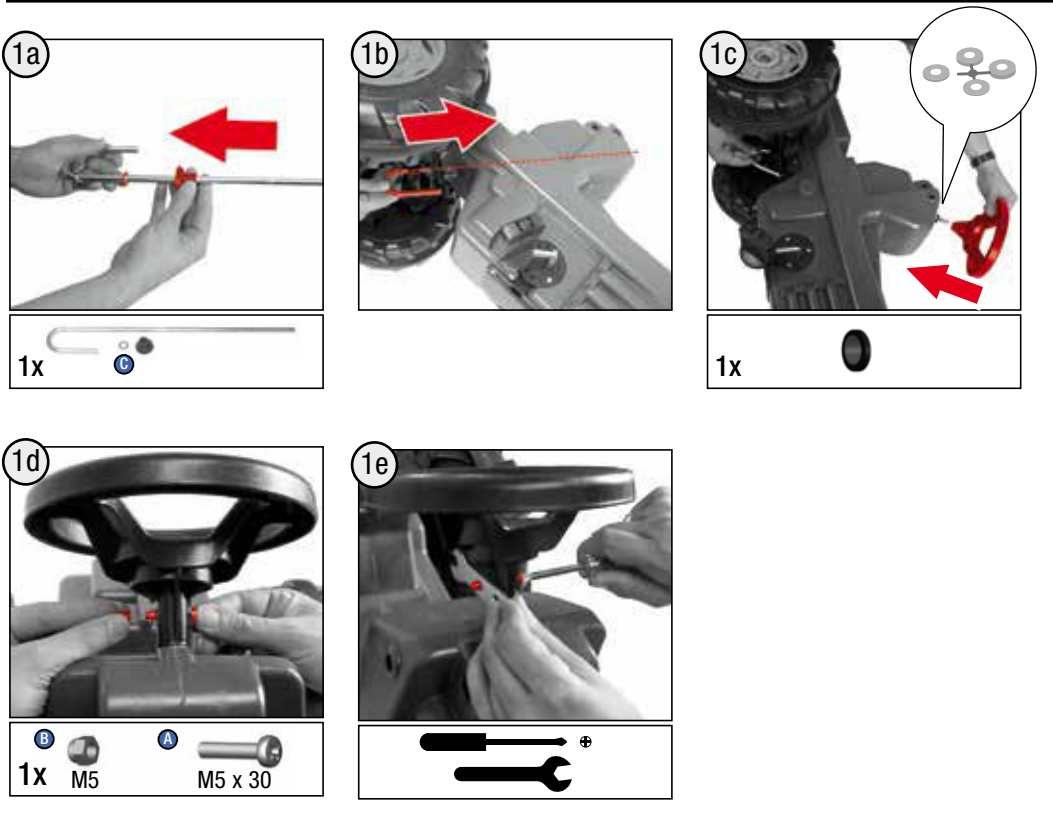

## **WARNING**

- CHOKING HAZARD - Small parts, Not for children under 3 years.
- Must be assembled by adults
- Adult supervision required.
- If toy is defective stop using it, repairs may only be carried out by adults.
- Never use near steps, slopes, driveways, hills, roadways, alleys or swimming pool areas.
- Always wear shoes.
- Never allow more than one rider.
- The use of protective gear and a safety helmet is highly recommended.
- The stickers are to be applied by adults only.
- Conforms to the requirements of ASTM Standard Consumer Safety Specification on Toy Safety, F 963.

## **AVERTISSEMENT**

- RISQUE D'ÉTOUFFEMENT - Petites pièces. Ne convient pas aux enfants de moins de 3 ans.
- Doit être assemblé par un adulte.
- Surveillance d'un adulte est requise.
- Si le jouet est défectueux, cessez de l'utiliser. Toute réparation ne doit être effectuée que par un adulte.
- Ne jamais utiliser à proximité des marches, des pentes, des allées, des collines, des routes, des allées ou des piscines.
- Portez toujours des chaussures.
- Ne permettez jamais la présence de plus d'un coureur.
- L'utilisation d'un équipement de protection et d'un casque de sécurité est fortement recommandée.
- Les autocollants ne doivent être appliqués que par des adultes.
- Conforme aux exigences de la norme internationale ASTM Standard Consumer Safety Specification on Toy Safety, F 963.

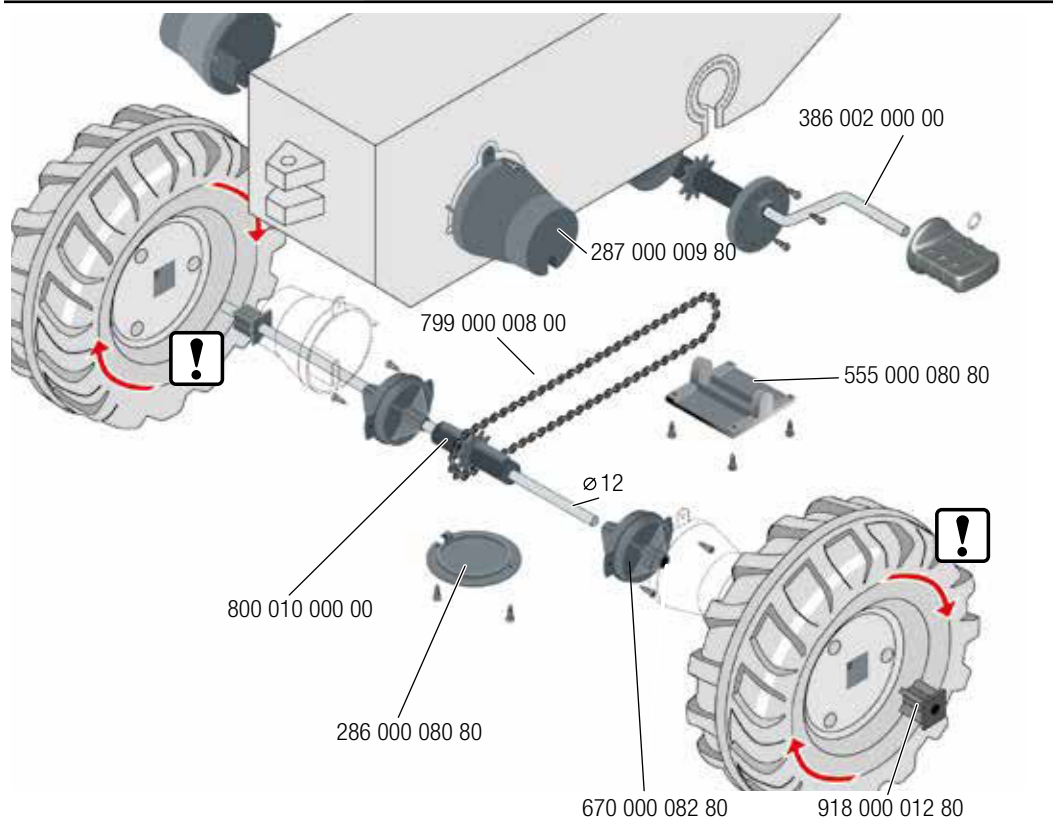



### WARNING:

**CHOKING HAZARD – Small parts.**  
Not for children under 3 years.

# STEYR

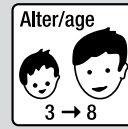

rolly toys Kundendienst Deutschland:

Tel: +49 (0) 95 68 / 856-142

Fax: +49 (0) 95 68 / 856-183

e-mail: service@rollytoys.de

**rolly FARMTRAC**  
**PREMIUM**

Plattform / Platform

72 \*\*\* \*, 73 \*\*\* \*

2022/03

**720.000.808.00**

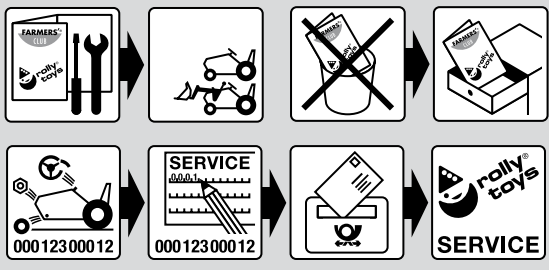
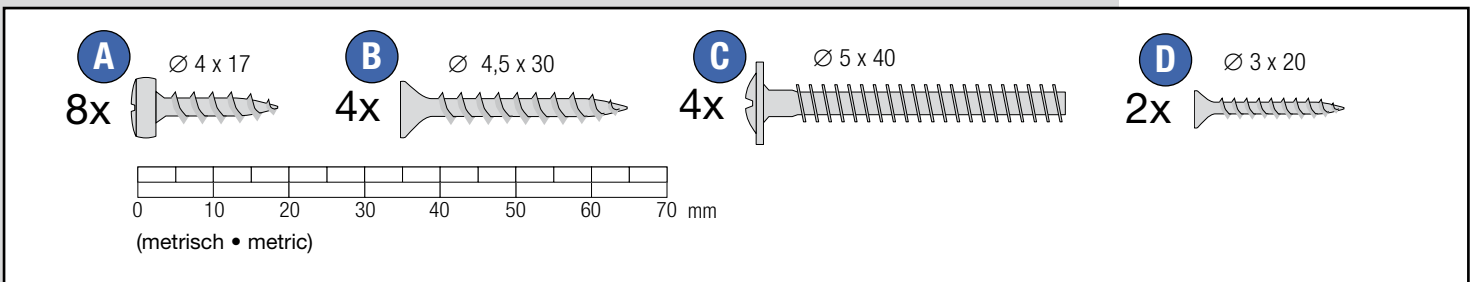
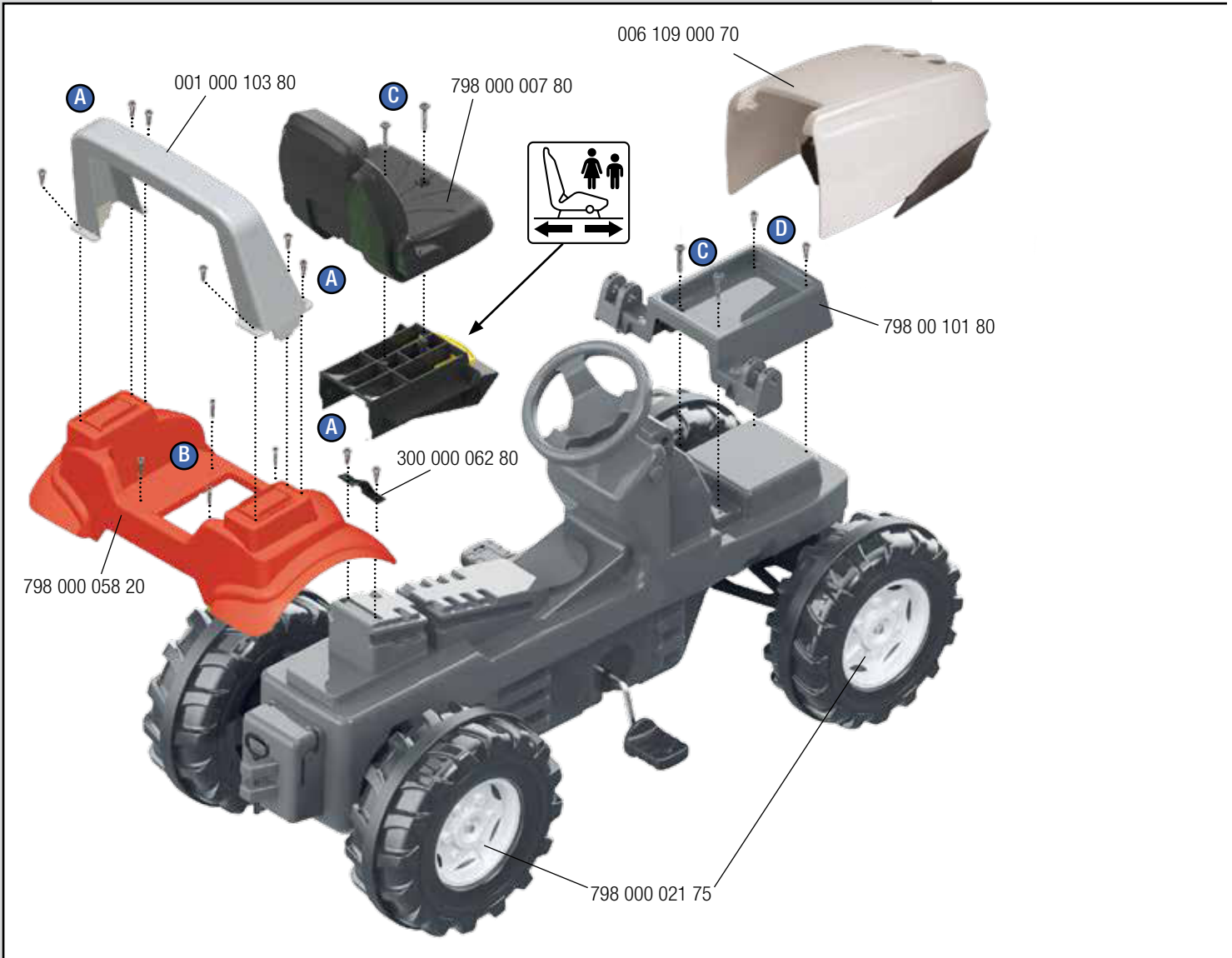



**made in Germany**



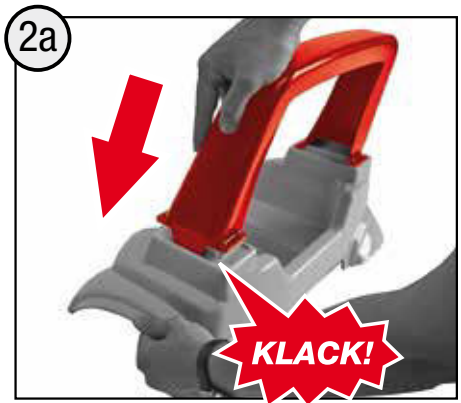
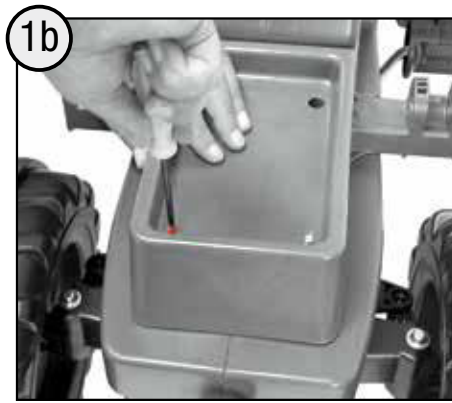
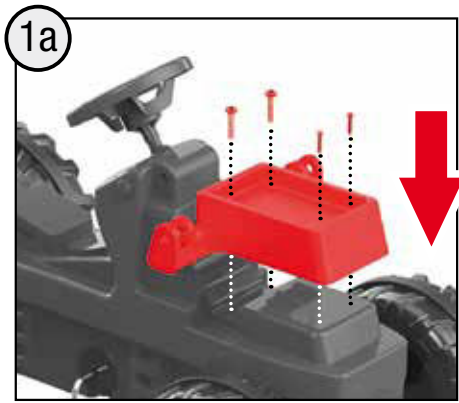

**Franz Schneider GmbH & Co KG**  
Siemensstrasse 13-19  
D-96465 · Neustadt bei Coburg · Germany  
Tel.: +49 (0) 95 68 / 856-0  
Fax.: +49 (0) 95 68 / 856-190  
www.rollytoys.com

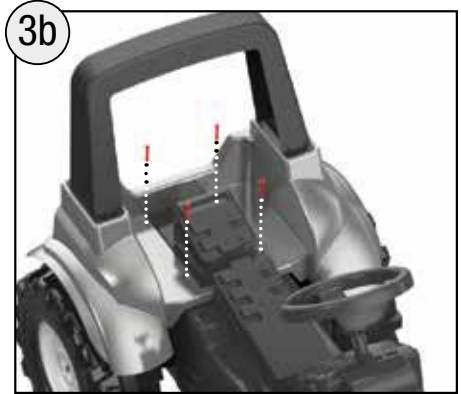
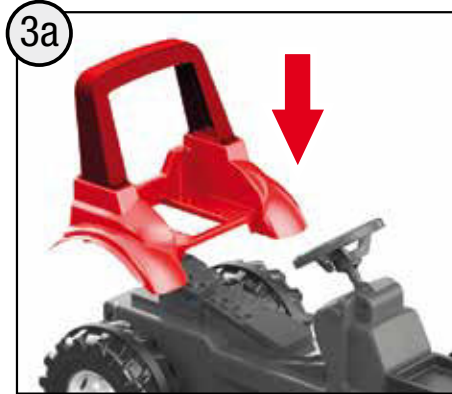
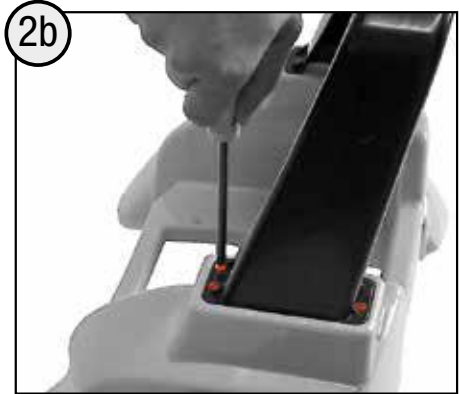

**C**  2x  $\varnothing$  5 x 40     **D**  2x  $\varnothing$  3 x 20



**A**  6x  $\varnothing$  4 x 17     

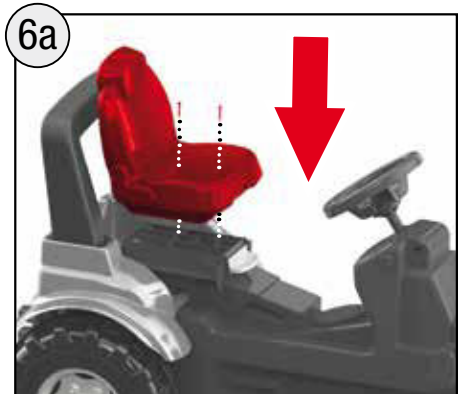
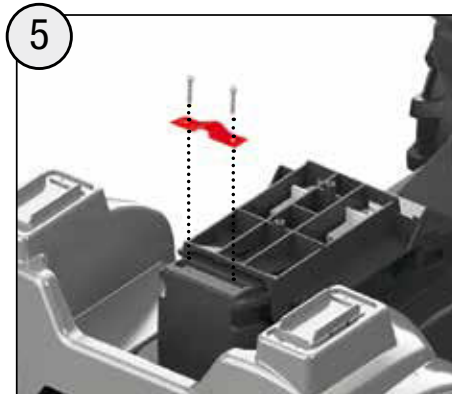
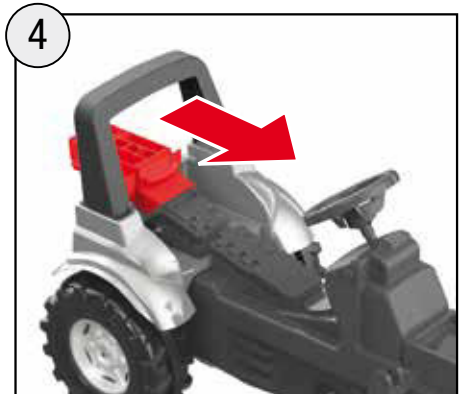

**A**  2x  $\varnothing$  4 x 17     

**C**  2x  $\varnothing$  5 x 40

