



REF. 2052L - 2056L -
2057L - 2058L - 2059L



FALK TOYS

22, rue Jean Mermoz
01100 oyonnax- France
Tel : +33 (0)4 74 77 50 46
E-mail : contact@falquet.fr

WWW.FALK-TOYS.COM



FOLLOW US !



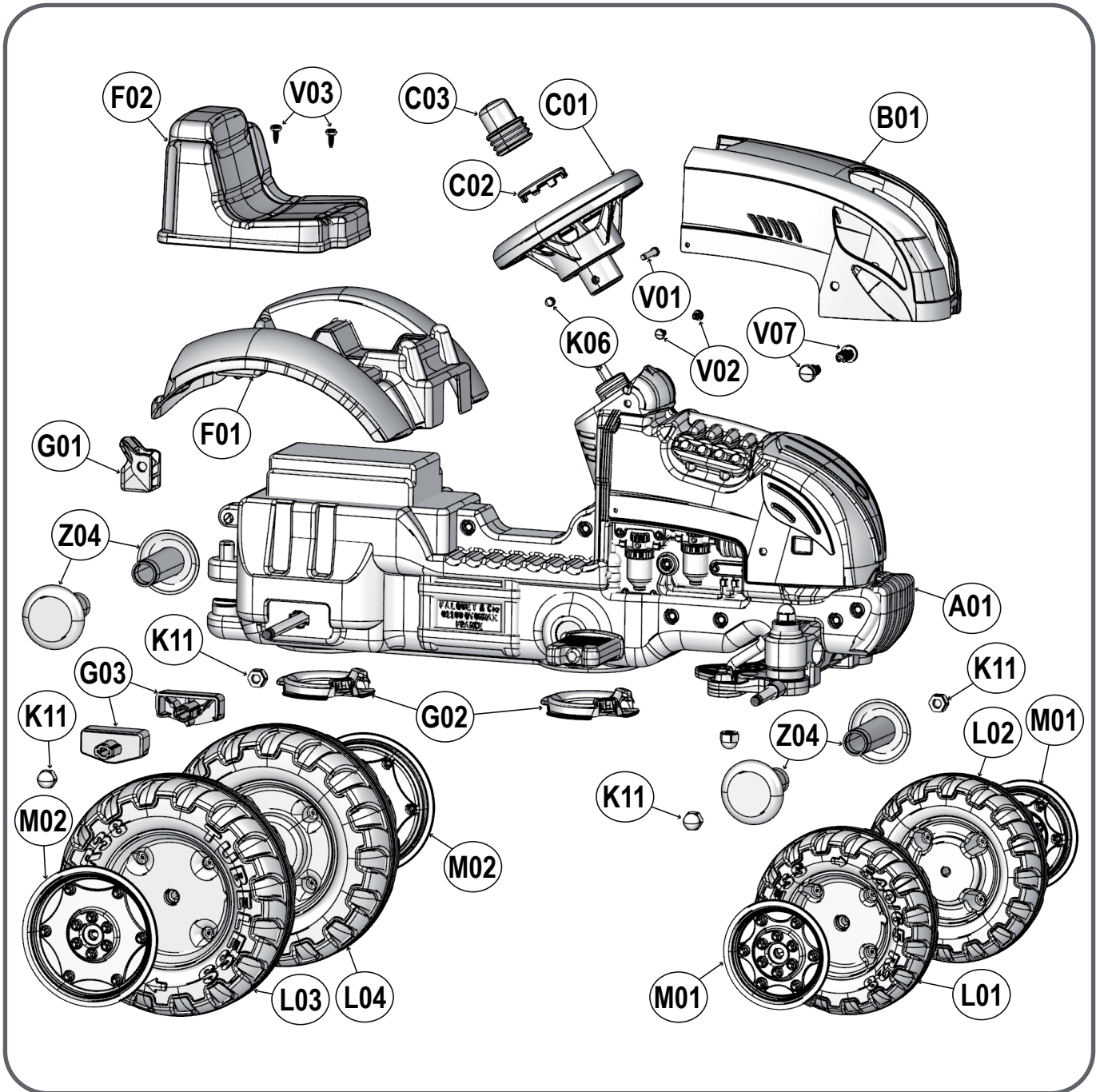

V01	K06	C01	C02	C03	K11	G01	V02	V07
M5 x 35 mm x 1	M5 x 1	x 1	x 1	x 1	M10 x 4	x 1	Ø3 x 16 x 2	x 2

Z05	Z04
x 2	x 2

Outils non fournis - Tools not provided
Werkzeuge nicht geliefert



1

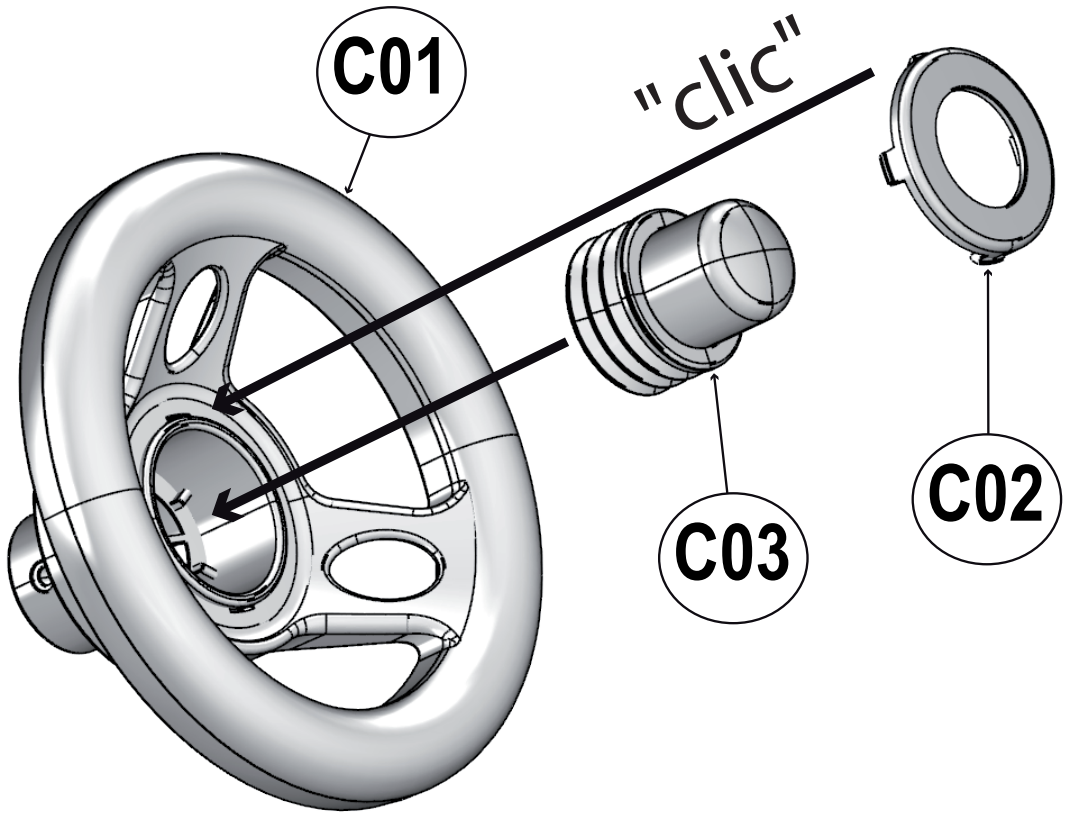

2

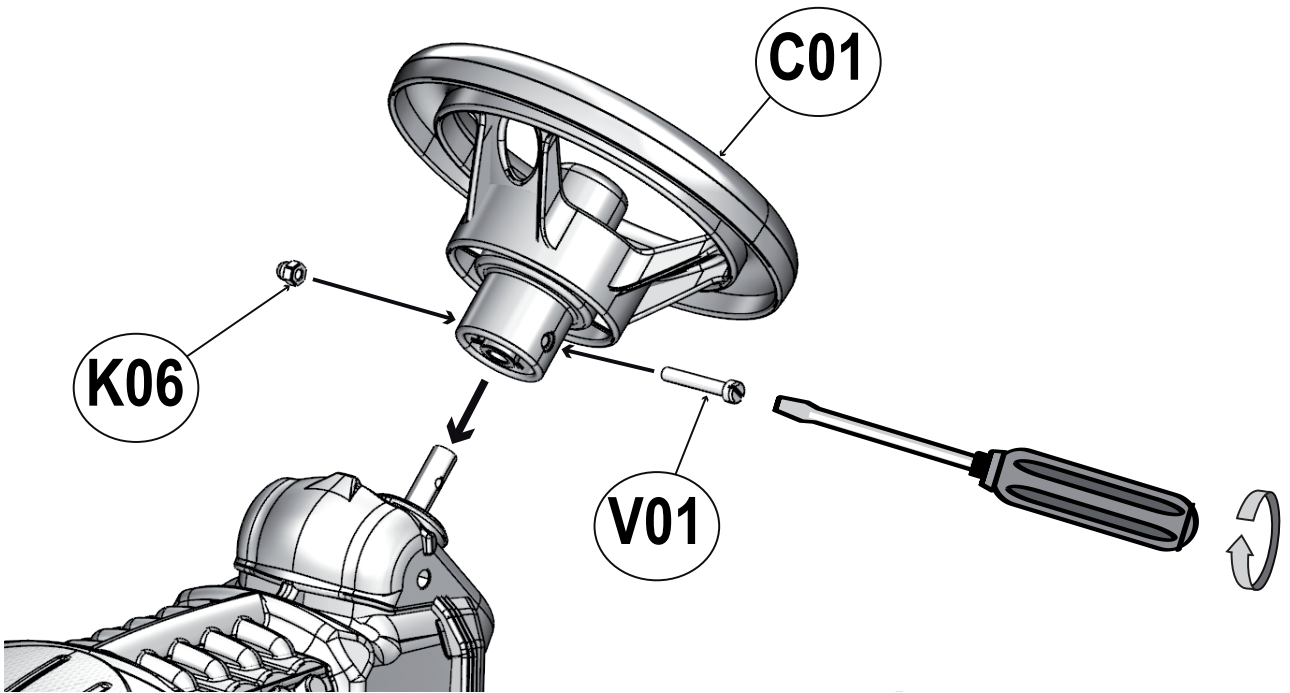

3

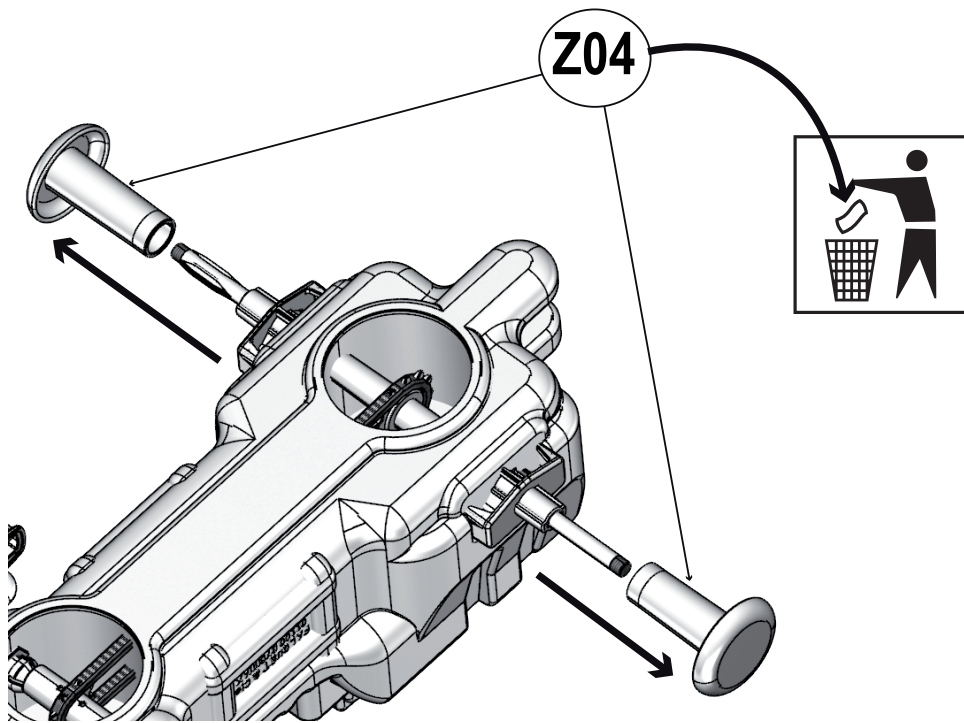

4

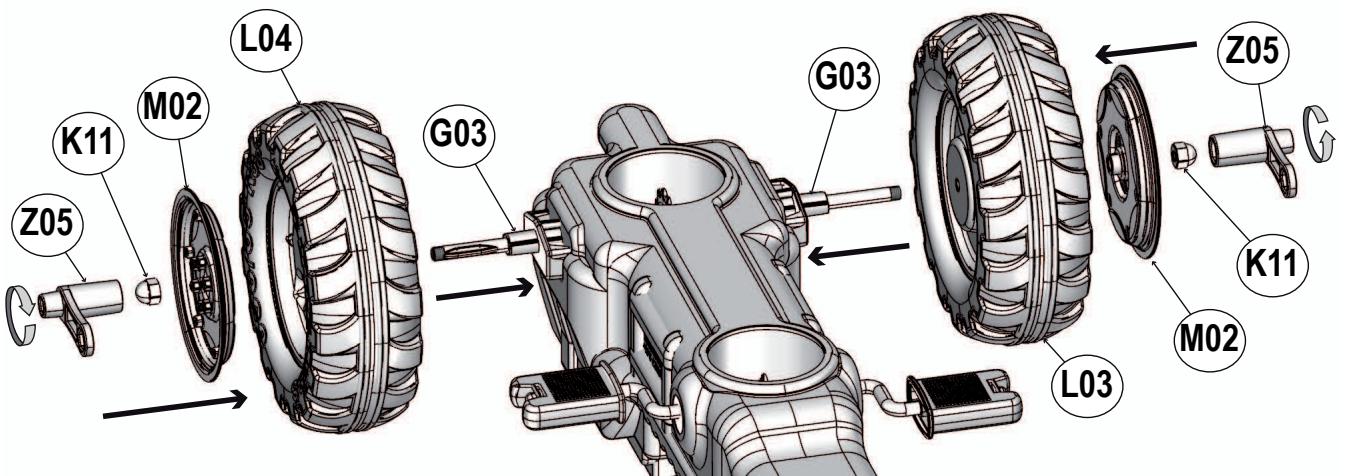

5

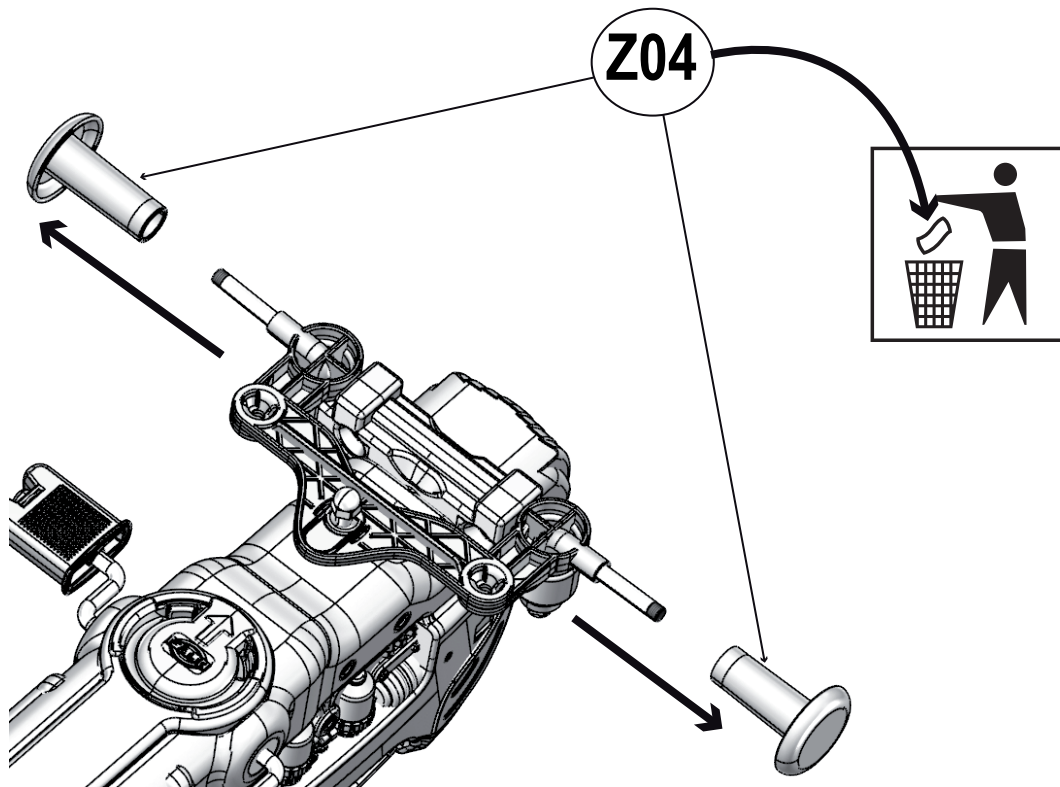

6

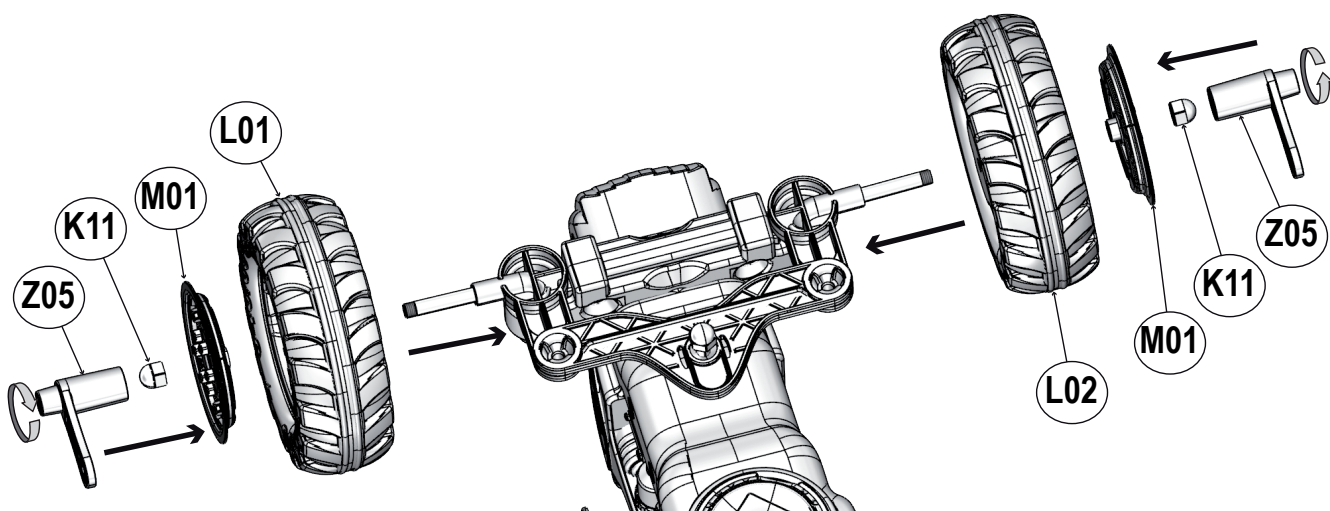

7

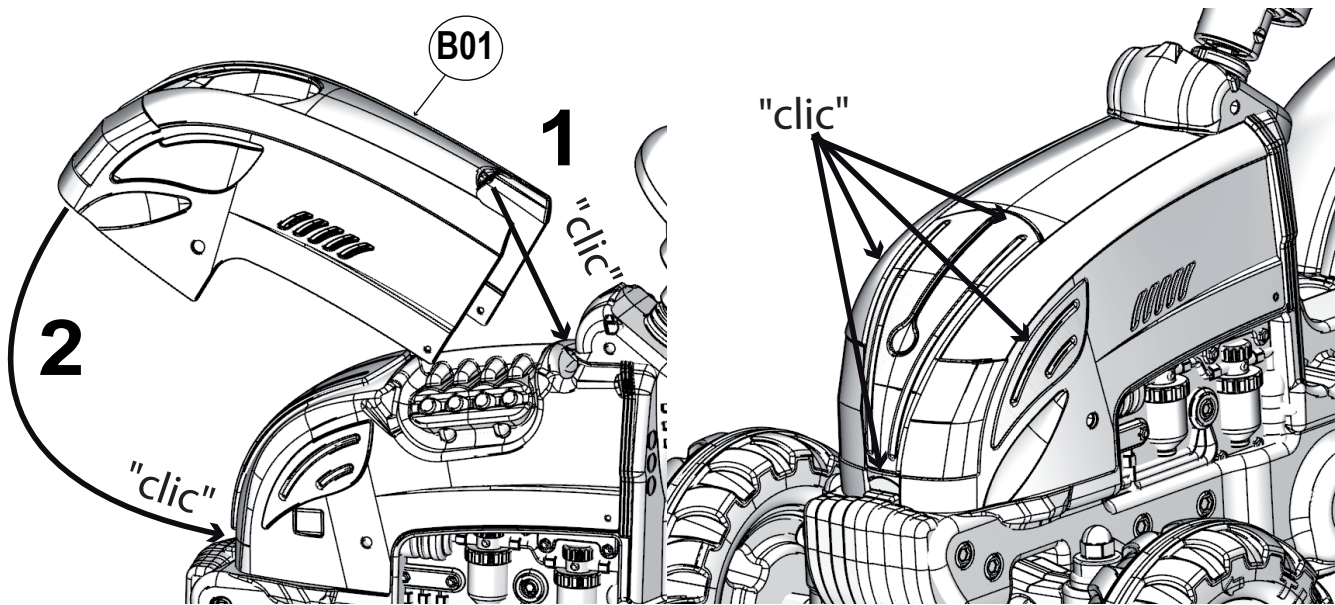

8

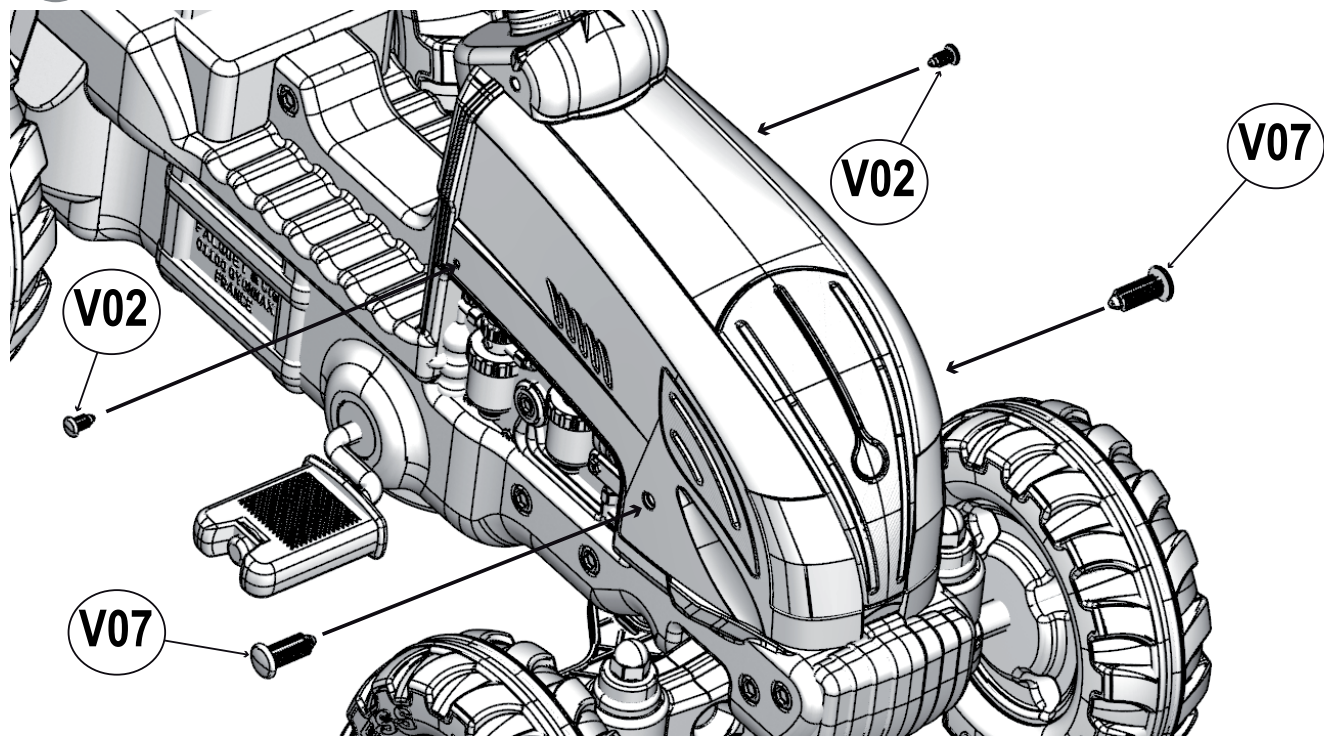

7

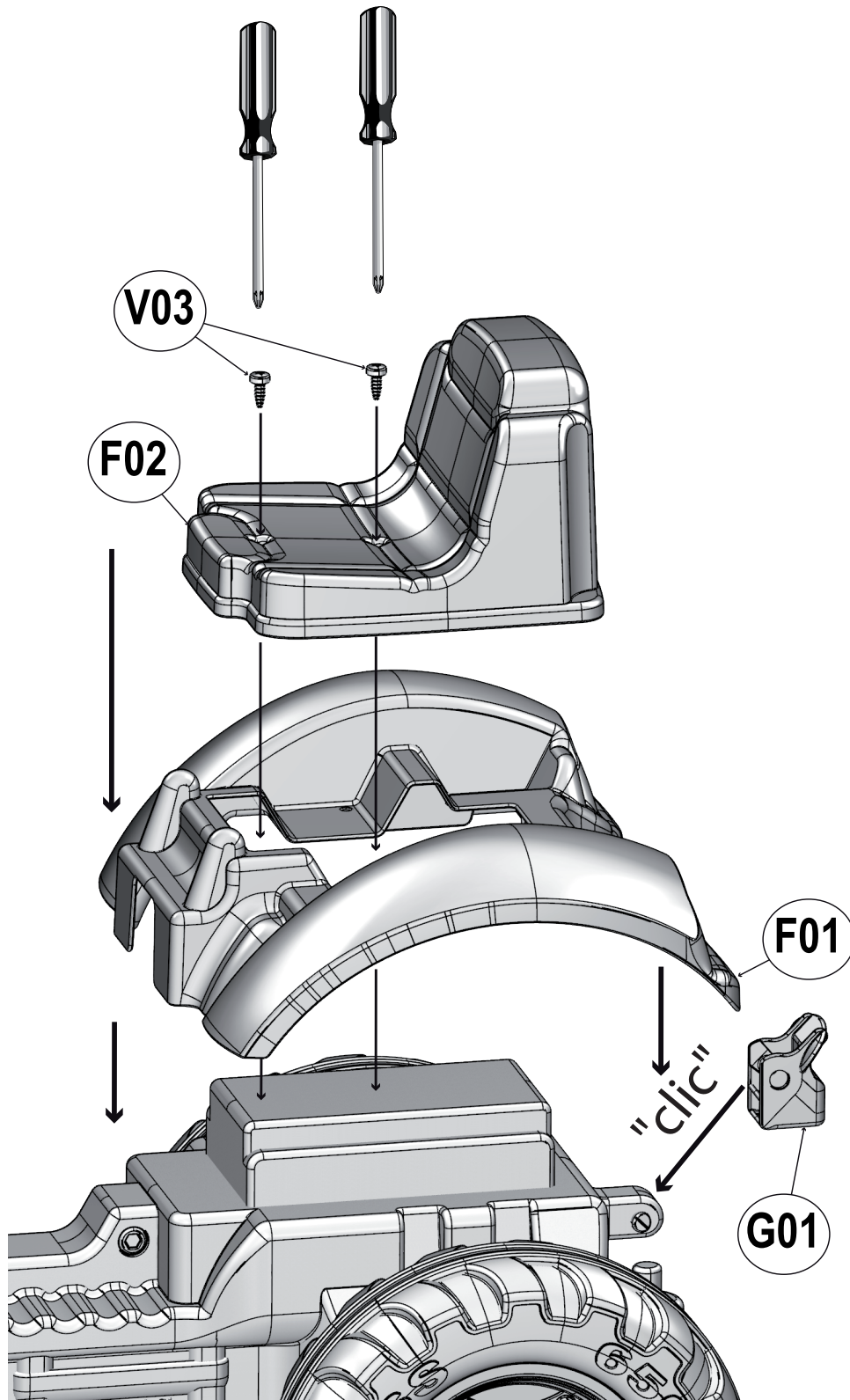

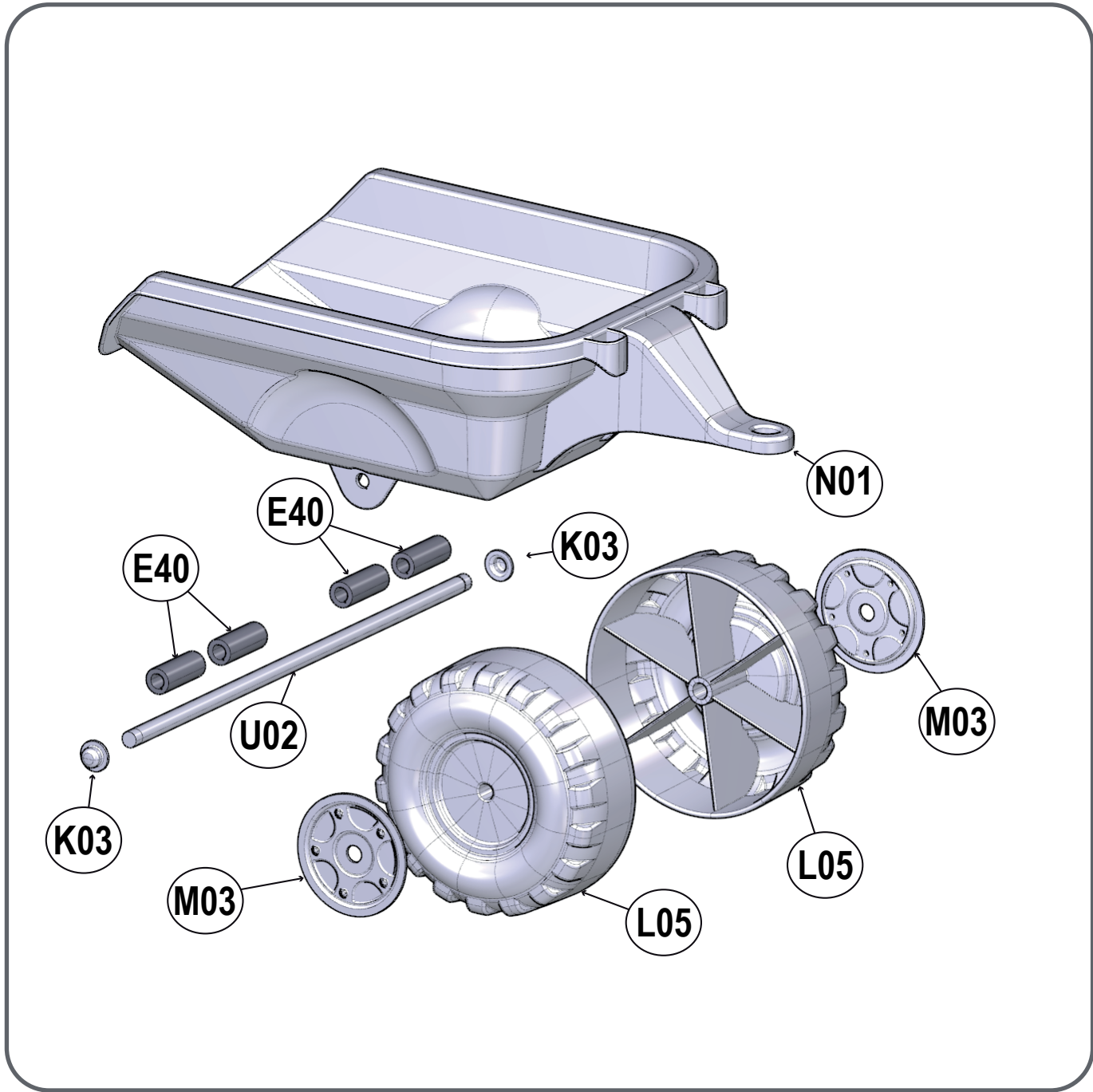

M03	L05	Z01	Z02	K03	E40
x 2	x 2	x 1	x 2	x 2	x 4

U02		x 1
Ø10 mm x 385 mm		

1

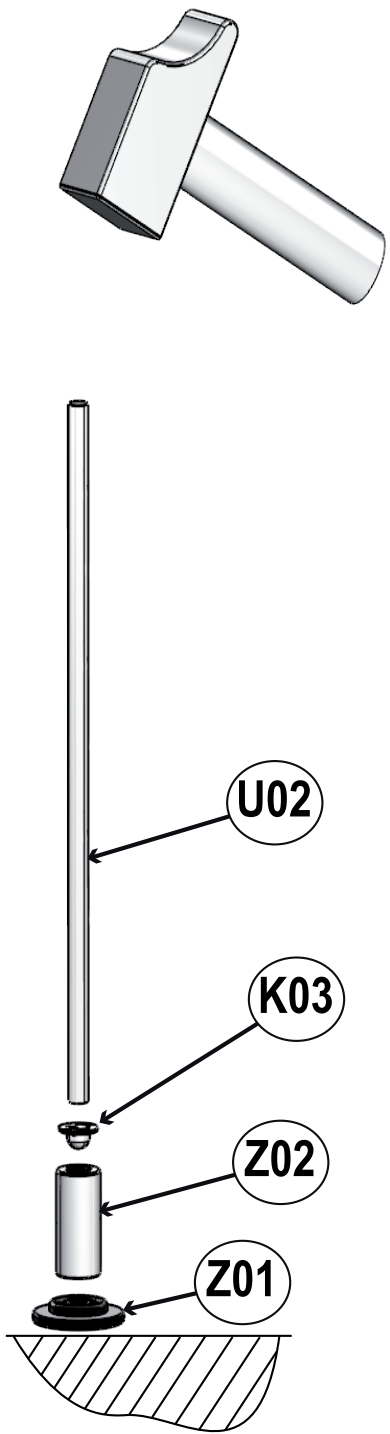

2

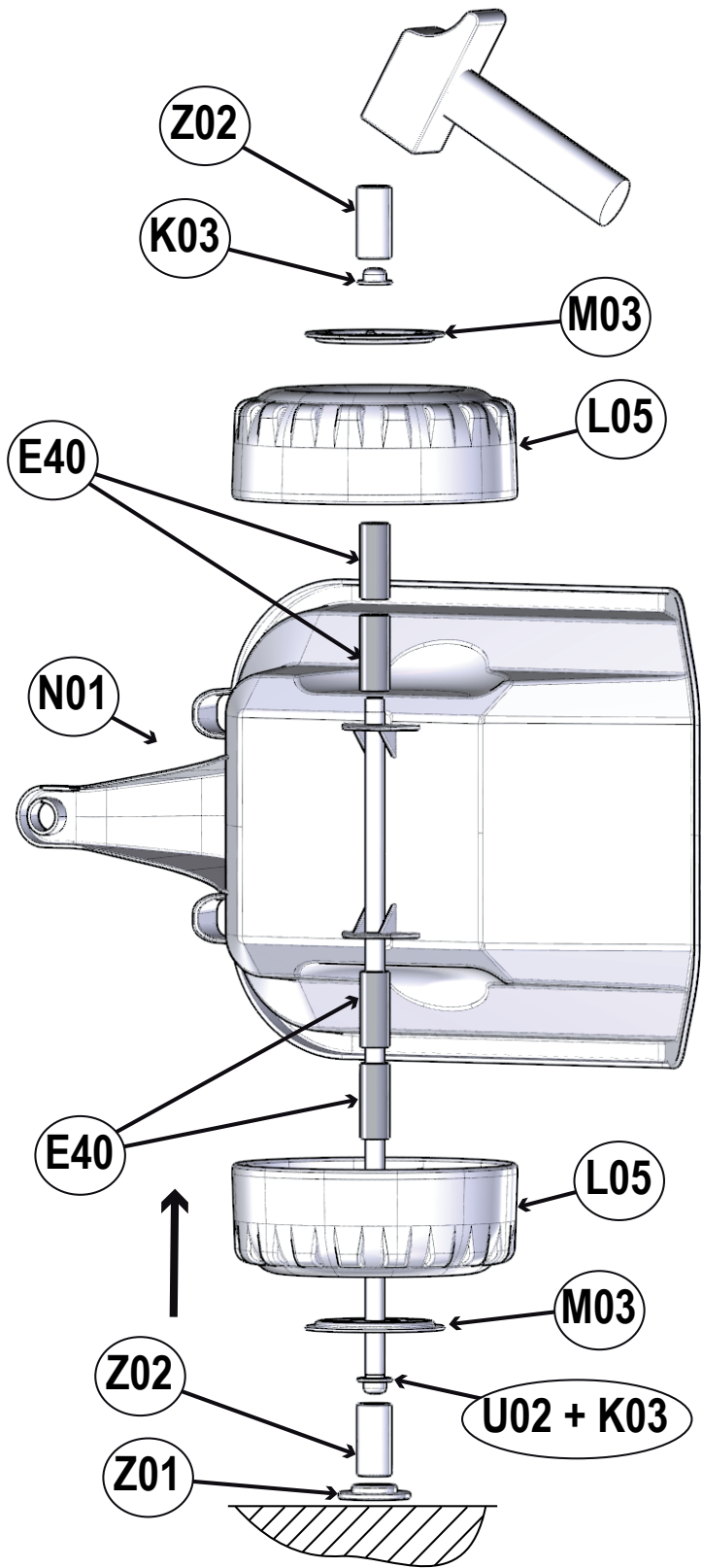

3

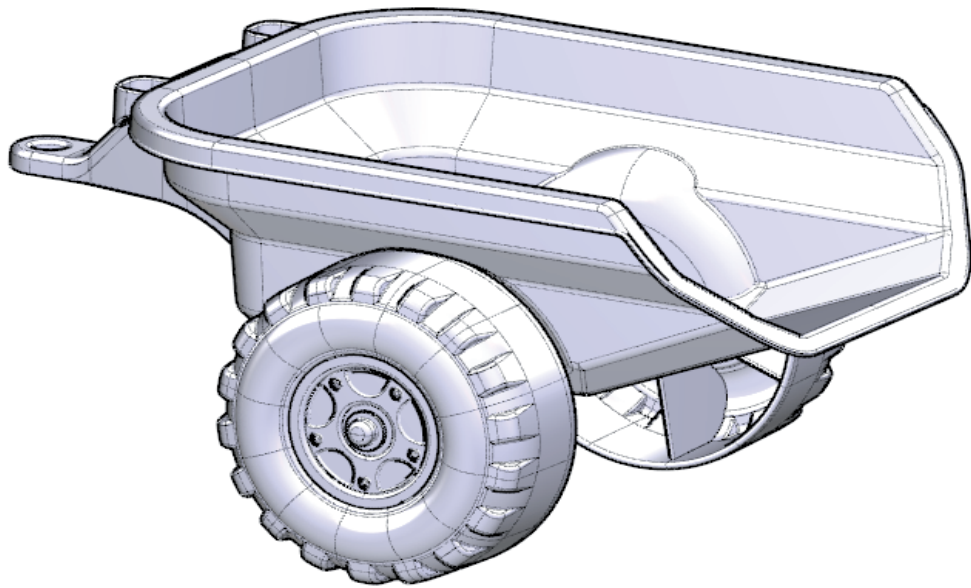



Un problème avec un de nos jouets ? Complétez ce formulaire et envoyez le nous, on s'occupe du reste !
An issue with one of our toys ? Please fill this form and send it to us, we'll do all the rest !

Par email à / By email to : sav@falquet.fr | Par fax au / By fax : (0033) 04 74 77 60 61

Date de la demande :
Request date

SAV Sous Garantie
Concerns parts still under warranty

SAV Hors Garantie
Concerns parts out of warranty

Qui êtes-vous ?

Who are you ?

Nom Prénom / Full Name :

Adresse complete / Full Address :

Code Postal / Postal Code :

Ville / City :

Pays / Country :

Société / Company :

Telephone / Phone number :

Adresse e-mail / E-Mail address :

Quel est votre jouet ?

Please describe your toy

Reference du produit / Item reference ⁽¹⁾ :

[Joindre une photo si possible / Please join a picture if possible]

Date d'achat / Date of purchase ⁽²⁾ :

N° de lot / Batch number ⁽³⁾ :

Quel est le problème ? ⁽⁵⁾

Tell us what's wrong

Oups ! Il manque une pièce / Oops ! A part is missing ⁽⁴⁾

Tracteur / Tractor

Remorque / Trailer

Autre / Other

Aïe ! Il y a eu de la casse pendant le transport

Ouch ! Parts have been damaged during transport

Pièces usées par des centaines d'heures de jeux

Worn out parts due to long hours of play

Autres / Other

[Préciser / To clarify]

1. Référence Falk uniquement (voir packaging).
Falk reference only (printed on the packaging).
2. Joindre une preuve d'achat.
Please add proof of purchase.
3. Le N° de lot se trouve sur une étiquette blanche avec QR Code collée sur l'emballage.
Batch N° is on a white sticker with a QR Code on the packaging.
4. Dans le cas d'un combiné tracteur + remorque, merci de préciser si la lou les pièces manquantes concernent le tracteur ou la remorque.
If your product is a tractor + trailer set, thanks in advance for letting us know wether this request concerns the tractor or the trailer.
5. Pour les pièces détachées hors garantie, un devis est établi et envoyé au client par e-mail pour accord. Aucune commande de produit hors garantie ne sera envoyée avant réception du paiement
For all demand concerning out of warranty parts, a quotation will be sent out to your attention for approval. Shipment will then be done after payment has been received.

Plus d'informations utiles à nous donner ? Cela facilitera le traitement de votre demande ! ⁽⁵⁾

Any additional information could help to handle your case.